

VOLUME 3

“RETAIL SUPPLY MANAGEMENT”

SUMMARY OF VOLUME 3 CHANGES

Hyperlinks are denoted by ***bold, italic, blue and underlined font.***

The original publication date of this Marine Corps Order (right header) will not change unless/until a full revision of the MCO has been conducted.

The date denoted by ***blue font*** (left header) will reflect the date this Volume was last updated.

All Volume changes denoted in ***blue font*** will reset to black font upon a full revision of this Volume.

VOLUME VERSION	SUMMARY OF CHANGE	ORIGINATION DATE	DATE OF CHANGES
ORIGINAL VOLUME	N/A	DD MMM YYYY	N/A

Submit recommended changes to this Volume, via the proper channels, to:

CMC (LPC-2)
 3000 Marine Corps Pentagon
 Washington, DC 20350-3000

VOLUME 3: RETAIL SUPPLY MANAGEMENT

TABLE OF CONTENTS

REFERENCES	REF-1
CHAPTER 1: GENERAL OVERVIEW	1-2
0101 GENERAL	1-2
0102 ROLES AND RESPONSIBILITIES	1-2
0103 ADMINISTRATION AND LOGISTICS	1-5
0104 LEGAL FOUNDATION	1-6
0105 COMPONENTS OF SUPPLY MATERIEL MANAGEMENT	1-6
0106 INVENTORY LEVELS OF SUPPLY	1-7
0107 RETAIL-LEVEL SUPPLY ACTIVITY	1-8
0108 CONFLICTS OF INTEREST	1-10
0109 APPOINTMENT/RELIEF OF COMMANDING OFFICER SUPPLY OFFICER/ACCOUNTABLE PROPERTY OFFICER, AND RESPONSIBLE OFFER	1-10
0110 DELEGATION OF AUTHORITY AND SUCCESSION TO COMMAND	1-12
0111 TYPES OF MATERIAL	1-14
0112 DIRECTIVES AND PUBLICATIONS	1-16
0113 PROCEDURES AND FOLDERS	1-17
0114 RECORDS INSPECTION	1-18
0115 POLICY WAIVERS	1-19
0116 TRAINING	1-19
0117 INTERNAL CONTROLS AND AUDIT READINESS	1-19
FIGURE 1-1: INVENTORY LEVELS OF SUPPLY	1-7
CHAPTER 2: INVENTORY MANAGEMENT AND CONTROL	2-1
0201 GENERAL	2-2

0202 ALLOWANCE ITEM INFORMATION	2-2
0203 ACQUISITION OBJECTIVE	2-6
0204 APPROVED ACQUISITION OBJECTIVE (AAO)	2-6
0205 ALLOWANCE ITEMS	2-6
0206 ALLOWANCE ITEM MANAGEMENT	2-15
0207 COMMAND ADJUSTMENT MANAGEMENT	2-18
0208 REMAIN BEHIND EQUIPMENT	2-20
0209 SMALL ARMS/LIGHT WEAPONS (SA/LW) CONTROL	2-20
0210 RETENTION OF RECORDS	2-21
0211 UNSERVICEABLE ASSETS	2-22
0212 EXCESSES	2-23
0213 DEMAND-SUPPORTED ITEMS	2-23
0214 SL-3 COMPONENTS LIST	2-25
0215 GARRISON PERSONAL PROPERTY	2-28
0216 GARRISON TOOL ALLOWANCES	2-29
0217 ELECTRONIC KEY MANAGEMENT SYSTEM EQUIPMENT	2-29
0218 SERIALIZED ITEMS	2-29
CHAPTER 3: WAREHOUSING	3-1
0301 RETAIL WAREHOUSING	3-2
0302 RETAIL STORAGE PROCEDURES	3-2
0303 RETAIL STORAGE LAYOUT	3-7
0304 SAFETY	3-11
0305 FIELD WAREHOUSING	3-15
FIGURE 3-1: TYPICAL ROADSIDE STORAGE LAYOUT	3-17
FIGURE 3-2: TYPICAL DEPTH-STORAGE DUMP	3-18

CHAPTER 4: MISCELLANEOUS ACCOUNTING	4-1
0401 GENERAL	4-2
0402 RETENTION OF RECORDS AND SECURE STORAGE FOR CASH COLLECTION	4-2
0403 SENSITIVE OR CONTROLLED BLANK FORMS ACCOUNTABILITY	4-2
0404 PERSONAL EFFECTS AND BAGGAGE	4-3
0405 PACKAGED OPERATIONAL RATIONS	4-3
0406 ACCOUNTING FOR CLASSIFIED MATERIEL	4-3
0407 ACCOUNTING FOR MEDICAL AND DENTAL SUPPLIES AND EQUIPMENT	4-3
0408 TEMPORARY LOANS OF ORGANIC EQUIPMENT	4-3
0409 HERITAGE ASSESTS AND DISPLAY EQUIPMENT	4-5
0410 FLAGS OR CLOTHING ISSUED FOR BURIAL OF NAVY AND MARINE CORPS PERSONNEL	4-13
0411 REPAIR, REPLACEMENT, AND DISPOSITION OF FLAGS AND STANDARDS	4-13
0412 GAS CYLINDERS AND VAPOR FUELS	4-14
0413 RADIOLOGICAL AND HAZARDOUS ITEMS	4-14
0414 TRANSFER OF PROPERTY TO FOREIGN GOVERNMENTS	4-14
0415 SALES OF GOVERNMENT PROPERTY	4-14
0416 SALES OF INDIVIDUAL EQUIPMENT TO INDIVIDUAL MARINES	4-18
0417 PROPERTY ISSUED FOR USE OF THE GUARD	4-18
0418 PAINTINGS	4-19
0419 THE OFFICAL MARINE CORPS SEAL AND EMBLEM	4-20
0420 PERSONAL RETENTION ITEMS	4-21
0421 GENERAL OFFICER’S STATIONERY ITEMS	4-22
0422 ORGANIZATIONAL CLOTHING AND EQUIPMENT	4-22
0423 ANIMALS	4-24

0424 LOAN OF PROPERTY TO NON-GOVERNMENT ORGANIZATIONS (NGOS)	4-24
0425 MATERIAL WITHOUT TABLE OF ORGANIZATION & EQUIPMENT ALLOWANCES 4-25	
0426 INITIAL ISSUE PROVISIONING (IIP)	4-25
FIGURE 4-1: MATERIEL WITHOUT TO&E ALLOWANCES	4-25

VOLUME 3: RETAIL SUPPLY MANAGEMENT

TABLE OF CONTENTS

APPENDICES

A	SUPPLY OFFICER / ACCOUNTABLE PROPERTY OFFICER APPOINTMENT LETTER FORMAT	1
B	RESPONSIBLE OFFICER / PROPERTY CUSTODIAN APPOINTMENT LETTER FORMAT	1
C	FUND HOLDER APPOINTMENT LETTER FORMAT	1
D	GCPC APPROVING OFFICIAL APPOINTMENT LETTER FORMAT	1
E	GCPC CARDHOLDER APPOINTMENT LETTER FORMAT.....	1
F	CERTIFYING OFFICER APPOINTMENT LETTER FORMAT	1
G	COMMANDING OFFICER CERTIFICATE OF RELIEF FORMAT	1
H	SUPPLY OFFICER/ACCOUNTABLE PROPERTY OFFICER CERTIFICATE OF RELIEF FORMAT	1
I	CLASSES AND SUBCLASSES OF SUPPLY	1
J	TABLE OF AUTHORIZED MATERIEL CONTROL NUMBERS.....	1
K	REQUEST FOR HERITAGE ASSET DETERMINATION FORMAT	1
L	REQUEST FOR CONDITIONAL LOAN OR DISPLAY EQUIPMENT RETENTION FORMAT	1
M	COMPARTMENT MARKINGS	1
N	STORAGE CONTAINERS	1
O	SHELF LIFE CODES	1
P	SUPPLY CONDITION CODES.....	1
Q	TEMPLATE FOR UPDATING TACTICAL NON-STANDARD EQUIPMENT AND SPECIAL ITEM EQUIPMENT REQUIREMENTS	1

REFERENCES

- (a) MCO 7301R.65
- (b) MCO 4400.79
- (c) SECNAV M-5210.1
- (d) DoD Manual 4140.01 “DoD Supply Chain Materiel Management Procedures,”
February 10, 2014
- (e) DoD 7000.14-R, “Department of Defense Financial Management Regulations”
- (f) Marine Corps Manual (MARCORMAN), 1980
- (g) MCO 4410.28
- (h) DoD Instruction 4160.28, “DoD Demilitarization (DEMIL) Program,” April 7, 2011
- (i) MCO 5000.14D
- (j) NAVMC 3500.64B, “Supply Administration and Operations Training and Readiness Manual,”
February 10, 2014
- (k) MCO 5200.24D
- (l) NAVMC 4000.5A, “Supply Officer’s Internal Controls Handbook”
- (m) DoD 4100.39-M, “Federal Logistics Information (FLIS) System Procedures Manual”
- (n) MCO 4410.29
- (o) MCO 5311.1E
- (p) MCO P11240.106B
- (q) MCO 3900.17
- (r) MCO 3900.15B
- (s) MCO 3000.11E
- (t) MCO 3502.6A
- (u) MCO 3000.13
- (v) DoD Instruction 1225.06, “Equipping the Reserve Forces,” May 16, 2012
- (w) DoD Instruction 5000.64, “Accountability and Management of DoD Equipment and Other
Accountable Property,” May 19, 2011
- (x) MCO 5530.14A
- (y) MCO 8300.1D
- (z) Joint Publication 1-02, “Department of Defense Dictionary of Military and Associated Terms,”
November 8, 2010
- (aa) MCO 4400.39
- (ab) OPNAVINST 5210.20
- (ac) National Archives and Records Administrations General Records Schedule 6, April 2010
- (ad) MCO P4400.82F
- (ae) MCO 4790.2
- (af) SECNAVINST 7320.10A
- (ag) MCO 2281.1A
- (ah) MCO 4410.27A
- (ai) SECNAVINST 4440.34
- (aj) DoD 4140.27-M, “Shelf-Life Item Management Manual,” May 5, 2003
- (ak) DLM 4000.25-2, “Military Standard Transaction Reporting and Accountability Procedures
(MILSTRAP),” June 13, 2012
- (al) MIL-STD-129R, “Military Standard Marking for Shipment and Storage,” February 18, 2014
- (am) MCO 4450.15A

- (an) DLM 4000.25-1, "Military Standard Requisitioning and Issue Procedures (MILSTRIP)," June 13, 2012
- (ao) Defense Transportation Regulation 4500.9-R-Part II, "Cargo Movement," May 2014
- (ap) NAVSEA OP 5 Volume 1, "Ammunition And Explosives Safety Ashore"
- (aq) NAVSEA OP 5 Volume 3, "Ammunition and Explosives Safety Ashore for Contingencies, Combat Operations, Military Operations other than War, and Associated Training"
- (ar) NAVSEA SW020-AF-HBK-010, "Motor Vehicle Driver and Shipping Inspector's Manual for Ammunition, Explosives and Related Hazardous Materials"
- (as) MCO P4030.21D
- (at) MCO 5100.29B
- (au) MCO P5102.1B
- (av) MCO 11000.11
- (aw) MCO 5100.19F
- (ax) DoD Instruction 6055.1, "DoD Safety and Occupational Health (SOH) Program," October 14, 2014
- (ay) MCO 4450.12A
- (az) MCO 10330.2D
- (ba) DoD Instruction 6050.05, "DoD Hazard Communication (HAZCOM) Program," August 15, 2006
- (bb) MCO 5104.3B
- (bc) Marine Corps Stock List SL-8-09993A, "Special List for Blank Forms and Miscellaneous Printed Items," April 1, 2008
- (bd) MCO 5600.31A
- (be) MCO 10110.14M
- (bf) MCO 10110.47A
- (bg) SECNAV M-5510.36
- (bh) NAVMC 4000.3, "Marine Corps Medical Information Systems Handbook," September 15, 2011
- (bi) MCO 7300.21B
- (bj) MCO 5750.1H
- (bk) MCO 3040.4
- (bl) NAVMEDCOMINST 5360.1
- (bm) MCO 1533.6E
- (bn) MCO P1020.34G
- (bo) MCO P1700.27B
- (bp) MCO 5100.8
- (bq) OPNAVINST 5585.2C
- (br) MCO 5585.6
- (bs) DoDM 4160.21, "Defense Materiel Disposition Manual," October 22, 2015

VOLUME 3: CHAPTER 1

“GENERAL OVERVIEW”

SUMMARY OF SUBSTANTIVE CHANGES

All changes are denoted by **blue font** unless a full revision has been conducted.

Substantive revisions are denoted by a * symbol preceding the section, paragraph, table, or figure that includes the revision.

Hyperlinks are denoted by ***bold, italic, blue and underlined font***.

Base date of this Marine Corps Order (MCO) Volume (right header) will not change unless a full revision has been conducted. Upon full revision of this Volume, all changes denoted by blue font will reset to black font.

PAGE PARAGRAPH	EXPLANATION OF SUBSTANTIVE CHANGES	PURPOSE	DATE OF CHANGE

CHAPTER 1

GENERAL OVERVIEW

0101 GENERAL

This Volume establishes supply policy for use in the effective control of Marine Corps resources, such as ground equipment, materiel, and services, processed through Marine Corps retail-level supply organizations as well as accountability and storage of military equipment when maintained by non-retail level commands (e.g., Remote Storage Activities). Accordingly, this Volume is applicable to both consumer-level and intermediate-level supply activities. Adherence to the provisions in this Volume shall ensure accurate accountability of property and promote more effective logistics support to the warfighter. This Volume will also ensure that Marine Corps processes and procedures are in compliance with Department of Defense (DoD) regulations for supply and financial management.

0102 ROLES AND RESPONSIBILITIES

Retail-level supply operations exist in every element of the Marine Air-Ground Task Force (MAGTF), the reserves, installations, and the supporting establishment (SE). Retail-level supply operations occur in both garrison and deployed operations. Therefore, it is critical that all personnel involved in Marine Corps ground logistics support operations comprehensively understand and adhere to the provisions of this Volume. To safeguard the effective implementation of this Volume, execution of the following responsibilities is paramount:

010201. Deputy Commandant, Installations and Logistics (DC I&L)

A. As the Marine Corps Enterprise Ground Equipment Manager (EGEM), ensure the roles and responsibilities identified in this Volume are adhered to by the appropriate stakeholders to achieve and maintain strict equipment accountability and visibility.

B. As the functional advocate for logistics information systems, ensure systems are available and effective to enable retail-level supply operations.

C. Coordinate with Commanding General, Training and Education Command (CG, TECOM) to ensure the implementation of effective training programs for the contents of this Volume.

D. As necessary, ensure Field Supply and Maintenance Analysis Office (FSMAO) Teams and Internal Controls and Audit Readiness Teams (ICART), inspect Marine Corps organizations for compliance with this Volume and provide assistance to the Marine Forces (MARFORs), Marine Expeditionary Forces (MEFs), and supporting establishments/installations.

E. In coordination with Commander, Marine Corps Systems Command (MARCORSYSCOM), ensure the provisions of this Volume support total life cycle management of programs and equipment.

010202. Deputy Commandant, Plans, Policies, & Operations (DC PP&O)

Be prepared to provide guidance on the operational impacts associated with the implementation of this Volume as it relates to current and future operations.

010203. Deputy Commandant, Combat Development and Integration (DC CD&I)

A. Coordinate efforts with DC I&L to ensure implementation of this policy in consonance with current doctrine.

B. Coordinate with Commanding General, Marine Corps Logistics Command (MARCORLOGCOM), Commander, MARCORSYSCOM, and Commanding General, Marine Corps Installations Command (MCICOM) to ensure Total Force Structure Management System (TFSMS) data reflects the most current and accurate information available to enable effective ground supply operations at the retail-level.

010204. Deputy Commandant, Programs and Resources (DC P&R)

A. In coordination with DC I&L, MARCORLOGCOM, MARCORSYSCOM, and MCICOM ensure the program objective memorandum (POM) process supports the creation of a Marine Corps Future Years Defense Plan (FYDP) which resources logistics requirements in consonance with strategic guidance and efficiently and economically supports the financial requirements of the Marine Corps supply chain.

B. Publish in reference (a), approved fund codes that organizations are authorized to use to requisition against allotted funds.

010205. Commanding General, Marine Corps Logistics Command (CG, MARCORLOGCOM)

A. As the Marine Corps enterprise ground equipment inventory manager for Stores Account Code (SAC) 3 military equipment, ensure support of policies in this directive and address emerging inventory management practices.

B. In coordination with MARCORSYSCOM and DC CD&I, establish and maintain National Stock Numbers (NSN) and Identification Numbers for items entering the Marine Corps inventory and ensure data accuracy.

C. Perform duties as the Executive Agent (EA) for the Coordinated Secondary Reparable Management process, facilitating retail supply management.

D. Perform Initial Issue Provisioning (IIP) duties as outlined in reference (b) to facilitate retail supply management.

010206. Commander, Marine Corps Systems Command (COMMARCORSSYSCOM)

- A. In coordination with DC I&L, ensure the provisions of this Volume support total life cycle management of programs and equipment.
- B. In coordination with DC CD&I, maintain and ensure the equipment information in TFSMS is current to enable effective retail-level supply operations.
- C. In coordination with MARCORLOGCOM, CD&I, and MCICOM establish and maintain Table of Authorized Materiel Control Numbers (TAMCN), NSNs, and ID Numbers for items entering the Marine Corps inventory and ensure data accuracy.
- D. Perform IIP duties as outlined in reference (b) to facilitate retail supply management.
- E. Serve as the sole procurement authority, to include executing the Planning, Programming, Budget, and Execution process for Marine Corps Class V(W) in supporting and sustaining the Marine Forces.

010207. Director, Command, Control, Communications, and Computers

- A. Ensure effective hardware, software, and network communication resources are available to enable Marine Corps supply chain operations.
- B. Provide purchase request approval when requested by MCICOM project officers or appropriate MARCORSSYSCOM program managers and the request is supported by an appropriate allowance, Universal Need Statement (UNS), or Table of Organization and Equipment Change Request (TOECR).

010208. Functional Area Sponsor / Field Supply Maintenance Analysis Offices

Develop and implement an inspection program to ensure compliance with this retail-level supply policy.

010209. Commanders, Marine Corps Forces

- A. Commanders shall ensure that this policy is made available, understood, and is used by all personnel responsible for retail-level supply.
- B. Ensure the management of retail-level inventories in accordance with this policy and supply system procedures in applicable users manuals.
- C. Develop and implement internal command policies and procedures to facilitate the execution of this policy.
- D. This Volume is policy and takes precedence over all retail-level technical publications (e.g., UM 4000-125).

- E. Perform IIP duties as outlined in reference (b).

010210. Commanding General, Marine Corps Installations Command (MCICOM)

- A. Ensure that this policy is made available, understood, and is used by all personnel responsible for retail-level supply at Marine Corps supporting establishments and installations.

- B. Ensure the management of retail-level inventories at Marine Corps supporting establishments and installations is in accordance with this policy and supply system procedures in applicable users manuals.

- C. Develop and implement internal command policies and procedures to facilitate the execution of this policy.

- D. In coordination with MARCORLOGCOM, MARCORSYSCOM, and CD&I, establish and maintain TAMCNs, NSNs, and ID Numbers for garrison property and garrison mobile equipment (GME).

- E. This Volume is policy and takes precedence over all retail-level technical publications (e.g., UM 4000-125).

010211. Commanding General, Training and Education Command (TECOM)

- A. Ensure that this policy is made available, understood, and is used by all personnel responsible for retail-level supply at Marine Corps training installations.

- B. Ensure the management of retail-level inventories at Marine Corps training installations is in accordance with this policy and supply system procedures in applicable users manuals.

- C. Develop and implement internal command policies and procedures to facilitate the execution of this policy.

- D. Ensure the establishment of effective training programs for both entry-level and sustainment training of retail-level ground supply operations.

- E. This Volume takes precedence over all retail-level technical publications (e.g., UM 4000-125).

0103 ADMINISTRATION AND LOGISTICS

010301. Recommendations concerning the contents of this Volume are invited. Submit recommendations via the appropriate chain of command to the Assistant Deputy Commandant, I&L attention Logistics Policy and Capabilities Branch (LPC). Copies of recommendations will be provided to the appropriate command of responsibility to assist in corrective action.

010302. To ensure proper maintenance, use, accessibility and preservation, regardless of format or medium, records created as a result of this Volume will be managed according to National Archives and Records Administration approved dispositions per reference (c). Records created as a result of this Volume will be retained in accordance with paragraph 0210.

0104 LEGAL FOUNDATION

As a service component, what we do and how we do it is governed by statute and is further refined by Departmental and Service regulations. See Appendix A in Volume 1 of this Order for a comprehensive summary of applicable legal information as it relates to this Volume.

0105 COMPONENTS OF SUPPLY MATERIEL MANAGEMENT

Supply materiel management consists of continuing actions related to planning, organizing, directing, coordinating, controlling and evaluating the application of resources to ensure the effective and economical support of military forces. Command advocacy and awareness are primary requirements for effective supply materiel management. Supply materiel management includes two components: property control and supply support. Some supply materiel management measures may simultaneously provide for both property control and supply support.

010501. Property Control

Property control consists of all measures taken to care and account for materiel. Property control includes the implementation of physical security controls and other internal controls, the production of reports, and the maintenance of audit trails and records that provide for the clear demonstration of good stewardship of property.

010502. Supply Support

Supply support consists of all measures taken to ensure that supplies and services, in the proper quality and quantity, are available to support mission requirements. Although the flow of supply support normally culminates with the issue of required materiel and/or services to the user, supply support must continue to satisfy the user's requirements. Functions ensuring sufficient supply support include:

- A. Computing materiel requirements.
- B. Requesting, requisitioning, procuring, receiving, warehousing, distributing, shipping, issuing, selling, and disposing of all equipment, materiel, and supplies for a Marine Corps retail-level organization.
- C. Participating in supply support projects under the cognizance of the DoD.
- D. Implementing Headquarters Marine Corps (HQMC) directives for management of the Marine Corps' retail-level inventory.

E. Executing fiscal responsibilities which consist of the proper assignment of funding on a requisition (obligation document) before processing, maintaining a positive fund balance, and identifying unfunded deficiencies as required.

F. Managing automated information systems (AIS) to control access to supply chain management systems.

G. Producing accurate data and records for supply support, analysis, and action, by using information systems for supply chain, financial and supply asset management. The term “information system” refers to the following:

1. Information System. The organized collection, processing, transmission, and dissemination of information in accordance with defined procedures, whether automated or manual. Information systems include non-financial, financial, and mixed systems.

2. Accountable Property System of Record (APSR). A government information system used to control and manage accountable property records. It is a subset of existing organizational processes related to lifecycle management of property and is integrated with the core financial systems. Examples of Marine Corps APSRs include, but are not limited to Global Combat Support System – Marine Corps (GCSS-MC) or Stock Control System for military equipment or Defense Property Accounting System (DPAS) for garrison personal property and GME.

0106 INVENTORY LEVELS OF SUPPLY

There are two major inventory levels of supply within the Marine Corps: wholesale and retail.

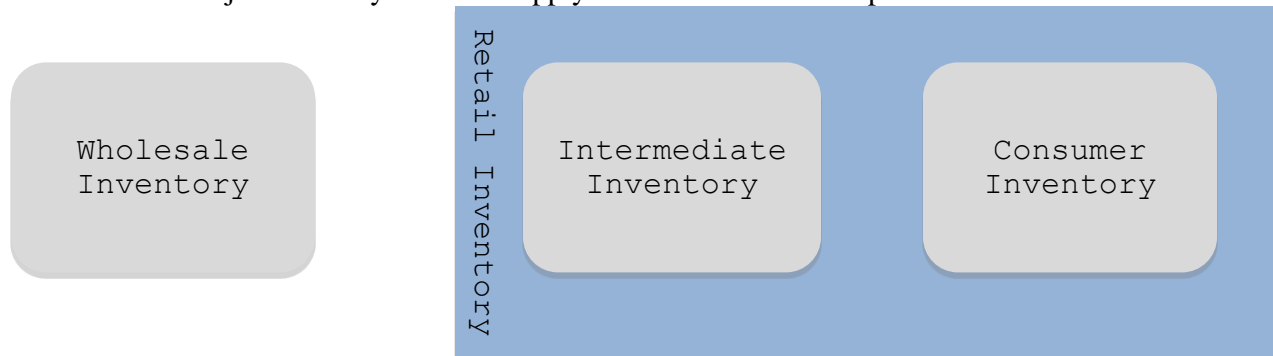

Figure 1-1. Inventory Levels of Supply

010601. Wholesale Inventory

Per reference (d), wholesale inventory includes inventory (stock), regardless of funding sources, over which the materiel manager has asset knowledge and exercises unrestricted asset control to meet worldwide inventory management responsibilities. Wholesale inventory is synonymous with national inventory. National inventories within the DoD are the Defense Logistics Agency (DLA), General Services Administration (GSA), Tank-automotive and Armaments Command, and Army Materiel Command. MARCORLOGCOM serves as the Remote Storage Activity (RSA) for Class VII equipment and applicable assemblages.

MARCORLOGCOM also supports and executes Primary Inventory Control Activity (PICA) functions for the Marine Corps.

010602. Retail Inventory

This includes supplies or materiel held below the wholesale level and consists of consumer and intermediate-level inventories.

A. Consumer-Level Inventory

Consumer-level inventory is usually of limited range and depth, held by the final element in an established supply chain distribution system for the sole purpose of internal support or use. A consumer-level inventory is independent of echelon of command and can exist at the strategic, operational, or tactical level.

B. Intermediate-Level Inventory

Intermediate-level inventory typically exists between the consumer and wholesale levels of inventory and supports a defined geographic area or provides tailored support to specific organizations or activities. Unlike the operating forces (OPFOR) accounts (i.e., Supply Management Unit (SMU), Repairable Issue Point (RIP), and Consolidated Storage Program (CSP)), Base Property Offices and Servmarts at supporting establishments manage intermediate-level inventories, but do not typically serve as an intermediary to wholesale inventory.

0107 RETAIL-LEVEL SUPPLY ACTIVITY

Before a retail-level supply activity can exist, certain requirements must be met in terms of accountability, responsibility, and assigned roles to govern, manage, and facilitate the maintenance of retail-level inventory. Volume 1, Chapter 2 of this Order provides roles and responsibilities applicable to all retail-level supply activities. The following additional guidance applies:

010701. Appointment Letters and DD 577, “Appointment/Termination Record – Authorized Signature”

Appointment letters, to include the DD 577 when required, will be signed by the Commanding Officer (CO)/Accountable Officer (AO) and will be retained for ten years (i.e., three years active and seven years archive) in accordance with paragraph 0210.

A. When appointing an individual to multiple roles (e.g., appointing the same individual as the supply officer, supply resource manager, and fiscal/budget and accounting officer), a single appointment letter and DD 577 meets the appointment requirement. In these cases, clearly identify each role in the appointment letter and DD 577. Completion of the DD 577 meets the DoD requirements in Volume 5 (Disbursing Policy) of reference (e).

B. The DD 577 does not have an appointed role in Block 13 for “supply officer” or other specific USMC roles. In these situations, use the “Departmental Accountable Official” block and identify specific roles in Block 14.

C. Appointment letter formats are in Appendices A through F in this Volume.

D. The Supply Officer / Accountable Property Officer (APO) Appointment letter (see Appendix A) and DD 577 shall not serve as a replacement to the appointment letter that is required of Approving Officials under the Government Commercial Procurement Card (GCPC) Program (see Appendix D).

E. The Supply Officer / APO Appointment letter (see Appendix A) and DD 577 shall not serve as a replacement to the appointment letter that is required of GCPC Cardholders (CH) under the GCPC Program (see Appendix E).

010702. Delegation of Authority

The supply officer will maintain copies of signed NAVMC 11869s, "Notice of Delegation of Authority." NAVMC 11869 will identify specific individuals that have been delegated authority for the following assigned duties:

A. Sign and receipt for government property and services for use within the department or section.

B. Turn in excess or damaged government property.

C. Submit purchase requests for supplies and/or services.

D. Sign and authorize the use of Urgency of Need Designator "A" (i.e., priorities 01, 02, and 03).

010703. Individual Responsibility

Individuals, who obtain and maintain public property for use in the performance of assigned duties, or come into custody of government property, are individually responsible for that property.

A. Direct Custodian

The fact that an individual has not signed a receipt for public property in that individual's possession does not relieve that individual of the required custodial, maintenance, and servicing responsibilities.

B. Financial Liability

In the case of loss, damage, or destruction of public property through causes other than wear incident to normal service, personnel responsible will either be held punitively liable, administratively held accountable (e.g., page 11 entry documenting fault or negligence), or will be excused from responsibility by competent authority.

0108 CONFLICTS OF INTEREST

The CO of retail activities shall not assign the supply officer/chief and responsible officers (ROs) duties that conflict with their supply management responsibilities.

010801. Supply personnel will not be appointed as investigating officers for any fiscal, financial liability, or supply property accountability related investigations. Additionally, ROs/property custodians will not be appointed as investigating officers for property under their charge.

010802. Supply personnel will not be appointed as ROs for any property that is internal to the command (e.g., Electronic Key Management System Equipment (EKMS) custodian). However, this should not preclude the use of APSRs to establish automated internal controls for the management of inventories held within the warehouse. Supply personnel (e.g., warehouse chief) may only be appointed as an RO for the warehouse Consolidated Memorandum Receipt (CMR)/Custodian Asset Report (CAR).

010803. Supply personnel shall only manage official appropriated accounts (e.g., planning estimate). Supply personnel shall not manage non-appropriated fund accounts (e.g., Morale Welfare Recreation funds).

010804. Supply personnel will not be assigned duties that conflict with their responsibility to maintain sound accountable records or influence or manipulate the accountability process.

0109 APPOINTMENT/RELIEF OF COMMANDING OFFICER, SUPPLY OFFICER/ACCOUNTABLE PROPERTY OFFICER, AND RESPONSIBLE OFFICER

010901. Commanding Officer / Accountable Officer

Per the reference (f), accountability is inherent to command. As such, the term CO is synonymous with AO unless specifically stated otherwise.

A. Before relief, the outgoing CO/AO will provide a Certificate of Relief letter to the relieving CO/AO. The Certificate of Relief letter will indicate the status of supply operations within the command and will be retained in the supply files for ten years (i.e., three years active and seven years archive). At a minimum, the letter will include an inventory summary; fiscal overview; status of existing temporary loans; status of pending investigations; and the status of garrison personal property accounts. In addition, the letter will include as an enclosure NAVMC 11867, "Roles and Responsibilities," identifying the appointment of key individuals involved with the management of property and finances within the organization. An example of a CO Certificate of Relief letter format can be found in Appendix G.

B. In cases of death, suspension from duty, transfer without relief, or any other instance where a Certificate of Relief letter cannot be obtained, the Major Subordinate Command (MSC), or other appropriate higher headquarters, will appoint an inventory board to determine the condition of materiel, records, and operating procedures. The inventory board will prepare a letter

reporting its findings to the MSC or higher headquarters. A copy of the letter will be maintained by the supply officer/APO, and the original of the board's letter will be provided to the MSC or higher headquarters. This will be documented as an endorsement to the outgoing CO's Certificate of Relief for retention.

010902. Supply Officer/Accountable Property Officer (APO)

A. Immediately prior to the relief of the supply officer/APO, an inventory and reconciliation of the property records will be accomplished. All approved adjustments resulting from the inventory will be made. Upon completion of the inventory and reconciliation of the property records, the supply officer/APO being relieved will prepare and sign a Certificate of Relief letter with the results of the inventory and reconciliation. At a minimum, the letter will include an inventory summary; fiscal overview; status of existing temporary loans; status of pending investigations; and the status of garrison personal property sub-accounts. The letter will include as an enclosure NAVMC 11867 discussed in paragraph 010901 above. An example of a Certificate of Relief letter format can be found in Appendix H. The supply officer/APO will provide this certificate, dated the date of relief, to the relieving supply officer/APO. The Certification of Relief letter will be retained in the supply files for ten years (i.e., three years active and seven years archive).

B. Within 30 calendar days after assuming control of the property account, the relieving supply officer/APO will conduct necessary supply inspections to determine the condition of materiel, records, and operating procedures. The findings will be reported to the CO/AO by endorsement on the outgoing Certificate of Relief. If additional time is required, a request for extension must be submitted to the CO/AO for adjudication. This endorsement will be maintained in the supply files for ten years (i.e., three years active and seven years archive).

C. If the supply officer/APO is separated from assets under his control for more than 60 calendar days due to temporary additional duty, hospitalization, or other reasons, the CO/AO must appoint another supply officer/APO. In cases of death, suspension from duty, or transfer without relief of an officer or noncommissioned officer (NCO) having charge of public property, the CO/AO will appoint an inventory board to determine the status of the account. If the CO/AO suspects that culpability exists for losses, then the CO/AO will direct that a Financial Liability Investigation of Property Loss be conducted in accordance with Chapter 7, Volume 12 (Special Accounts, Funds, and Programs) of reference (e).

D. Due to rapid account turnover, Certificate of Relief letters are not required for supply elements configured on a temporary basis to support a particular exercise (e.g., a Class IX block). For these accounts, relief of the supply officer will be conducted per local procedures established by the MARFOR/MEFs. Supply Officers assigned to deploying activities that are standing organizations (e.g., Marine Expeditionary Unit (MEU) Combat Logistics Battalion (CLB), Special Purpose Marine Air Ground Task Force (SPMAGTF), and etc.) will be appointed to manage all three activities associated to the deployment (i.e., organic account, secondary repairable sub-float account, and consumable account).

010903. Responsible Officer/Property Custodian

The outgoing RO/property custodian will report all property overages and shortages to the supply officer/APO before transferring responsibility for the property to the RO's successor. The incoming RO will conduct a joint inventory with the outgoing RO to validate the accuracy of sub-account records (e.g., CMR, CAR). If there is no RO presently assigned to the sub-account, the new RO will conduct an inventory to validate the accuracy of the sub-account's records. These actions will be accomplished within 15 calendar days of appointment as RO/property custodian. If the relieving RO is satisfied that property reflected on the property records is physically on hand and properly accounted for, he will sign the sub-account listing (e.g., CMR, CAR) and endorse his appointment letter, thereby acknowledging receipt of the equipment in the account. If the relieving RO is not satisfied with the condition of the account, he will sign the sub-account listing and endorse the appointment letter. The RO's endorsement will contain an itemized listing of all discrepancies for the account. The RO/property custodian will attempt to resolve all discrepancies with the supply officer/APO. All unresolved discrepancies will be reported to the CO, via the supply officer/APO, for possible investigative action. If required, a request for extension to the preceding time frame may be submitted to the CO for adjudication. RO appointment letters, endorsements (RO acceptance letter), and all supporting documentation will be maintained in the supply files for ten years (i.e., three years active and seven years archive).

0110 DELEGATION OF AUTHORITY AND SUCCESSION TO COMMAND

The U.S. Navy Regulations and reference (f) establish policy related to delegation of authority and succession to command which is set forth as follows.

011001. Delegation of Authority

When not contrary to law or regulations, COs may delegate specific authority to their subordinates to assist in the performance of their command functions; however, COs retain full responsibility for the performance of delegated duties. COs must ensure proper exercise of delegated authority and proper execution of orders and instructions.

011002. Succession to Command

This information regarding succession to command pertains to the CO only and not for those individuals appointed to execute the AO duties in accordance with paragraphs 020502 and 020503 of Volume 1 of this Order.

A. The U.S. Navy Regulations specify succession to command for CGs of OPFORs and subdivisions of OPFORs, COs of naval shore activities, and COs of aircraft units. Succession to command requires the completion of appointment letters and delegations of authority as stipulated in paragraph 0107. Except as otherwise provided for by law or by the U.S. Navy Regulations, succession to command in Marine Corps units shall be as follows:

1. Where there is a deputy, assistant, executive officer, chief of staff, or other officer specified by competent authority, that officer shall succeed to command in the event of the

transfer, death, or incapacity of the CO of the unit, and if the latter so directs, at other times during the absence of such officer.

2. Where there is no officer occupying one of the positions set forth above, the senior Marine Corps officer eligible to command and regularly assigned to the unit shall succeed to command in the event of the transfer, death, or incapacity of the CO.

B. When a CO is absent and has not directed succession to command during that absence, the officer who would otherwise succeed to command shall have authority to issue the orders required to carry on the established routine and to perform the administrative functions of the command. This authority is official upon completion of an appointment letter as stipulated in paragraph 0107.

C. An officer who succeeds to command assumes command responsibility for the unit, including all orders in force at the time and all public property and funds pertaining to the command. This includes, but is not limited to the authority to certify/sign vouchers, authorize adjustments to accounting records, and the authority to adjudicate requests for investigation from ROs/individuals. This authority is official upon completion of an appointment letter as stipulated in paragraph 0107.

D. An officer who succeeds to command during the temporary absence of the CO shall make no changes in the existing organization and shall strive to carry out the routine and other affairs of the unit in the usual manner. This authority is official upon completion of an appointment letter as stipulated in paragraph 0107.

011003. Deputy Commander

A deputy commander is an officer assigned by law, regulations, or orders of competent authority to succeed to command. A deputy shall always act for the commander in the absence of the commander. At such time as the commander is present, a deputy shall exercise command or control only over activities and matters specified or directed by the commander.

011004. Executive Officer (XO)

The XO shall be an officer of the organization who is eligible to succeed to command and normally will be the officer next in rank to the CO. As the direct representative of the CO, all orders the XO issues shall have the same force and effect as though issued by the CO. The XO shall enforce the policies and orders of the CO and shall be prepared to assume command at any time the need arises.

011005. Limitations on Succession to Command

A. Limited duty officers, chief warrant officers, and warrant officers may succeed to command only those activities that have a primary function corresponding to the military occupational specialty of the officer.

B. The officer succeeding to command of a Marine aircraft squadron, group, or wing, shall be a Marine Corps officer qualified as a naval aviator or naval flight officer.

011006. Level of Authority

Per Appendix A in Volume 1 of this Order, an officer succeeding to command must possess rank sufficient to carry out the full spectrum of responsibilities inherent to an AO (i.e., approving/voucher authority). When an officer succeeding to command does not possess the requisite level of convening authority (i.e., punitive/administrative action) to execute AO responsibilities relative to military justice (i.e., below the field grade level), the next higher authority in the chain of command (e.g., regimental or MSC commander) will adjudicate those matters.

011007. Appointment of Accountable Officer (AO)

Per Appendix A in Volume 1 of this Order, commanders, commanding generals, commanding officers, unit-level inspector-instructors do not require any further appointments as an AO beyond their orders. A commander/commanding general may appoint an officer not holding the "Command" title using DD 577 (e.g., MARFORs or Marine Expeditionary Brigade).

0111 TYPES OF MATERIEL

All materiel that retail-level supply activities uses or holds falls into two general categories: nonexpendable/expendable and non-consumable/consumable. The following definitions apply for all retail-level accounts.

011101. Nonexpendable/Expendable

Expendability determines the required accounting for a particular item.

A. Nonexpendable Supplies

Upon issue to the final user, nonexpendable supplies will be accounted for using custody procedures. Management techniques require centralized individual item management throughout the supply system to include items stocked at all inventory levels. Specifically, this includes items that, in the judgment of the Marine Corps, have a need for centralized inventory control. This includes centralized computation of requirements, procurement, IIP distribution, and accountability. In most instances, nonexpendable items are non-consumables and therefore recoverable. They are normally issued on a custody basis and are accounted for through allowance accounting policies; however, certain sensitive items such as ammunition and controlled medical supplies are accounted for as nonexpendable items although they are consumables. Nonexpendable items include general equipment as defined in Chapter 1 of Volume 1 of this Order and may constitute principal items, secondary items, or controlled items.

1. Principal Items. According to reference (d), an expendable principal item is a principal assembly or a replacement assembly of such importance to operational readiness that management techniques require centralized individual item management throughout the supply system to include items stocked at depot level, base level, and using unit level. This includes aircraft

engines, munitions and related equipment, tank subsystems, railway equipment, and propulsion systems. Principal assemblies do not include complete aircraft, ships, tanks, helicopters, other combat and tactical vehicles, intercontinental ballistic missiles, intermediate range ballistic missiles, or space vehicles.

2. Secondary Items. According to reference (d), a secondary item is an item of supply that is not defined as a principal item and includes reparable components, subsystems, and assemblies, consumable repair parts, bulk items and material, subsistence, and expendable end items, including clothing and other personal gear.

3. Controlled Items. Controlled items are a subset of nonexpendable supplies and include items designated as having characteristics requiring that they be identified, accounted for, secured, segregated, or handled in a special manner to ensure their security and integrity. Controlled items normally fall into the categories of classified, sensitive, and/or pilferable items and thus require more stringent inventory controls. The Commandant of the Marine Corps (CMC) (or higher authority) exercises close supervision of controlled items because such items are scarce, costly, or of a highly technical or hazardous in nature. Controlled items are assigned a Unique Item Identifier (UII) and are entered into the DoD Item Unique Identification Registry.

B. Expendable Supplies

Expendable supplies are items that are no longer accounted for after issued for consumption or applied to the end item application. For accounting purposes, most consumables and repair parts, regardless of price, are expendable; however, there are instances where the commodity level manages expendable items such as demand-support items. For more information on demand-support items, see paragraph 0213 of Chapter 2 in this Volume. Expendable supplies include operating materials and supplies (OM&S) as defined in Chapter 1 Volume 1 of this Order.

011102. Non-consumable/Consumable Supplies

While expendability determines the accounting required, consumable identifies whether or not the supply is actually consumed.

A. Non-consumable

This is an item of supply that remains intact after its intended use. Non-consumables (i.e., Secondary and depot-level reparable) are managed by RIPs, sub-floats, and MARCORLOGCOM. Non-consumables are accounted for as a part of an end item when attached to an end item or as a stand-alone item in serviceable or unserviceable inventory. Non-consumables may require serial-management per paragraph 0218. Non-consumables may also require a UII in accordance with reference (g). Non-consumables are accounted for until deemed uneconomical to repair and properly disposed of in accordance with disposition instructions and reference (h).

B. Consumable

This is an item of supply (except explosive ordnance) that is normally expended or used beyond recovery in the use for which it is designed or intended. Consumables are accounted for until issued to the end-item or debriefed to the requirement (not simply issued to end-user).

0112 DIRECTIVES AND PUBLICATIONS

011201. Publications Management

The Marine Corps publishes policy, procedural instructions, and reference publications for management of supply functions. In certain instances, publications of other services/agencies may be used. In accordance with reference (i), the Directives Control Point (DCP) within the administration section of the command manages publications. The DCP will use the Marine Corps Publications Distribution System (MCPDS) to manage and requisition publications within the unit. The CO shall ensure that all sections have on hand or on order all pertinent publications and directives with applicable changes. Printed copies, or copies located on computer hard drives, compact disks, digital video disks, or other memory storage devices, will suffice as long as they are current with all applicable changes and are deployable. Publications located on a network drive will not suffice as meeting the requirement of having pertinent publications and directives on hand as networks are not deployable and publications are not available when the network is down. The official online authoritative source for Marine Corps publications is the Marine Corps Publications Electronic Library at: <http://www.marines.mil/Pages/Default.aspx> (under 'News'/ 'Publications').

011202. Technical Publications Management

The availability of current technical publications has a direct impact on the ability to repair and maintain organizational equipment. Manage technical publications using the following tools:

A. Stock List 1-2

This lists all current technical publications, technical manuals, stock lists, supply instructions, technical instructions, and modification instructions in item designator (ID) number sequence and is published quarterly. Part III of the SL-1-2 lists superseded publications and the corresponding new publications. The SL-1-2 further identifies changes since the previous SL-1-2 by use of an asterisk (*) to the left of the appropriate publication control number.

B. Publication Library Management System (PLMS)

PLMS provides the same information as the SL-1-2 plus all directives and user manuals.

C. Marine Corps Technical Publications

The Marine Corps Technical Publications website is located at <https://portal.logcom.usmc.mil/sites/pubs/default.aspx>.

011203. Reconciliation Process

The supply section within retail activities will reconcile their portion of the unit's Publication Listing (PL) and Internal Distribution Control Form with the DCP quarterly upon receipt of NAVMC 2761, Catalog of Publications; the SL 1-2/1-3, Index of Publications Authorized and stocked by the Marine Corps; PLMS, or MCPDS and Marine Corps Bulletins in the 5600 series. This reconciliation will include a validation of those publications and directives on hand and on order. Units that maintain the PLMS are not required to maintain quarterly copies of the SL 1-2/1-3 or NAVMC 2761.

0113 PROCEDURES AND FOLDERS

011301. Standing Operating Procedures

MSCs, Marine Corps installations, and equivalent higher headquarters shall establish and publish local SOPs for internal supply management and operations. Local SOPs should focus on promulgation of geographically unique local procedures (e.g., building numbers and points of contact) or more stringent and detailed policy. Local SOPs should not paraphrase or reproduce policy or procedures in Marine Corps directives and users manuals. Battalion/squadron level SOPs are not mandatory. Instead, establish and maintain current turnover files and/or desktop procedures.

011302. Desktop Procedures and Turnover Folders

A. Desktop procedures will help reduce problems that personnel confront on a daily basis.

1. The frequent change of personnel within units results in a lack of expertise and continuity in day-to-day operations. Proper use of desktop procedures and turnover folders greatly alleviates this situation and improves the overall efficiency of an organization.

2. Each unit/section shall prepare desktop procedures for each billet involving administrative and management functions. Desktop procedures are not intended to be all inclusive, but rather a simple listing of significant items pertinent to daily operations within a particular billet. Normally, desktop procedures will include items such as current references, procedures for carrying out required duties, telephone numbers of key individuals, and reporting requirements.

B. Turnover folders, along with desktop procedures, greatly assist incoming personnel in becoming familiar with their assigned mission. Accordingly, turnover folders and desktop procedures will be continually reviewed and updated.

1. A turnover folder will include information about policy, personnel, status of pending projects, references, management controls, functioning of the section, ways of accomplishing routine or infrequent tasks, and other information of value to an individual assigned to that billet. At a minimum, turnover folders will contain statements concerning the following:

- a. Title of the billet.
- b. To whom the individual reports to.
- c. The mission of the billet (billet responsibilities).
- d. The functions involved in accomplishing the mission (principal action taken).
- e. Tasks and basic operations regularly performed in accomplishing specific functions.
- f. A list of orders or directives pertinent to the billet.
- g. A list of required reports and dates for submissions.
- h. List the relationship with activities both within and outside of the official chain of command, including unofficial liaison and coordinating functions.
- i. Personnel contacts within or external to the command, listing telephone numbers and/or addresses.
- j. List of internet resources for regular use in daily operations. Include web addresses and a brief description of each web site and their relationship to the billet.
- k. Miscellaneous information; for example, administrative or operational procedures peculiar to the billet such as dual responsibility for certain functions or limitations in responsibility or authority within particular functions.

2. Folders will be arranged to facilitate frequent updates.

C. Desktop procedures and turnover folders may be electronic or hard copy. Electronic desktop procedures and turnover folders will be maintained in a centralized location, backed up at least monthly, and support full access.

0114 RECORDS INSPECTION

011401. Supply accounting records will be analyzed and inspected by representatives of DoD, HQMC (i.e., FSMAO Teams, and ICART Teams), MSCs or equivalent higher headquarters, and as directed by the CO, to ensure that key supporting documents are being managed and retained as required.

011402. Analyses, metric performance reviews, examinations, and inspections will help assess the effectiveness of the retail activity's supply management operations, procedures, and methods. The analysis and review teams will also provide liaison, assistance, and guidance in the interpretation and application of Marine Corps supply instructions.

011403. Inspections by authorized personnel/agencies ensure command awareness of management, accountability, and compliance with higher headquarters' policy. Inspections validate an organization's capability to perform its assigned mission. Inspections should be used as a training and management tool.

0115 POLICY WAIVERS

011501. COs may request deviations from Marine Corps supply policy by submitting a written request to DC I&L (LP) via the appropriate chain of command. The request must provide a full justification and impact statement. As necessary, DC I&L (LP) may grant waivers for geographical peculiar instances and Marine Corps-wide deviations by. If approved, waivers will be for one year.

011502. After evaluating the impact of the waiver, DC I&L (LP) will make appropriate changes to Marine Corps policy. A request for waiver is not authorization to deviate from Marine Corps policy. Therefore, until the waiver has been approved in writing, units shall not deviate from the existing policy. DC I&L (LP) will only grant waivers for Marine Corps policy that DC I&L (LP) is responsible for.

0116 TRAINING

COs shall ensure that retail activity supply officers/APOs maintain an effective training program for all aspects of retail-level supply operations within the command. Training will be conducted in accordance with reference (j).

0117 INTERNAL CONTROLS AND AUDIT READINESS

011701. Per reference (k), commanders have a fundamental responsibility to develop and maintain internal controls over their processes to ensure that resources are efficiently used to achieve desired objectives and that resources used are in compliance with law and regulations with minimal potential for fraud, waste, and mismanagement. Effective internal controls provide reasonable assurance that significant weakness in processes that might adversely affect the achievement of desired objectives can be prevented or detected in a timely manner. Reference (l) provides the tools necessary to maintain effective internal controls.

011702. Supply Officers and APOs will use references (l), (k), and this Volume to ensure that proper implementation of semi-annual internal controls reviews are being administered and properly documented. These reviews, applicable Notices of Findings and Recommendations, and Corrective Action Plans will provide commanders reasonable assurance that effective and efficient supply internal controls are in-place for the command or the activity.

VOLUME 3: CHAPTER 2

“INVENTORY MANAGEMENT AND CONTROL”

SUMMARY OF SUBSTANTIVE CHANGES

All changes are denoted by **blue font** unless a full revision has been conducted.

Substantive revisions are denoted by a * symbol preceding the section, paragraph, table, or figure that includes the revision.

Hyperlinks are denoted by ***bold, italic, blue and underlined font***.

Base date of this Marine Corps Order (MCO) Volume (right header) will not change unless a full revision has been conducted. Upon full revision of this Volume, all changes denoted by blue font will reset to black font.

PAGE PARAGRAPH	EXPLANATION OF SUBSTANTIVE CHANGES	PURPOSE	DATE OF CHANGE

CHAPTER 2

INVENTORY MANAGEMENT AND CONTROL

0201 GENERAL

The Marine Corps mission requires a high degree of operational readiness so that tasks assigned can be accomplished. The CO is the AO and exercises command responsibility of supply operations, property control must be meticulously maintained. A CO will not be restricted from exercising the prerogative of directing intra-command distribution of supplies and equipment to accomplish operational requirements. At the retail level, inventory used to support operational requirements includes the two categories of allowance items and demand supported items. The following guidance and procedures apply.

0202 ALLOWANCE ITEM INFORMATION

The Marine Corps uses several methods of identification and classification to distinguish between allowance items. These include the classes of supply, NSN or National Item Identification Number (NIIN), Marine Corps Stock Number (MCSN), TAMCN, SAC, and UII.

020201. Classes of Supply

All supplies found in the Marine Corps inventory are grouped into 10 classes and further divided by subclass. See Appendix I.

020202. National Stock Number (NSN)

The NSN is a 13-digit number used to identify items and is assigned by the Defense Logistics Information System (DLIS). The NSN is used in the Federal Logistics Information System (FLIS) to convey specific information about an item of supply. It is comprised of the Federal Supply Class (FSC), which is the first four digits, and the NIIN, which are the last nine digits.

A. National Item Identification Number (NIIN)

The NIIN is the last nine digits of the NSN that differentiates each individual supply item from all other supply items. The first two digits signify the National Codification Bureau that assigned the NIIN, while the last seven digits are non-significant and are sequentially assigned by the FLIS.

B. NSNs and NIINs are assigned to items of supply in the Federal Supply System (FSS) that are recurrently used, bought, stocked, managed, or distributed. These items are named, described, classified, and numbered so only one distinctive combination of numerals (an NSN/NIIN) identifies the same item throughout the FSS. This includes, but is not limited to, items selected for centralized management, procurement, and stockage, including both centrally and locally procured items, and items stocked in retail-level installations to support local requisitions.

C. The DLIS assigns all NSNs at the request of the military Services, certain federal and civil agencies, and foreign friendly countries. Each NSN assigned to an item of supply is the result of a careful review process known as cataloging. During the process, each item of supply is named, assigned an FSC, described to identify all known characteristics and performance data, and ultimately assigned an NSN. This information is maintained in FLIS and is managed by the DLIS. DLIS is the only organization authorized to assign NSNs.

D. References (m) and (n) provide a complete listing of NSN assignment criteria and request procedures.

020203. Management Control Number (MCN)

The DPAS allows for the creation of locally assigned stock numbers called Management Control Numbers (MCN). MCNs are used for items that do not already have an NSN cataloged in FLIS. When accounting for property within DPAS, units will use the NSN for items that have an NSN cataloged in FLIS. For items that do not have a NSN cataloged in FLIS, units will request and use a MCSN as the MCN within DPAS. For additional policy and procedures refer to paragraph 020204 and reference (n).

020204. Marine Corps Stock Number (MCSN)

A MCSN is a 13-digit designator assigned by MARCORLOGCOM to support numerous non-traditional support methodologies, such as contractor logistics support, just-in-time inventory, and out-of-stores initial issue. The MCSN provides the capability to uniformly record item information in all DoD supply chain systems. A MCSN is only assigned when it is neither possible nor practical to assign an NSN, or the item is considered to be excluded from the Federal Catalog System. This includes, but is not limited to, items procured on a one-time basis for immediate use in research and development, experimentation, construction, installation or maintenance, and items being fielded prior to the availability of technical data to support cataloguing actions. For a complete listing of MCSN assignment criteria and request procedures refer to reference (n).

020205. Table of Authorized Materiel Control Number (TAMCN)

The TAMCN is the chief method of identifying equipment capabilities, and is assigned by HQMC. Several NSNs/NIINs can fall within the same TAMCN (e.g., D01987K, Truck Cargo 7T). The TAMCN consists of three elements: the commodity designator, the item number, and the class (and subclass) of supply. TAMCNs typically fall under one of five commodities: (communications/electronics, engineer, general supply, motor transport, and ordnance), and five types of property. See Appendix J for a detailed listing.

A. Type 1 TAMCN items are defined as non-expendable military equipment with requirements established by HQMC based on formal Table of Organization mission statements. Type 1 TAMCNs have an "A" through "E" commodity designator and a cataloged NSN.

B. Type 2 TAMCN items are defined as non-expendables which are ancillary to Type 1 TAMCN items with initial requirements established by HQMC based on local mission

requirements. Type 2 TAMCNs have "H", "J", "K", "M", and "N" commodity designators and a cataloged NSN.

C. Type 3 TAMCN items are defined as non-expendable military equipment that require special measures of control since they are used for particular conditions or situations (e.g., items which are uniquely required in cold weather or desert operations). Such items are typically not held at the unit level, but temp-loaned as the operational status of a unit may require. Standard Type 3 TAMCNs have a "T" through "X" commodity designators and a cataloged NSN.

D. Non-Standard Equipment (NS-E) is defined as non-expendable equipment that is rapidly acquired and fielded to bridge mission capability gaps to meet urgent warfighter requirements or commercially purchased to support garrison requirements. N-SE can be either tactical (military equipment) or non-tactical (garrison property).

1. Tactical NS-E is defined as military equipment that is rapidly acquired and fielded via an UNS or UUNS to meet urgent warfighter requirements, support assigned mission capabilities, or force protection. Tactical NS-E will be accounted for in the ground equipment APSR (e.g., GCSS-MC). Tactical NS-E can be assigned any TAMCN commodity designator, but will always have a MCSN rather than a NSN/NIIN cataloged within FLIS. If a Tactical NS-E item becomes a program of record (i.e., assigned to a Program Manager / Product Manager, funded, and cataloged in TFSMS with a TAMCN), the MCSN will be replaced with NSN that is cataloged in FLIS.

2. Non-Tactical NS-E is defined as non-expendable garrison property that is commercially purchased to support administration, base operations functions, and garrison support services. This includes NS-E used by service support contractors whether provided as Government Furnished Property (GFP) or Contractor-Acquired Property (CAP). Non-Tactical NS-E is not considered for program of record candidacy and will be accounted for in DPAS with a MCSN or NSN. The following items are examples of Non-Tactical NS-E:

- a. Inert small arms trophy weapons;
- b. Band equipment;
- c. Office equipment (e.g., copiers, scanners, cameras, televisions and monitors, display equipment, etc.); and
- d. Inert ceremonial weapons.

E. Special Item Equipment (SIE) is defined as non-expendable assets provided to support Marine Corps commands/activities conducting special operation missions at the Combatant Command (COCOM) or national security levels. SIE will be assigned a "Q" TAMCN commodity designator, regardless if those assets were provided to the Marine Corps on a permanent or temporary basis.

020206. Stores Account Code (SAC)

The SAC is used to differentiate between items that are financed through different methods.

A. SAC 1

Items funded through the DON stock fund account (SFA) (Marine Corps Division) or Operations and Maintenance, Marine Corps (O&M, MC), which are normally low cost and high demand, and are the budget responsibility of the requesting unit.

B. SAC 2

Repairable secondary items that are stocked, stored, issued, procured, and repaired below the depot level and are financed through appropriations other than the DoD working capital funds. The RIP submits funded requisitions and holds the budget responsibility for requesting SAC 2 items. Using units are not authorized to requisition SAC 2 items. Instead, using unit will source SAC 2 items via the RIP and sub-float activities.

1. Program Manager (PM) procured modification kits used to upgrade weapons systems quickly and economically are stocked as SAC 2 items. These kits will be issued on a non-reimbursable basis (i.e., free issue).

2. Only SAC 2 controlled items required to support Marine Corps Forces Special Operations Command (MARFORSOC) operations with a Controlled Item Code (CIC) of "J," as cataloged by other DoD agencies will be captured in the allowance management information system (i.e., TFSMS) and ground military equipment APSR.

C. SAC 3

Military equipment of major importance; and major components that require detailed analysis and examination; are financed through appropriations other than the DON SFA (Marine Corps Division) and are not the requesting unit's budget responsibility.

020207. Unique Item Identifier (UII)

DoD UII is a system of marking items delivered to the DoD with UIIs that have machine-readable data elements to distinguish items from all other like and unlike items. For items that are serialized within the enterprise identifier, the UII will include the data elements of the enterprise identifier and a unique serial number. For items that are serialized within the part, lot, or batch number within the enterprise identifier, the UII will include the data elements of enterprise identifier; the original part, lot, or batch number; and the serial number. "Enterprise" refers to the entity (e.g., a manufacturer or vendor) responsible for assigning UIIs to items. The enterprise identifier is a code that is uniquely assigned to an enterprise by an issuing agency. Within the Marine Corps, UII is a 50-character data string that represents the machine-readable, two-dimensional dot matrix mark which contains all pedigree data of that particular item. Some of the pedigree data includes: serial number, part number, contract number, Commercial and Government Entity (CAGE) code,

Department of Defense Activity Address Code (DoDAAC), etc. Refer to reference (h) for policy and additional guidance.

0203 ACQUISITION OBJECTIVE

Reference (o) defines Acquisition Objective (AO) as the required quantity of a new item, broken down by unit (to the Unit Identification Code (UIC) level of detail) based on the concept of employment/concept of distribution, and documented in the TFSMS as an unfunded requirement in a pending request. This establishes the total requirement for a TAMCN across the FYDP and is briefed to the Marine Corps Requirements Oversight Council (MROC) for approval. Once the AO is approved by the MROC it becomes the Approved Acquisition Objective (AAO).

0204 APPROVED ACQUISITION OBJECTIVE (AAO)

References (d) and (o) define an AAO as the quantity of a given item authorized for peacetime and wartime requirements to equip and sustain U.S. and allied forces. It represents the total approved materiel quantity for each TAMCN required by all units for peacetime and wartime missions. AAOs are categorized into the OPFORs and Reserves, SE, and War Reserve Materiel Requirement (WRMR). WRMR consists of prepositioned equipment ashore (e.g., Norway, Kuwait, Albany, etc.), Depot Maintenance Float Allowance (DMFA), and afloat (e.g., Maritime Prepositioning Ships (MPS)).

0205 ALLOWANCE ITEMS

Allowance items are military equipment (supply classes VII and II) and are formally published by DC CD&I, Total Force Structure Division (TFSD) via unit Tables of Organization and Equipment (TO&E). Allowance changes are requested and authorized by the CMC per reference (o). Every unit CO who has an allowance or special allowance established by the CMC will maintain a formal account to control items. Refer to reference (p), for policy and procedures pertaining to GME allowances.

020501. Table of Equipment (T/E) Allowances

AAOs for military equipment are represented in TFSMS as T/E allowances. These quantities represent the organization's full wartime requirement for allowance item, at the UIC level, against which readiness is reported. Each T/E allowance quantity is a critical number since it is the AAO quantity that is transferred from TFSMS to the APSR for supply, and reported at the unit DoDAAC level for centrally managed items.

020502. Type 1 Allowances

Except for items managed under a CSP or when specifically directed by higher authority, OPFORs and SEs are required to have all Type 1, SAC 1, T/E allowances on hand, on order, or identified as an unfunded deficiency. Type 1, SAC 3 centrally managed items will be sourced to commands via the ground equipment inventory manager at MARCORLOGCOM. Thus, all items that have a HQMC-assigned Type 1 TAMCN associated to them will be accounted for on unit property records and have associated allowances formally established, regardless of the method of

13 JUN 2016

purchase or type of funds used. SAC 3 items will be distributed to deficient units based on operational requirements established by HQMC. A TOECR must be submitted to DC CD&I (TFSD) via the chain of command to increase, decrease, add, or delete an established Type 1 allowance.

020503. Type 2 Requirements

Requirements for the initial fielding of Type 2 TAMCN items are established by DC CD&I on organizational TO&Es in TFSMS; however, MEF/SE/MARFOR commanders have the flexibility to adjust Type 2 requirements via the TOECR process after initial fielding for their subordinate commands. The following policy applies:

A. The MEF/SE/MARFOR Commander or equivalent higher headquarters will ensure that Type 2 reviews are conducted annually to validate or establish approved requirements for subordinate commands with property accounts. In addition to the TOECR process, the MEF/SE/MARFOR Commander or equivalent higher headquarters will authorize in writing all Type 2 requirement adjustments, additions, and deletions.

B. Since replenishment and replacement of Type 2 TAMCN items is a unit-funded responsibility, the MEF/SE/MARFOR Commander or equivalent higher headquarters will ensure that requirements identified in the MSC-level T/E reviews can be supported with unit Operations and Maintenance (O&M) funding. Units will ensure that all Type 2 T/E review approval documents are maintained for ten years (i.e., three years in the supply active file and seven years in the supply archive file).

C. To add, delete, or change a Type 2 requirement in TFSMS, units must submit a TOECR to DC CD&I (TFSD) via the chain of command and MARCORSYSCOM. MARCORSYSCOM will validate, endorse, and forward to DC CD&I (TFSD) all Type 2 T/E TOECRs for MARCORSYSCOM-managed items within 30 business days of receipt.

D. Units will not submit Type 1 and Type 2 T/E changes on the same TOECR. This will ensure that all Type 2 TOECRs are correctly routed to MARCORSYSCOM for review and endorsement before being routed to DC CD&I (TFSD) for final approval.

E. Approved Type 2 requirements will be on hand, on order, or identified as an unfunded deficiency.

020504. Type 3 Requirements

Type 3 TAMCN items are for use under particular conditions or situations such as tropical, extreme cold weather, desert conditions, or combat operations. Type 3 requirements reside at the MEF-level and are provided for either war materiel initial issue to units whose mission will likely place them in of the above conditions or situations, or for familiarization and training. Type 3 TAMCN items are centrally managed by the CSP, which is managed by MARCORLOGCOM. Type 3 TAMCN items are typically not held at the unit level, but are temporarily loaned to units by the CSP for the MEF. The following policy applies:

A. Units are responsible for requesting and coordinating Type 3 TAMCN items through their MSC.

B. Type 3 TAMCN items are to be requested and provided only for its intended use or as prescribed by the appropriate MARCORSSCOM program manager.

C. Temporarily loaned Type 3 TAMCN items will be returned to the CSP within 30 days of completing the operation or exercise for which the materiel was provided.

020505. Non-Standard Equipment (NS-E) Requirements

Requirements for Tactical NS-E are established by DC CD&I (TFSD) on organizational T/Es. Tactical NS-E requirements are established during the UNS or UUNS process. Units will validate Tactical NS-E requirements on an annual basis in conjunction with the Type 2 TAMCN review. For subsequent adjustments to Tactical NS-E requirements (increases, decreases, or deletions), units will submit T/E changes (using Appendix Q) directly to MARCORLOGCOM via the unit's chain of command. For units that possess Tactical NS-E that does not have an existing TAMCN in TFSMS, units will submit an UNS via the Virtual UNS system to validate the requirement in accordance with references (q) and (r). Units will account for Tactical NS-E TAMCN items in GCSS-MC and Non-Tactical NS-E items in DPAS. Tactical NS-E TAMCNs are authorized for two-years and will not be renewed unless the item becomes a program of record and the MCSN is replaced with an NSN. For purchases of Non-Tactical NS-E, the unit's supply officer will submit a purchase request (PR) to the Installation Personal Property Manager (PPM) for procurement. Supply Officers not supported by a Marine Installation PPM will ensure that Non-Tactical NS-E is procured via PR Builder. Upon receipt of Non-Tactical NS-E, units will account for these assets in DPAS.

020506. Special Item Equipment (SIE) Requirements

Units in receipt of SIE items will submit the initial T/E requirements for update into TFSMS directly to MARCORLOGCOM via the chain of command using Appendix Q. Units will validate SIE requirements on an annual basis in conjunction with the Type 2 TAMCN review. For subsequent adjustments to SIE requirements (increases, decreases, or deletions), units will submit T/E changes (using Appendix Q) directly to MARCORLOGCOM via the unit's chain of command. For SIE items that are provided by USSOCOM or the NSA only, units will submit a request for an SIE TAMCN to DC, I&L (LP) via the chain of command. Upon request from the MARFORs, DC I&L (LP) will task MARCORLOGCOM to create SIE TAMCNs. Units will account for SIE TAMCN items in GCSS-MC.

020507. Allowances for Consolidated Storage Program (CSP) Managed Equipment

For most OPFOR units, certain per-individual and unit equipment items are managed by a CSP. Items managed by the CSP are further defined as Individual Combat Clothing and Equipment (ICCE); Chemical, Biological, Radiological, and Nuclear Defense; Soft-Walled Shelters and Camouflage Netting; and Special Training Allowance Pool assets. CSP allowances are based on a consolidation of the supported unit's TO&Es. Under this program, organizational TO&E allowances remain in TFSMS, but the CSP maintains full equipment accountability. Units not

supported by a CSP will account for organizational equipment per the guidance published in this policy. Refer to Volume 13 of this Order for policy and additional guidance.

020508. Readiness Reportable Equipment

Readiness reportable equipment is published annually in Marine Corps Bulletin 3000 documents, and readiness reporting policy is outlined in reference (s). Readiness reportable equipment may also include items in the CSP and require readiness reporting, visibility, and accountability. To ensure accurate ground equipment readiness reporting, visibility, and accountability of T/E assets, command adjustments may be warranted. Refer to paragraph 0207 in this chapter for more information on command adjustments.

020509. Special Allowances

Units may request the establishment of a special allowance and the resulting authority to receive equipment from MARCORLOGCOM inventory stores to fill emerging short-term operational requirements. Units must route requests for special allowances to the unit's chain of command (e.g., MEF G3/G4 to MARFOR G3/G4) via naval message. The unit's chain of command will validate, endorse, and forward the request to MARCORLOGCOM via naval message. MARCORLOGCOM will conduct a feasibility of support to determine the asset availability. If the request is not supportable, MARCORLOGCOM will notify the requesting unit and the unit's chain of command via naval message. If the request is supportable, MARCORLOGCOM will endorse and forward the request to DC I&L (LP) via naval message. DC I&L (LP) will request a risk assessment from DC PP&O (PO). If DC PP&O (PO) deems the risk as acceptable, DC I&L (LP) will release a naval message authorizing the special allowance. Requests must contain the UIC, AAC, impact statement to the unit mission, item description (TAMCN, NSN, nomenclature, current authorization, current on-hand, recommended adjustment), justification, ship-to address, accountable point of contact (supply officer), and any additional supporting documents. Special allowances are intended to fill emerging short-term operational requirements (e.g., Research and Development (R&D) testing, emerging COCOM requirement) and approvals will not exceed one year. Enduring requirements requiring long-term adjustment to established allowances will continue to be submitted via a TOECR to DC CD&I (TFSD) via the chain of command for staffing through the development process. In accordance with paragraph 0207, units with an approved special allowance will initiate a positive command adjustment within the ground equipment APSR and maintain a copy of the approved special allowance documentation on file.

020510. Training Allowances

Training allowances (T/As) are unique to the Reserve Component and are defined as the minimal amount of T/E assets required to conduct unit-level training based on Mission Essential Tasks (METs) in consideration of facility space, manpower, fiscal and maintenance constraints. Training allowances are established only for Type 1 TAMCN items necessary to maintain training to core METs. They are a subset of the unit's wartime requirement (T/E). Reserve units are not required to maintain full T/E allowances, but instead are authorized the establishment of T/As for Type 1 TAMCN items. Training allowances must be established, in writing, by the Commander, Marine Forces Reserve (COMMARFORRES). This authority may be delegated in writing to the MSC level (e.g., CG, 4th Marine Division).

13 JUN 2016

A. Training allowances will be reflected in the unit's property records using a command adjustment in accordance with paragraph 0207 of this chapter. The total allowance field in the ground equipment accountability APSR will reflect that quantity as approved by the COMMARFORRES or MSC Commander. Total T/A will not exceed the aggregate of MARFORRES T/E allowances.

B. Training allowances will be reviewed and updated bi-annually (i.e., every two years).

C. Equipment represented by the delta between T/A and T/E will be held at MARCORLOGCOM as In-Stores assets if MARCORSYSCOM procurement actions have been completed; or will be identified as an unfunded WRMR deficiency.

020511. Research and Development Items

Items maintained or provided for R&D by MARCORSYSCOM will be accounted for per this policy. Refer to paragraphs 020505 and 020509 of this chapter for additional information.

020512. Equipment Sets for Task-Organized Units

Equipment sets that support task-organized units (e.g., SPMAGTFs, rotational forces) belong to the supported MARFOR. As such, the supported MARFOR is responsible for the readiness and sustainment of the equipment sets. This includes equipment rotation planning; as required. Once the supported MARFOR assumes control of the equipment set, the supporting (e.g., sourcing) MEFs is no longer accountable for task-organized unit's equipment sets. Equipment sets include both enduring requirements and rotational requirements (i.e., specific to a given task-organized unit's mission and subject to change). Task-organized units having equipment needs in-excess of their unit T/E requirements (e.g., "above"-T/E or greater than T/E), not included in their T/E (e.g., "beyond" T/E) and those non-standard units (e.g., SPMAGTFs) and attachments without a T/E, will develop and submit a list of equipment needs, also known as an Equipment Density List (EDL) for review and validation to the force providing MEF, and supporting / supported MARFORs. This EDL includes all of the equipment needs for the unit (e.g., T/E, above-T/E, and beyond-T/E). The following policy applies:

A. Validation of MARFORSOC/MARFORSOF deployed EDLs are done by the gaining Theater Special Operations Command (TSOC) instead of the theater MARFOR. The theater MARFOR is apprised of the EDL via the statement of requirements.

B. EDLs are not additive to the AAO and do not generate a demand signal or requirement that increases the AAO for individual TAMCNs. EDLs do not trigger procurement actions that would cause an increase of the AAO.

C. The supported MARFORs will ensure proper oversight and timely submission of EDLs by standing up a working group/operational planning team for EDL development and validation in support of tasked-organized unit equipment. MARFORs and tasked-organized units will leverage subject matter experts from the MEFs to facilitate EDL development

13 JUN 2016

and validation. Direct liaison with MARCORSYCOM and Marine Corps Combat Development Command is authorized for non-sourcing actions and technical support/subject matter expertise (e.g., obsolete items, incorrect associated equipment, the proper ratios of equipment being requested, Urgent Universal Need Statement (UUNS) items / special equipment items, theater specific equipment, etc.).

D. In accordance with reference (t), the supported MARFORs will submit validated EDLs or modifications to already approved EDLs to HQMC, DC PP&O (POE) for approval and DC I&L (LPO) for assistance with equipment sourcing solution, if required. The EDL will be forwarded via naval message no later than 90 days prior to the required delivery date (RDD). At a minimum, EDLs should contain the TAMCN, nomenclature, model (if applicable), and quantity.

E. Once HQMC approves an EDL via naval message, the supporting MARFOR will use Section Five of the TFSMS User Manual - Change Request - Equipment to submit a TOECR to establish the approved EDL in TFSMS to document the requirements for task-organized units in accordance with paragraph 020512. Section Five of the TFSMS User Manual is available at https://tfsms.mccdc.usmc.mil/portal/page/portal/TFSMS/MAIN/TAB_HELP.

F. For modifications to an approved EDL (e.g., during the review at each force rotation or post-initial operating capability), supported MARFORs will follow the process outlined in paragraphs 020512.C. through 020512.E.

G. MARFORs will ensure TFSMS super users use the task-organized functionality and work flow to facilitate active EDL management.

H. EDLs for rotational forces, SPAGTFs, and task-organized units will be reviewed, updated and revalidated by the MARFORs during each force rotation. This revalidation will be provided via naval message to DC PP&O (POE) and DC I&L (LPO) for approval to ensure active management and reconciliation of the EDL within TFSMS.

I. T/E Management / Allowancing / Reporting

1. Supporting units transferring equipment to task-organized units will continue reporting equipment readiness against AAO and T/E allowances in TFSMS.

2. Supporting units will not induct negative command adjustments for the transfer of equipment to task-organized units.

3. Units assigned a provisional UIC by DC PP&O (POR) or task-organized units using their TFSMS UIC and having an assigned mission will use the approved EDL to report equipment readiness in Defense Readiness Reporting System-Marine Corps (DRRS-MC). Equipment lists within DRRS-MC for these units will be populated by the DRRS-MC user, consistent with the EDL.

4. Supported task-organized units receiving equipment transfers from supporting units will report equipment readiness against the approved EDL per references (s) and (u).

13 JUN 2016

5. Supported task-organized units will induct positive command adjustments in the appropriate APSR (e.g., GCSS-MC) to accurately capture the approved EDL for the transfer of military equipment from supporting units. Task-organized units maintaining their TFSMS UIC will only perform positive command adjustments for equipment needs above-T/E and beyond T/E.

6. The duration of command adjustments will follow the policy listed in paragraph 0207.

7. Sourcing/supporting units must be cognizant of any negative changes to the unit's resource level (C-level) as a result of providing equipment to a supported unit; particularly if changing from a state of readiness to unreadiness (i.e., C-1/2 to C-3/4). Commanders must consider the readiness risks to the sourcing unit and comment accordingly in the unit's DRRS-MC report or consider alternate methods of sourcing equipment to the supported/task organized unit.

J. Equipment Sourcing

1. Equipment Density Lists (EDLs). The primary source of equipment for task-organized units will be the parent MEF of the deploying unit, followed by the force providing MARFOR.

2. Global Sourcing

a. If the force providing MARFOR cannot source all of the equipment needs, the force providing MARFOR will identify by message to DC PP&O (POE), DC I&L (LPO), and the supported/theater MARFOR, the mission critical equipment that cannot be sourced. To be considered for global sourcing, this should be done no later than 60 days prior to the RDD. Justifications must be provided for all global sourcing requests and include an analysis of the supporting MARFOR's allowances, on-hand end-item posture, level of risk to operations, training assumed by providing the mission critical items, and citation of applicable operation plans /contingency missions.

b. In cases where the force providing MARFOR cannot source all of the equipment on the approved EDL, DC I&L, as the EGEM, and MARCORLOGCOM, as the Enterprise Ground Equipment Inventory Manager, may recommend enterprise solutions based on the enterprise asset posture and a feasibility of support from potential sourcing organizations. For sourcing solutions with non-excess cross-leveling actions, DC I&L will direct cross-leveling upon DC PP&O's determination and approval based on the acceptable level of risk.

c. When cross-leveling is directed, sourcing / supporting units will transfer accountability and responsibility of end items in the appropriate APSR.

d. Global sourcing means that equipment could "move around" within one pillar of the AAO (e.g., within the OPFOR from a MEF to a task-organized unit) or from one pillar of the AAO to another (e.g., War Reserve Materiel Requirement-In-stores to the OPFOR in support of a task-organized unit).

13 JUN 2016

e. Global sourcing does not trigger new procurement or backfill automatically. Pillars of the AAO with lower priorities will likely be impacted by global sourcing. As an example, strategic level programs like Marine Corps Prepositioning Program-Norway and WRMR-I can be potentially at risk for their wartime missions, if used as a sourcing option.

f. Equipment requiring un-programmed procurement, AAO increases, or both to meet the needs of task-organized units are addressed via the UUNS process in accordance with reference (q). The supported MARFOR will coordinate with DC CD&I to register an urgent need for approved equipment requirements that do not exist in the Marine Corps or joint service inventory in accordance with paragraph 4.e.(6)(e) of reference (t).

g. Theater specific/unique equipment will be provided by the supported MARFOR, as applicable (e.g., ground based operational surveillance system, mine rollers, etc.).

h. If MARFORRES equipment is used as a sourcing solution, the equipment must be returned to MARFORRES in less than 90 days or reported to the Secretary of Defense in accordance with reference (v).

3. Equipment Rotation

a. If the supported MARFOR determines that an equipment rotation plan needs to be established, the supported MARFOR will host and identify equipment rotation requirements at an equipment review conference per paragraph 020512.M. At this conference, representatives from the supported MARFOR, supporting MARFORs, and the deployed task-organized unit will meet with relevant subject matter experts from HQMC and the SE (e.g., MARCORLOGCOM, MARCORSYSCOM, etc.) to discuss what equipment needs to be rotated, the frequency, potential replacement sourcing solutions, and the maintenance strategy for the equipment being rotated.

b. It is imperative that the appropriate subject matter experts from HQMC, the MARFORs, MARCORLOGCOM and MARCORSYSCOM attend the equipment review conference.

c. The primary source for backfilling equipment rotations in support of task-organized units is unit T/E excesses or MARCORLOGCOM in-stores assets. Paragraph 020512.L provides additional policy and guidance.

d. If the force-providing MARFOR cannot source all of the rotational equipment, refer to paragraph 020512.J.2.

K. The TSOC sources common use requirements in support of MARSOF. Marine Corps unique, Title 10 requirements will be provided to the theater component for a sourcing solution when approved by DC I&L.

L. Backfills to T/E Requirements as a Result of EDL or Equipment Rotation
Plan Sourcing

1. Any deficiencies created as a result of organizations providing equipment in support of task-organized or provisional units will be managed via the quarterly push fulfillment process.

2. For backfills in advance or outside of the push fulfillment process, HQMC approval is required to ensure that the deputy commandants for PP&O, CD&I, and I&L have visibility on the impact of potential backfills to the pillars of the AAO (e.g., WRMR-I, DMFA, etc.) and overall equipment disposition (e.g., strategic level programs, the delta between MARFORRES T/E and T/A, etc.).

3. MARFORs seeking backfills for equipment sourced to task-organized units or rotational forces, in advance or outside of the push fulfillment process, will identify in message traffic to DC I&L (LPO) the equipment requested and provide a justification/risk assessment of not backfilling. DC I&L and MARCORLOGCOM will recommend enterprise solutions based on the enterprise asset posture and a feasibility of support from potential sourcing organizations. For sourcing solutions with non-excess cross leveling actions, DC I&L will direct cross-leveling upon approval from DC PP&O.

4. MARFORs and the MEFs will identify equipment sourced to task-organized forces during MARCORLOGCOM's quarterly push equipment sourcing report / process. This serves an internal control to ensure that MARCORLOGCOM and the MARFORs have visibility of equipment sourced to EDLs.

5. MARCORLOGCOM will not source (e.g., backfill) any equipment shortages to the OPFORs (in advance or outside of the push fulfillment process), if the shortage was created by sourcing items to a task-organized unit unless approved by HQMC in accordance with paragraph 020512.L.3.

M. Sustainment

The supported MARFOR will host an equipment review conference to codify equipment sustainment planning and necessary changes to the equipment needs list. At this conference, representatives from the supported MARFOR, supporting MARFORs, and the deployed task-organized unit will meet with relevant subject matter experts from HQMC and the SE (i.e., MARCORLOGCOM, MARCORSYSCOM) to register sustainment requirements and discuss potential alterations to equipment needs to include increases, decreases, replacements and rotations. For situations whereby a task-organized unit is gained by a MARFOR after the conference has elapsed, HQMC, MARCORLOGCOM, and MARCORSYSCOM may schedule a remedial working group to address emerging sustainment requirements.

N. Maintenance

To the maximum extent possible, MARFORs will use the intermediate level capability of the task-organized unit and in-theater capabilities, where available and practicable. In cases where it is necessary, the supported MARFOR, assisted by MARCORLOGCOM, will use in-theater intermediate overflow maintenance capabilities, where available and practicable, to sustain Marine Corps equipment. When required, the task-organized unit, and the MARFOR to which they belong, will request disposition instructions from MARCORLOGCOM when the equipment requires maintenance beyond the capability of the task-organized unit or in-theater capabilities. In the request for disposition instructions, the task-organized unit will identify a need for replacement and the required delivery date. MARCORLOGCOM will treat all requests for disposition instructions from task-organized units in the same manner as a MEU and provide a replacement. For equipment sets that are scheduled to rotate out of theater (e.g., task-organized unit is redeploying), the task-organized unit will request disposition upon the task-organized units return with the equipment set. Refer to paragraph 020512.J.2 for situation when items cannot be sourced to support a request for replacement.

O. Equipment Return at End of Mission

1. Prior to end of the mission, representatives from HQMC (e.g., DC PP&O, DC I&L, etc.), the SE (e.g., MARCORLOGCOM, MARCORSSCOM, etc.) and the MARFORs will develop an equipment retrograde plan to mitigate risk across the enterprise, maximize resources and ensure sourcing units receive appropriate equipment sets in serviceable condition, aligned with CMC equipping priorities and the reset strategy for each TAMCN.
2. Prior to the retrograde and redeployment of the equipment set supporting a task-organized unit used in support of a rotational commitment, the theater MARFOR will request disposition instructions for all military equipment, UUNS items, theater specific equipment, and OM&S from the ground equipment inventory manager (MARCORLOGCOM). This enables the ground equipment inventory manager to push/pull items to satisfy shortfalls across the pillars of the AAO and avoids unnecessary transportation costs.
3. If the deployment of a task-organized unit is not associated to a rotational commitment (e.g., it stands up to perform a Humanitarian Assistance/Disaster Relief mission and returns to the parent MEF/MARFOR without having to rotate manpower), the equipment set should return to the sourcing MEF/MARFOR.

0206 ALLOWANCE ITEM MANAGEMENT

Per references (d) and (w), a minimum 98 percent physical inventory accuracy rate must be achieved and maintained for the management of allowance items; and 100 percent accuracy for classified or sensitive property and items with a CIC of "A." Allowance and serially managed items, to include parent/child relationships, will be accounted for and managed in the appropriate supply APSR (i.e., GCSS-MC for military equipment). In most instances, these items will be issued to an RO or responsible individual (RI) for custody/sub-custody.

020601. Commanding Officer / Accountable Officer (AO)

Per the reference (g), accountability is inherent to command. The CO (or designated representative in those organizations where the CG is also the AO) is the AO of a retail-level supply activity and has the overall responsibility for ensuring accounting records are current, complete and accurate. The CO or designated representative (as applicable), as the AO, must ensure sound supply procedures are conducted, to include all applicable inventories, submission of all required reports, completion of investigations, processing of adjustments, and the proper issue and recovery of equipment. In addition, only the CO or designated representative who is the AO (as applicable) has the authority to approve certain adjustments to the accounting records. Some organizations (i.e., SE) have a CG carrying out the CO supply duties. As such, the CG can delegate his AO responsibilities to a designated authority (i.e., Assistant Chief of Staff G-4).

020602. Supply Officer / Accountable Property Officer (APO)

The supply officer/APO manages property accounting functions on behalf of the CO and has the responsibility to ensure that accounting systems and records are accurate at all times. The supply officer/APO is the official conduit for property arriving at or leaving a unit and will ensure the custody of all unit property. The supply officer/APO will ensure that all supply actions are recorded on the appropriate forms or documents. As outlined in Chapter 5 of Volume 4 of this Order, the supply officer/APO has the authority to approve certain inventory adjustments unless otherwise directed by the CO. Supply officers/APOs will ensure the following allowance item management principles are applied:

- A. On a monthly basis, validate that allowance item information (e.g., TAMCNs, NSN/NIINs, nomenclature, authorized quantities, etc.) on the unit's TO&E is accurate and properly recorded on the unit's supply APSR.
- B. Ensure that physical inventories are conducted as required (e.g., annual, quarterly, RO turnovers, etc.) and that property records are adjusted accordingly.
- C. Track monthly serialized inventories of small arms and inform the CO when monthly inventories are not conducted. Ensure account and custody records are being adjusted accordingly, and that weapons reporting procedures are being followed in accordance with references (x) and (y).
- D. Serve as the unit RO for loans received from external commands and agencies (e.g., unit garrison personal property from the installation commander or theater-provided equipment from the theater property book office in contingency environments).

020603. Responsible Officer / Property Custodian

Unit COs with retail-level supply accounts will appoint ROs/property custodians in writing. ROs will have administrative command and/or control over all personnel using equipment assigned to them. ROs will not be assigned equipment or supplies used outside their span of control. They will ensure that the following supply management principles are applied:

- A. Receipt for all on hand equipment.
- B. Maintain assigned equipment in serviceable condition.
- C. Account for all equipment (to include all supply system responsibility items (SSRI) and SL-3) received, maintain accurate custody records within the supply APSR, and ensure all equipment is securely stored when not in-use or while in-transit and separated from the RO/property custodian.
- D. Report changes of equipment custody to the supply officer/APO on an as-occurring basis. Ensure that a new RO is appointed in writing by the CO when the RO/property custodian is separated from assets for more than 60 calendar days. The CO can waive the requirement to appoint a new RO if the property is in the possession of an appointed RI. If the assets are stored in a secure location (e.g., temporarily stored on a Maritime Prepositioning Ship), the requirement to appoint a new RO due to physical separation from the assets can be waived upon approval by DC I&L (LP).
- E. Per Volume 4 of this Order, request necessary investigative action to the CO, via the supply officer/APO, for suspected equipment abuse, gains, or losses.
- F. Conduct quarterly CMR/CAR/sub-account physical inventories of all equipment assigned to the account and reconcile the results with the supply officer. Semi-annual physical inventories may be conducted if approved in writing by the unit CO. One of the quarterly physical inventories should coincide with the command-wide annual physical inventory.
- G. When sub-signing equipment to an RI internal to the unit, ensure the RI is appointed in writing and signs for all applicable equipment.
- H. In accordance with Chapter 1 of this Volume, if an RO/property custodian elects to delegate their authority for the receipt, request, or turn-in of equipment affecting their CMR/CAR/sub-account, a NAVMC 11869 must be prepared by the RO/property custodian and forwarded to the supply officer/APO. Quarterly, NAVMC 11869s must be certified by the RO/property custodian (semi-annually if approved in writing by the unit CO). If no changes have occurred during the quarter, the RO/property custodian will certify by initialing and dating the current NAVMC 11869 on file with the supply officer/APO.
- I. Perform, validate, and ensure configuration management (parent/child relationship) by NIIN and serial number within the supply APSR for all on hand end items.
- J. Request a change of RO/property custodian from the CO and conduct a joint inventory no less than 30 calendar days prior to the date of relief. The sub-account must be transferred prior to the RO/property custodian transferring from the command.

0207 COMMAND ADJUSTMENT MANAGEMENT

Command adjustments facilitate management and provide flexibility/visibility of equipment allowances in the APSR for task-organized units and units with an approved training allowance. Command adjustments also assist in providing accurate ground equipment readiness reporting and accountability of T/E assets transferred between MAGTF organizations. All types of accountable equipment, unless otherwise specified below, are eligible for command adjustments when transferred from supporting organizations to supported organization's property records.

020701. Accountable Property System of Record (APSR)

Reference (o) establishes TFSMS as the authoritative information system for Marine Corps ground equipment AAOs and T/E allowances. Command adjustments do not change AAO/T/E allowance quantities registered within TFSMS. The APSR for ground equipment accountability (on hand quantities) is the asset management system for supply (e.g., GCSS-MC for military equipment). A command adjustment will not change the on-hand quantity, but will modify (add to or subtract from) the allowance in the ground equipment accountability APSR (e.g., Mechanized Allowance List (MAL) allowance field in the GCSS-MC).

020702. Policy

Command adjustments will not be used for correcting outdated or erroneous allowances. Command adjustments are used to capture unit requirements by exception in limited circumstances. Command adjustments are only used for military equipment. The following paragraphs outline the policy and occasions when command adjustments will be used.

A. All MARFOR and subordinate element commanders having a retail-level supply activity will adhere to this policy for managing command adjustment allowances. Guidance provided in reference (s) will be followed for readiness reporting of ground equipment to provide a consistent and accurate readiness assessment of MARFORs.

B. Command adjustments for task-organized units will be approved in writing by the first common CG in the chain of command (MARFOR, MEF, MSC, or subordinate element command).

C. Per reference (s), supporting units that transfer equipment to task-organized units will continue reporting readiness against AAO/T/E allowance quantities in TFSMS. As such, supporting units will not induct negative command adjustments for the transfer of equipment to task-organized units.

D. Task-organized units that receive equipment transfers from supporting units will report readiness against approved requirements. Accordingly, supported task-organized units will induct positive command adjustments in the supply APSR to accurately capture approved requirements for the transfer of military equipment from supporting units.

E. Per reference (s), Marine Force Reserve units with approved T/As will continue reporting readiness against T/E quantities in TFSMS. Negative command adjustments will be inducted to subtract from TFSMS allowances to establish the proper T/As within the supply APSR.

F. Command adjustments for occasions listed below are authorized for approval below the HQMC level.

1. Positive command adjustments for the formation of task-organized units with an approved EDL (e.g., MEUs, annual US-South American Allied Exercise, temporary equipment plus-up for unit deployment, SPMAGTFs, etc.).

2. Positive command adjustments for the initial formation of a permanent long-standing detachment with an approved EDL (e.g., Enhanced Equipment Allowance Pool, Combined Arms Training Center Camp Fuji, Combat Logistics Company). Per reference (r), enduring requirements in excess of one year with no known end date require long term adjustment to established allowances and will continue to be submitted via a TOECR through the requirements development process.

3. Negative command adjustments of T/E allowances to reflect authorized T/As. This applies only to reserve units.

4. Positive command adjustments for DC I&L approved special allowances.

G. Duration of Command Adjustments

1. Command adjustments will not be authorized for less than 120 calendar days. Short-term commitments of equipment must be executed utilizing temporary loan procedures outlined in Chapter 4 of this Volume.

2. Unless a permanent redistribution is directed by higher headquarters, command adjusted items will be returned to the owning command upon termination of the command adjustment. Command adjustments will end upon any of the conditions listed below.

a. One year from the authorization date. Authorization can be extended by the original approval authority.

b. The task-organized mission is complete and the unit is standing down.

c. The supported unit or higher headquarters identifies that the assets are no longer required to support the mission and/or directs redistribution by higher headquarters.

d. Equipment is replaced at the supported unit by a different TAMCN (e.g., an obsolete item is replaced by a newly-fielded item).

e. Expiration of a DC I&L-approved special allowance or conversion to T/E allowance (i.e., TOECR was approved and allowance was increased).

0208 REMAIN-BEHIND EQUIPMENT

Per reference (z), Remain-Behind Equipment (RBE) is unit equipment left by deploying forces at their bases when they deploy. Reference (aa) further defines and establishes policy for RBE when units deploy as part of a MAGTF using prepositioned equipment. All unit equipment not deployed forward will continue to be accounted for in accordance with this policy. COs deploying forward shall be formally relieved of their AO responsibilities for the RBE. The outgoing AO will provide a Certificate of Relief reporting the status of supply operations to the interim AO in accordance with Chapter 1 of this Volume. For military equipment, the MEF or MARFOR will designate what organizations will account for RBE and provide oversight. For garrison personal property and GME, the installation commander will designate what organizations will account for RBE and provide oversight.

0209 SMALL ARMS/LIGHT WEAPONS (SA/LW) CONTROL

020901. Per this policy, COs of retail-level supply activities will account for small arms. Per reference (y), the CO will report all small arms to the Naval Surface Warfare Center (NSWC) Crane, Indiana. Additionally, per references (d) and (w), the CO will maintain 100 percent inventory accuracy and accountability for small arms.

020902. The CO will appoint in writing an inventory officer (other than the supply officer, appointed armory RO, or supply/armory personnel) to conduct the monthly serialized inventory (MSI) of small arms. In addition to using current CMR records, retail activities will download current asset information and incoming and outgoing shipments reports from the NSWC Crane website to facilitate the MSI. All inventory discrepancies will be identified and researched. Per references (x) and (y) units will report all missing, lost, stolen or recovered weapons to NSWC Crane. The appointed inventory officer will sign the MSI, submit results to the CO via the supply officer, and provide a copy to the appropriate RO(s). Within five working days, the supply officer will endorse the letter to the CO noting causative research results and recommended actions to be taken for all identified discrepancies. Within five working days after receiving the supply officer's endorsement, the CO will endorse the MSI and provide the supply officer with the endorsement or appoint an investigating officer. MSIs will be completed and endorsed by the CO within the month the inventory is conducted.

020903. Display small arms light weapons (SA/LW) are defined as old or obsolete assets with unit historical significance, approved for display at individual units and accounted for in DPAS. The installation commander has the overall responsibility for ensuring that display/inert SA/LW are properly maintained, safeguarded, accounted for and accurately reported to the Marine Corps serialized SA/LW registry at NSWC Crane.

0210 RETENTION OF RECORDS

021001. Federal law requires the Marine Corps to maintain an active records management program that provides accurate and efficient tracking and retrieval of command records. Command records shall adequately document the organization, operations, functions, policies, procedures, decisions, and transactions of the Marine Corps at all levels and provide information necessary to protect the legal and financial rights of persons, commands, and the government.

A. Record

A record is defined as the information, regardless of medium, that details business transactions. Records include all books, papers, maps, photographs, machine-readable materials, and other documentary materials, regardless of physical form or characteristics. Records are made or received by an agency of the United States Government under federal law or in connection with the transaction of public business.

B. Electronic Record

The information recorded in a form that requires a computer or other machine to process it and that satisfies the definition of a record. Reference (ab) provides guidelines for electronic record management.

021002. Per Volume 5 (Disbursing Policy) of reference (e), original disbursing office records and associated papers and supporting documentation must be retained for ten years, consistent with guidance in reference (ac). As a result, all supply records (e.g., proof of delivery, voucher files, and supply appointment letters) will be maintained in an active file for a period of three years and then in an archive file for a period of seven years. In total, the retention of supply records is ten years.

A. Voucher Files

Voucher files include all records relating to the gain, loss, return, disposal, or transfer of property. Supporting documentation includes, but is not limited to: recoverable items reports, letters of unserviceable property, Money Value Gain Loss Notices, cash collection vouchers, investigations, inventory result/certification letters, Missing Lost Stolen or Recovered (MLSR) reports, and Supply Discrepancy Reports (SDR). In addition, voucher files include financial account records that directly or indirectly result in a recordable accounting transaction (i.e., initiation, commitment, obligation, expense, and liquidation).

B. Appointment Letters

Applicable supply appointment letters are discussed in Chapter 1 of this Volume. Appointment letters include associated DD 577s and the CO and supply officer/APO Certificate of Relief letters (see Appendices G and H). Per Volume 5 (Disbursing Policy) of reference (e), retain copies of DD 577 for ten years (i.e., three years active and seven years archive) after appointment termination.

C. Supply Active File

The supply active file is the storage of supply records (hard-copy or electronic) that documents three years of an organization's daily operations. The active file will be maintained to allow for immediate record recovery to support daily operations and auditability.

D. Supply Archive File

The supply archive file is the storage of supply records (hard-copy or electronic) that documents seven years subsequent to the supply active file for a total of ten years of documentation. The supply archive file is maintained to meet federal law requirements and to meet potential future audit requests. Unlike the supply active file, the supply archive file will be maintained to facilitate record recovery vice allow for immediate record recovery.

021003. Time-Event Disposition

Supply record retention is based on time-event disposition. Time-event disposition specifies that a record shall be disposed of at a fixed period of time after a specified event. Once the specified event has occurred, then the retention period is applied (e.g., induction of a transfer transaction, appointment revocation, etc.).

0211 UNSERVICEABLE ASSETS

021101. Each unit CO will maintain all on hand items as serviceable and ready-for-issue. Do not commingle unserviceable materiel with serviceable materiel in storage locations. Procedures for handling and accounting for unserviceable assets are detailed in this Volume and the User's Manual 4400-125, "Retail Supply and Maintenance Execution Procedures." Use the applicable TM/TI, when available, to determine materiel serviceability.

A. Unserviceable military equipment requiring disposition instructions will be maintained in a manner to prevent further deterioration until disposition instructions are provided. Upon direction from the intermediate maintenance activity, for unserviceable military equipment, units will request disposition instructions from MARCORLOGCOM. Upon direction from Facilities Engineering, for unserviceable garrison property or GME, units will request disposition instructions from MCICOM.

B. All other unserviceable assets shall be disposed of directly through the DLA – Disposition Services in accordance with Volume 3 of reference (i) and Volume 6 of this Order.

021102. All disposal transactions require a transaction voucher to maintain an audit trail.

0212 EXCESSES

Retail-level supply accounts are not authorized to retain excess materiel. COs will guard against having materiel in excess of established authorized quantities. Per the guidance in reference (ad), quantities of items on hand greater than authorized levels must be redistributed, returned, disposed of, or canceled.

0213 DEMAND-SUPPORTED ITEMS

021301. Definition

Demand-supported items (DSI) are quantities of expendable and nonexpendable items which are on hand based on supported or limited stockage criteria and are authorized to support mission requirements. DSI typically, but not exclusively, consists of Class IX repair parts. DSI can also consist of garrison property and real property. Examples of DSI include:

- A. Commonly used hardware items such as nuts, bolts, and battery terminals.
- B. Items used during scheduled preventive maintenance such as filters, belts, and hoses.
- C. High usage items that affect readiness of a unit such as voltage regulators, weapons parts, and radio handsets.

021302. Purpose

The primary purpose for maintaining DSI is to place fast moving, low-cost items (i.e., less than or equal to \$500 per unit of issue (U/I)) at the same location as the customer who requires them. Stocking these items at the maintenance commodity allows an expedited return of critical assets to an operational status. COs must monitor DSI usage to ensure that only required items are stocked and to prevent these items from becoming an undue logistical burden.

021303. Demand-Supported Stockage Criteria

Retail-level supply organizations may maintain DSI as long as all of the following requirements are met:

- A. Approval is provided in writing by the unit CO on an annual basis.
 - 1. The supply officer will coordinate with the maintenance management officer (MMO) to formally request demand-supported stockage levels by NSN to the CO.
 - 2. Prior to routing the request to the CO for approval, all requests will be reviewed by the appropriate supporting SMU for endorsement (MSC G-4 if not supported by a SMU). The SMU's endorsement will not dictate final stockage levels, rather it is their recommendations based on existing inventory levels and analysis of past demand history. SMU input will be provided as an endorsement to the annual formal request to the CO.

3. If an enclosure is used to list the DSI, the CO must initial each page of the enclosure.

4. Once approved, the supply officer and MMO will review the demand-supported stockage listing quarterly to ensure the expenditure of funds is consistent with the needs of the unit. Periodic reviews during the year must be conducted to ensure that demand-supported stockage levels are maintained at the appropriate range and depth. COs may approve changes to the annual listing based on quarterly reviews without SMU endorsement; however, this does not preclude the requirement for the SMU review on an annual basis.

B. Usage history (issues) is sufficient to justify maintaining readily available stocks on hand. The usage history must be as follows:

1. For those items applied/consumed as a full U/I, the usage history is six U/I's applied/consumed in 12 months.

2. For those items applied/consumed as less than a full U/I (e.g., roll, hundred, or box) the usage history is one U/I applied/consumed in 12 months.

C. Stocks are consistent with a unit's funding, embarkation capability, and maintenance requirements.

D. On a quarterly basis, DSI stocked using the above criteria must be reviewed and adjusted, if required. Once an item is eligible, stock levels will consist of the following elements:

1. Reorder Quantity. The reorder quantity determines the amount of supplies that are reordered when the inventory position (i.e., on-hand plus due-in minus due-out) falls at below the Reorder Point (ROP). The reorder quantity will not exceed a 30-day usage requirement for each individual item.

2. Reorder Point (ROP) / Minimum. The ROP is the inventory quantity on hand that triggers the purchase of a predetermined amount of replenishment inventory (i.e., Reorder Quantity). The ROP consists of the average daily usage during replenishment lead time plus the safety level. Replenishment lead time is the total period of time that elapses from the time an item is ordered until the item is received. Retail activities below the intermediate level (e.g., SMU, RIP, or CLB) will not exceed a 35-day ROP (i.e., 5 days + 30-day safety level) for Combat Essentiality Code (CEC) "5" and "6" items or 20-day ROP for 15 days (i.e., 5 days + 15-day safety level) for CECs other than "5" or "6." Intermediate-level retail activities will use Time Definite Delivery standards as the basis for calculating the ROP. Time Definite Delivery standards are available at [Office of Deputy Assistant Secretary of Defense \(OSD\) for Supply Chain Integration](#). When historical data indicates that actual replenishment lead time is routinely greater than the Time Definite Delivery standards, intermediate-level retail activities can use the historical data to calculate the ROP. For additional policy and guidance pertaining intermediate-level inventory management, refer to Volume 8 of this Order.

13 JUN 2016

3. Safety Level (SL). The safety level (SL) is the quantity of materiel required to be on hand to permit continued operation in the event of a minor interruption of normal replenishment or a fluctuation in demand. The SL will not exceed 30 days for CEC “5” and “6” items or 15 days for CECs other than “5” or “6.”

4. Maintenance, Repair, and Operations (MRO). This consists of operating stock at the supporting establishment/installation that supports the maintenance of real property. The MRO will not exceed 30 days for critical items or 15 days for non-critical items.

021304. Customer Wait Time (CWT)

CWT is the total elapsed time between issuance of a customer order and satisfaction of the order. CWT is the portion of the total OL quantity which covers the CWT replenishment requisitions.

021305. Minimum/ Maximum (Min/Max)

Min/Max levels are established by the CO to support maintenance requirements. The Min represents the minimum quantity to be maintained on hand to sustain operations. This Min consists of the ROP as defined in paragraph 021303.D.2. The Max represents the maximum quantity authorized by the CO to be maintained on hand to sustain operations. The Max consists of the ROP (as defined in paragraph 021303.D.2) plus the Reorder Quantity (as defined in paragraph 021303.D.1).

021306. Broken Unit of Issue

A. Broken U/Is of common hardware (e.g., bolts, nuts, screws, or washers) costing less than or equal to \$5 per U/I that are ordered against a corrective maintenance service request and do not meet demand-supported stockage criteria do not require further control or accounting once the U/I is applied to the equipment. The leftover portion will be displayed in a parts bin, in plain view of the shop’s maintenance personnel, and used until exhausted. Strict control and accountability is not required, but maintenance supervisors must ensure mechanics/technicians use the on hand supply before ordering more.

B. Broken U/Is not considered common hardware or costing more than \$5 per U/I will be added to the authorized demand-supported stockage listing. They must be identified on the list as broken U/Is and reflect the date they were added to the list. They may be retained as a demand-supported stockage item until exhausted.

021307. Inventory adjustments to demand-supported inventory will be executed in accordance with Volume 4 of this Order.

0214 STOCK LIST-3 (SL-3) COMPONENTS LIST

021401. The SL-3 lists all components of collection-type items (e.g., chests, sets, kits, outfits, and assortments) and components of military equipment (e.g., vehicles, weapons, and communications equipment).

021402. The SL-3 is divided into three categories: Supply System Responsibility Items (SSRI), Using Unit Responsibility Items (UURI), and Collateral Materiel (CM).

A. Supply System Responsibility Items (SSRI)

Items listed under this category are normally fielded when the associated parent ME is fielded, however, SSRI may be integrated at any time in order to provide the capability set. SSRI is transferred with the end item during redistribution or other changes of custody unless otherwise directed by MARCORLOGCOM. SSRI can be TAMCN, non-TAMCN items, and Operating Materiel and Supplies (OM&S). SSRI that have a TAMCN will have its own SL-3 instead of having the components listed individually in the Parent TAMCN's SL-3. If SSRI are serially managed items, they will be uniquely identified separately as embedded items (children) in the parent item within the APSR. SSRI items are required to be maintained on hand, on order, or identified as an unfunded deficiency unless otherwise directed within the SL-3 or as specified in paragraph 020502. All SSRI will have a stated quantity. Requisitioning replacement SSRI (SAC 1 and non-TAMCN items) is the responsibility of the owning unit after initial fielding. For replacement of SAC 3 SSRI, the owning unit will request replacement from MARCORLOGCOM via the unit's chain of command. Within TFSMS, SSRI are identified with an 8-digit TAMCN and are "Part Of" a 7-digit Parent TAMCN. Similarly, the 7-digit Parent TAMCN "Consists Of" the 8-digit SSRI TAMCN. Allowances for SSRI TAMCNs are identified in the "Component TAMCN" section of a unit's TO&E.

B. Using Unit Responsibility Items (UURI)

Items listed under this category are not issued with the end item when an end item is fielded. Items in this category must be requisitioned by the unit (not to exceed the SL-3's stated quantity for non-TAMCN items or T/E requirement for SAC 1 items) via the supply system or sourced (not to exceed the T/E requirement for SAC 3 items) via the push fulfillment process. UURI can be TAMCN, non-TAMCN items, or OM&S. Individual components of UURI that have a TAMCN will not be individually listed in the associated TAMCN's SL-3. UURI that are identified as having a Type 1 or Type 2 TAMCN will be validated against the unit's T/E requirements, UURI will be accounted for on property records. UURI remains with the owning unit and is not transferred with an end item during redistribution/rebuild or other changes in custody. An exception would be a directed redistribution because of force modernization, retrograde, or a unique requirement where the UURI is not needed by the owning unit, but may be of use with the associated end item. The CO can authorize, in writing, to hold less than the SL-3's stated quantity if the item does not meet the criteria in paragraphs 021402.B.1 and 021402.B.2. Additionally, where "AR" (as required) is the SL-3's stated quantity (for non-TAMCN items), the commander must establish, in writing, the authorized quantity to be held by the command. These quantities will be reviewed and updated at least annually. Within TFSMS, UURI is identified with a 7-digit TAMCN that is "Used By" or "Used With" another 7-digit TAMCN.

1. UURI Type 1 TAMCN. DC CD&I (TFSD) and MARCORSYSCOM will ensure UURI Type 1 TAMCN requirements are established or adjusted within unit T/Es. New T/E requirements for UURI Type 1 TAMCN items will be published in the Fielding Plan of the associated end item. Policy for UURIs to support cadre units, reserve initial issue, and active forces WRMR is contained in reference (aa). For additional guidance pertaining to Type 1 items, refer to paragraph 020502 of this chapter.

2. UURI Type 2 TAMCN. For Type 2 items, refer to paragraph 020503 of this chapter for guidance on establishing requirements.

C. Collateral Materiel (CM)

Items listed under this category are non-TAMCN items or OM&S furnished with end items upon initial issue and normally remain with the owning unit during redistribution/rebuild or other change of custody unless otherwise directed by MARCORLOGCOM CM is support items that facilitate the maintenance of an end item (e.g., batteries, electrical tape, paint brushes, and etc.). These items must be maintained on hand, on order, or identified as an unfunded deficiency unless otherwise directed within the SL-3. Items under this category will be requisitioned by the individual NSN/NIIN and/or part number and CAGE Codes. With the exception of materiel with a 9999-series NSN, CM will be maintained and replaced by the owning unit. Owning units are not authorized to requisition items that have a 9999-series NSN. A 9999-series NSN shown under the heading of "Collateral Materiel" is for control within the distribution system only and is not authorized for requisitioning purposes.

D. Ammunition

Ammunition is listed in the SL-3/TM for clarification only. Refer to Volume 7 of this Order for more information.

E. Small Arms/Light Weapons (SA/LW)

SA/LW (as defined in reference (y)) that are SL-3/TM components will have requirements established on unit T/Es. MARCORSYSCOM will establish these requirements for newly fielded items. The owning unit CO is responsible for reviewing and recommending adjustments to T/E requirements for fielded items.

F. Associated Expendables

Expendable items used with end items are often listed for informational purposes in SL-3s, TMs, and other component listings. Associated expendable items may be procured and held by retail-level activities in limited quantities on an "as required" basis and do not require stockage levels in writing.

021403. When SL-3 components received through the supply system to replace missing or unserviceable items do not match the exact descriptive data of the stocklist, units are authorized to maintain those items if the item received meets the "form," "fit," and "function" of the SL-3 component. This includes purchases from commercial vendors.

021404. Items listed as CM must be on hand or on order at all times. SSRI items are required to be maintained on hand, on order, or identified as an unfunded deficiency unless otherwise directed within the SL-3 or as specified in paragraph 020502. Training aids at formal Marine Corps schools are the only exception to this rule. The CO/director of the school will designate in writing (by end item) the quantity of SSRI and CM to be maintained for end items used as training aids.

021405. Detailed instructions for SL-3/TM inventory and recordkeeping requirements are contained in reference (ae). Specified procedures apply to all SL-3/TM inventories.

021406. Batch SL-3 Inventories

The batch SL-3 inventory method involves counting all individual items within an SL-3 as one complete set rather than as individual items. Initially, all individual items are inventoried and subsequently batched together as a complete set. Afterwards, the batch SL-3 is counted as a complete set unless the individual items are removed from the set for use. Batch SL-3 inventories are appropriate for certain types of end items to reduce the administrative burden associated with performing individual SL-3 inventories for numerous items especially when the individual items or the set is not commonly used. If ground equipment requires SL-3 items to be fully operational (e.g., tent requires stakes, line, and etc. to be properly erected), then each end item must have an individual SL-3 inventory performed and documented. If the end item is fully operational and ready for use without its associated SL-3 items (e.g., weapon can fire without cleaning gear, vehicle can drive without pioneer tools or gas/water cans), the associated SL-3 items may be accounted for using the batch inventory method. Class II organizational property items in the supply warehouse which require periodic SL-3 inventories, with the exception of ICCE, must have individual SL-3 inventories documented for each end item. One record jacket is permitted, but an SL-3 inventory sheet for each end item is required.

0215 GARRISON PROPERTY

Per reference (af), garrison property is used to provide general government services or goods in the support of end item development, maintenance, storage, and/or to support the operations of a Marine Corps installation and its tenant activities. Garrison property includes, but is not limited to: office equipment, industrial plant equipment, automated data processing equipment, training and audiovisual equipment, special tools, and special test equipment. The Marine Corps classifies garrison property as a sub-category of general equipment. Garrison property does not include: inventory items (e.g., items intended for sale), OM&S, real property (i.e., land, buildings, and structures, or items of a historical nature), or military equipment (i.e., TAMCN items). Garrison property does not deploy.

021501. Commands that own, loan, lease, or are responsible for garrison property shall maintain accountability for such items in accordance with reference (af), and Volume 4 of this Order.

021502. For the transfer of all accounts prior to unit deployments or rotations, COs (the AO) with garrison property accounts or sub-accounts will ensure that inventories are conducted and account discrepancies are addressed prior to the unit's departure.

021503. Due to the organizational structure of most bases, posts and stations, the logistics officer or supply officer may be tasked to perform functions the CO normally accomplishes (i.e., vouchering, priority approval, review requests for investigations, and turnover letters); however, per reference (af), the CO remains the AO for garrison equipment. Upon change of command, the logistics officer or supply officer will prepare a certificate of relief and continually provide the CG or CO with the status of the supply account.

0216 GARRISON TOOL ALLOWANCES

Retail-level COs (not below the battalion/squadron level except for detached units) are authorized to establish special tool allowances in writing for tools required to meet garrison-peculiar requirements and are not currently maintained within TO&E sets, kits, and chests. This includes locally fabricated tools. With the exception of locally fabricated tools (as directed by a technical publication or Acquisition Advice Code), garrison tool allowances will not exceed \$50 in extended value.

021601. Garrison-specific tools are defined as tools needed to support requirements that would not exist in a deployed situation. Tools required for conducting authorized levels of maintenance on organic equipment or in support of the unit mission will be either TO&E items or components of TO&E items.

021602. Locally fabricated tools are tools whose fabrication is directed by a technical publication or Acquisition Advice Code. The authorization list for locally fabricated tools will reference the technical publication that authorizes each tool.

021603. Before submitting SL-3/Technical Manual changes, other end items and tool kits already on the unit's TO&E should be checked as a source of required tools.

0217 ELECTRONIC KEY MANAGEMENT SYSTEM EQUIPMENT

Per this Volume and reference (ag), EKMS equipment will be accounted for in both the Marine Corps ground equipment APSR (e.g., GCSS-MC) and the Department of the Navy's Naval Communications Security Material System. The EKMS custodian is responsible for the requisitioning and disposition of controlled cryptographic equipment. The EKMS custodian and the supply officer must communicate regarding all adjustments to the EKMS account and provide each other with the necessary supporting documentation (e.g., DD 1348, "DoD Single Line Item Requisition System Document (Manual)," DD 1149, "Requisition and Invoice/Shipping Document," SF-153, "COMSEC Material Report") that affects the unit's accountable records.

0218 SERIALIZED ITEMS

MARCORLOGCOM, MCICOM, program executive officers, program managers, and product managers use the following attributes to ensure the registry of items and NIINs that require serialized management.

021801. Marine Corps SAC "3"

All SAC 3 military equipment shall be serially managed.

021802. Marine Corps Controlled Item Code "A"

All Type 1 cataloged Marine Corps items identified with CIC A requiring special control shall be serially managed.

021803. Source, Maintenance, and Recoverability Code

As required by reference (h) NIINs with a Source, Maintenance, and Recoverability Code of “D,” “F,” “H,” and “L” will be serially managed.

021804. Marine Corps Operational Test Code “3”

The Marine Corps catalogs and uses Operational Test Codes (OTCs) to identify items of supply that require special procedures to be performed during care-in-stores or during the issue process. These special procedures are in addition to normal care-in-stores, shelf life (to include Lot numbers), and electrostatic discharge handling procedures. Upon issue from Condition Code A (serviceable, ready for issue) stocks, OTCs ensure the item’s quality and that the item performs its intended function(s). OTC 3 items require established calibration procedures (e.g., electronic test equipment, meters, gauges, torque wrenches, etc.) whether technical or non-technical in nature. Therefore, OTC 3 items will be serially managed.

021805. Sets, Kits, Outfits, and Tools

Sets, kits, outfits and tools (SKOTs) are assemblages of components, support items, and common tools in a container (bag, pouch, box, chest, van, trailer or shelter) that are designed to accomplish a specific mission or maintenance function. SKOTs are identified, cataloged, authorized, and issued as a single unit. They may consist of: components, support items, and tools included in more than one class of supply; end items; and nonexpendable, durable, and expendable components. A SKOT is an item of supply where the configuration is controlled by a TAMCN, NSN, or NIIN.

A. If a SKOT meets the qualifying criteria provided in this directive and resides in the Marine Corps inventory, then a SKOT will be serially managed. If any of the components of the SKOT are serially managed items, then the components will be uniquely identified separately as embedded items (i.e., child components of the parent item). Refer to Chapter 2 in this Volume for the management of non-serialized SKOT components (i.e., SL-3 Components Lists).

B. COs will properly account for serially managed embedded (child) components as configurations in the GCSS-MC Installed Base module.

C. A SKOT may consist of components for a single assembly part, or components packaged together as a single TAMCN where no centralized military equipment (parent) contains the system’s serial number. For example, the Army Navy/Vehicle Radio Communications (AN/VRC) consists of multiple radio transmitters and multiple radio amplifiers that are each serially managed; however, there is no parent serial number. In these situations, the parent serial number will be captured in GCSS-MC as follows:

1. For legacy SKOT items, “unique serial numbers” will be created using the owning unit’s property control DoDAAC, minus the service code, and three additional numbers (e.g., 12001001). The unique serial number will transition into GCSS-MC and endure for the lifecycle of the SKOT.

2. A GCSS-MC serial number will be assigned to all newly fielded SKOT Parent TAMCN/NIINs that require serialization.

13 JUN 2016

3. Once assigned, the SKOT serial number will be placed on a data plate that may be retained and reapplied when the major component to which it is affixed is replaced.

4. When equipment is transferred between units, serial numbers will remain as-is. Until MARCORLOGCOM and MARCORSYSCOM publish permanent serial numbers or UII and data plate placement instructions, legacy and GCSS-MC assigned serial numbers will remain on the parent TAMCN and NIIN.

D. A SKOT containing 65 percent or more serviceable components are considered serviceable. A SKOT containing less than 65 percent serviceable components are considered unserviceable. For an unserviceable SKOT, units will requisition missing or unserviceable components or identify as an unfunded deficiency.

E. SKOTs that are not issued and are securely stored will be inventoried annually. SKOTs that are issued and used by the same individual where locks and a secure storage area are provided will be inventoried at least quarterly. All other SKOTs will be inventoried on a monthly basis.

021806. Controlled Inventory Item Code (CIIC)

A CIIC is a one-position cataloged code that indicates the security classification and/or security risk or pilferage controls for storage or transportation an item. If the Marine Corps is registered in DLIS as the PICA, the Secondary Inventory Control Activity, or a NIIN registered user, then the Marine Corps will serially manage items or NIINs that have any of the following CIICs assigned. If a CIIC is improperly assigned to an item, then submit a Cataloging Action Request to MARCORLOGCOM to fix the discrepancy in accordance with reference (ah). Refer to Table 61 in Volume 10 of reference (m) for additional descriptions of the CIICs in paragraphs 021807, 021808, and 021809.

021807. Classified Items Code

A cataloged code that indicates the materiel requires protection in the interest of national security. Per Table 61 of reference (m), the following codes apply:

- A. "A" Confidential - formerly restricted data
- B. "B" Confidential - restricted data
- C. "D" Confidential - cryptologic
- D. "E" Secret - cryptologic
- E. "F" Top Secret - cryptologic
- F. "G" Secret - formerly restricted data
- G. "H" Secret - restricted data

- H. “K” Top Secret - formerly restricted data
 - I. “L” Top Secret - restricted data
 - J. “O” Caution - store and handle in a manner that will prevent unauthorized access to this materiel
 - K. “7” Items assigned a Demilitarization Code other than A, B, Q or P for which another CIIC is inappropriate in accordance with reference (m). Note: The loss, theft, unlawful disposition, or recovery of an item with CIIC 7 must be investigated in accordance with Volume 4 of this Order.
 - L. “9” Controlled Cryptographic Item
021808. Sensitive Items Code

Sensitive Item Codes identify materiel that requires a high degree of protection and control due to statutory requirements or regulations, such as: narcotics and drug abuse items; precious metals; items which are of high value, highly technical or of a hazardous nature; and arms, ammunition, and explosives (AA&E) and demolition materiel. Items with a Sensitive Item Code will be serially managed. Per Table 61 of reference (m) the following codes apply:

- A. “1” Highest Sensitivity (Security Risk Category (SRC) I) - Cataloged Unclassified AA&E. Man portable missiles and rockets in a ready-to-fire configuration. Included are the Redeye, Stinger, Javelin, light antitank (LAW) (66mm), shoulder-launched and cartridge (84 mm). These weapons, when jointly stored or transported with the launch tube or grip stock and the explosive round, though not in a ready-to-fire configuration, shall be considered Category I items.
- B. “2” High Sensitivity (SRC II) - Unclassified AA&E
- C. “3” Moderate Sensitivity (SRC III) - Unclassified AA&E
- D. “4” Low Sensitivity (SRC IV) - Unclassified AA&E
- E. “5” Highest Sensitivity (SRC I) - Secret AA&E
- F. “6” Highest Sensitivity (SRC I) - Confidential AA&E
- G. “7” Non-Sensitive (SRC-N/A) - Unclassified AA&E
- H. “8” High Sensitivity (SRC II) - Confidential AA&E
- I. “C” Moderate Sensitivity (SRC III) and Low Sensitivity (SRC IV) - Confidential AA&E.

021809. Pilferage Code

This code indicates the materiel has a ready resale value or civilian application for personal possession and, therefore, is especially subject to theft. Pursuant to reference (w) all pilferage code "J" items shall be serially managed. Refer to Table 61 of reference (m) for additional pilferage codes.

021810. Classes of Supply

A. Class I

Consumable subsistence supplies will not be serially managed.

B. Class II

Clothing, expendable individual equipment, consumable administrative and housekeeping supplies will not be serially managed.

C. Class III(p)

Petroleum, oils, and lubricants will not be serially managed.

D. Class IV

Barrier and construction materials will not be serially managed.

E. Class V

021808. Ammunition and Explosives will be serially managed in accordance with paragraph

F. Class VI

Personal demand items will not be serially managed.

G. Class VII

Major End Items will be serially managed per paragraph 0218.

H. Class VIII

Consumable medical supplies will not be serially managed.

I. Class IX

Unless cataloged with an OTC of 3, consumable repair parts and components with a recoverability code of "Z" and "O," will not be serially managed.

VOLUME 3: CHAPTER 3

“WAREHOUSING”

SUMMARY OF SUBSTANTIVE CHANGES

All changes are denoted by **blue font** unless a full revision has been conducted.

Substantive revisions are denoted by a * symbol preceding the section, paragraph, table, or figure that includes the revision.

Hyperlinks are denoted by ***bold, italic, blue and underlined font***.

Base date of this Marine Corps Order (MCO) Volume (right header) will not change unless a full revision has been conducted. Upon full revision of this Volume, all changes denoted by blue font will reset to black font.

PAGE PARAGRAPH	EXPLANATION OF SUBSTANTIVE CHANGES	PURPOSE	DATE OF CHANGE

CHAPTER 3

WAREHOUSING

0301 RETAIL WAREHOUSING

As stated in reference (d), warehouse management consists of planning, organizing, directing, coordinating, controlling and evaluating the maximum utilization of storage and warehousing facilities to provide effective and economical use of space to house material in support of military forces. This chapter promulgates policy and assigns responsibilities for the management and execution of the Marine Corps Warehouse Program at retail-level organizations. The instructions contained herein provide procedures to be followed in establishing, using, expanding, inactivating, and disestablishing storage and warehousing operations and facilities; cross-servicing of warehousing by and among DoD components, and between DoD components and Federal Government agencies; assuring the most effective, economical use of storage assets; and proper inventory procedures of materiel and supplies within the Marine Corps. Understanding and execution of these warehouse policies are essential for effective materiel management required to ensure mission accomplishment.

0302 RETAIL STORAGE PROCEDURES

030201. General Information

Storage activities have physical custody of supplies and are responsible for accounting, caring and safeguarding it. This paragraph establishes uniform storage and materials handling policies, procedures, and responsibilities for use by the DoD supply activities involved in the receipt, storage, issue and care of military supplies and equipment, except for preservation/packing; maintenance of bulk petroleum fuel handling facilities, and hazardous materials storage. Regardless of what is stored, the basic storage principles apply.

030202. Storage Activity Responsibility

The responsibilities of the storage activity are:

A. The storage activity is responsible for the accuracy, condition and changes of the inventory held under its control.

B. The storage activity maintains the property accountability record for all materiel in storage and is responsible, as a minimum, for: materiel custody, care, receipt, storage, and issue; safeguarding, and re-warehousing materiel; physical inventory, and research; location survey/reconciliation; quality control checks; SDR initiation and tracking, research and resolution; investigating and assessing financial liability for loss, damage, and destruction of government property; and appropriate actions necessary to ensure that the physical on-hand quantity and the total item property record quantity are in agreement.

C. Storage inventory systems shall support perpetual inventories where current item record balances are maintained. Storage inventory systems will post all balance and transactions affecting events such as the receipts, issues, inventory adjustments, condition changes,

ownership changes, or location changes as they occur. If a storage activity's system cannot currently support perpetual balances, the storage activity system's program management office will make efforts to bring the system into compliance with reference (d). The warehouse supervisor will identify storage inventory system deficiencies and program requirements to the program management office via the respective chain of command.

D. The record or record set shall identify the quantity, condition, and value of the supplies for each organizational entity having physical custody of those supplies. When feasible, item records will satisfy applicable UII requirements as stated in reference (ai).

E. Storage inventory systems will provide visibility of supplies while: in-transit, in-storage, in-process, or in repair.

030203. Storage Activity Functions

The core functions of a storage activity are receiving, care of supplies in storage (COSIS), materiel release (issue), shipping, and inventory control.

030204. Identification

The Marine Corps uses the NSN (see paragraph 020202) to identify items. The NSN can be used in conjunction with other item identifiers such as the UII (see paragraph 020207) or serial number to further identify an individual item. A MCSN (see paragraph 020204) can be assigned to a rapidly acquired and fielded item for Marine Corps use.

030205. Receiving

Receiving consists of: all actions taken by a receiving activity to physically accept materiel from a carrier (or consumer in the case of a return). Receiving occurs until the on-hand balance of the accountable stock record file or in-process receipt file is updated to reflect the received materiel as an asset in storage or the materiel as an issue directly from receiving.

A. Materiel Due-In

Materiel Due-in involves the transmittal of information about incoming materiel between Inventory Control Points (ICPs) and storage activities. Due-in transactions are used to establish and cancel due-in records and transmit due-in establishment and cancellation actions. The ICP shall transmit advance notification of scheduled materiel receipts to maintenance and storage activities. Units shall establish due-in records to maintain property accountability and visibility of materiel due-in to inventory. Reference (ax) provides further guidance.

B. Prompt and accurate processing of receipts is a prime requisite of an effective supply system. The types of supplies to be handled, distance to the storage location, type of Military Handling Equipment (MHE) available, and the physical characteristics of the storage installation influence receiving operations.

13 JUN 2016

C. Although the basic principles of receiving are universally applicable wherever supplies are received for storage and subsequent distribution, the receipts of classified, pilferable, and sensitive items (including small arms) require special handling and controls over and above the basic receiving principles.

1. Within 24 hours (except for holidays and weekends), record supply receipts and make supply records visible from the point of inspection and/or acceptance.

2. Verify the information on the DD 1348-1A, "Issue Release/Receipt Document" or DD 1348-2, "Issue Release/Receipt Document with Address Label" to ensure that the supporting documentation matches the physical materiel received. Verify the ship-to address, NSN, quantity ordered, quantity received, description, condition code, and serial number (if applicable).

3. Inspect lot-controlled and shelf-life materiel for appropriate condition and type of shelf-life code in accordance with reference (aj).

4. Identify, account for, secure, and segregate in such a manner that ensures protection and integrity of sensitive inventory items coded with Physical Security/Pilferage Codes R and Q and items with a Hazardous Characteristics Code of A1. Implement procedures to ensure that sensitive materiel is not received and issued without utilization of operations codes.

5. When shipments of materiel are received from commercial sources that require inspection and/or acceptance at destination, accomplish the inspection and/or acceptance and check-in operations concurrently.

6. When materiel has been received, respond with a proper materiel receipt acknowledgement transaction in accordance with reference (ak).

7. In addition to processing and reporting materiel receipts, submit reports for all discrepant and/or deficient receipts.

8. Integrate packaging or repacking operations (if necessary) with overall movement actions to reduce handling. This should occur before the final storage area.

9. Properly mark materiel prior to movement to storage to ensure accurate stock accounting, issues, and inventory actions.

10. Mark all materiel or containers containing materiel (excluding small items of retail stock) in accordance with reference (al). Discrepant or deficient receipts from the SMU to end user do not require submission of a discrepancy report.

030206. Materiel Storage

Materiel storage is the movement of supplies to a storage location involves the unloading and receiving processing actions. The following policy applies:

13 JUN 2016

- A. Move materiel via the most expeditious and economical means available.
- B. Clearly mark materiel with the NSN/NIIN, quantity, and destination.
- C. Use conveyors, MHE, or in-floor tow systems for short distances.
- D. When conveyor or in-floor tow systems are not available, use a forklift truck for short distance movements (i.e., less than 400 ft each way) and a tractor-trailer train or truck for larger distances (over 400 ft), difficult terrain, or excessively heavy material.

030207. Stock Locator

Stock location systems must pinpoint an exact storage location in a simple, easily understood manner. This is necessary to: minimize training requirements; assist in timely and accurate storage or selection of stock; and optimize utilization of storage space.

- A. Stock location systems will make optimum use of mechanized processing equipment, communications systems, and automatic data processing equipment.
- B. Planning for storage locations for classified, sensitive, and/or pilferable items will include coordination with the Security Officer/Provost Marshal Office.

030208. Care of Supplies in Storage (COSIS)

Establish a COSIS program to ensure the maintenance of materiel in storage is in a ready-for-issue condition and prevent deterioration of unserviceable materiel. Storage activities are responsible for providing protection from the elements and environmental conditions by providing proper storage facilities, preservation, packing, marking, or a combination of those measures. Conduct COSIS in accordance with reference (am) and include the following:

- A. A quality assurance program for inspection and/or test.
- B. A system for reporting and recording of quality assurance data.
- C. Provisions for the entry of the condition of materiel into the total item property record.
- D. A system to ensure that corrective actions for deficiencies uncovered during inspections are done to restore the items to serviceable condition or protect unserviceable materiel from deterioration.

030209. Materiel Release Order

An MRO is an order issued by an accountable supply system (usually an inventory control point; accountable depot or stock point) that directs a non-accountable activity (usually a storage site or materiel drop point) within the same supply distribution complex to release and ship materiel to fulfill a requisition by a customer on DD 1348-1A or DD 1348-2 continuation page. Per reference

(an), the continuation page is a mandatory document to assist the processing of serialized items. This is commonly referred to as an issue. Adhere to the following:

- A. Treat each issue as a separate action.
- B. With the exception of when the issue of newer stocks is justified by special requirements, issue the oldest materiel in storage first. Exceptions to the first-in-first-out policy are for shelf-life materiel where first-expired-first out is applicable (e.g., disposal actions). Further guidance is provided in reference (aj).
- C. Capture and provide all required data such as: the UII for DoD serially managed items; lot number; and any other pertinent information used to identify materiel.
- D. When an insufficient quantity of materiel is in stock to satisfy a directed issue, issue the available balance and transmit a materiel denial unfulfilled quantity to the accountable supply system. This is commonly referred to as a partial issue.
- E. Confirm all issues of materiel from the storage activity (including issues from receipts) to the property records within five business days through electronic communications.
- F. Using machine-readable devices improves the issue process by: facilitating detailed audit trails; validating customer authorizations; eliminating document control functions; and enabling a paperless environment.

030210. Shipping

This paragraph provides guidelines in shipping operations as they pertain to storage functions. Primarily, the guidelines are for the distribution of material from the warehouse to the distribution management office for preparation for final delivery to the customer/requisitioner. Specific shipping instructions are found in reference (ao).

- A. The provisions of this section do not apply to shipments of ammunition and other dangerous articles. Directions for the preparation and shipment of such items are contained in references (ap), (aq), and (ar).
- B. Properly document all shipments to eliminate delays, damages, or loss. Each issue (MRO) will have a DD 1348-1A or DD 1348-2 continuation page.
 - 1. Establish shipping process to consolidate MROs destined for one customer to meet required delivery times to include military shipping label with MROs and quantities.
 - 2. Use fundamental principles and approved procedures to pack military supplies and equipment for protection against damage and deterioration during shipment.
- C. Supplies requiring preservation, packing, marking, or other processing should be processed in accordance with reference (as).

D. Mark all shipments with a military shipping label that complies with DoD automated identification technology standard marks as identified in reference (al), to deliver to shipping activity.

0303 RETAIL STORAGE LAYOUT

030301. General Information

Warehousing and storage activity operations vary according to the amount and level of supply. The basic warehouse operations functions are inspecting, receiving, storing, inventorying, COSIS, issuing, and shipping of supplies.

030302. Storage categories

Warehousing is divided into four major categories of storage: carousel, bin, medium, and bulk. Such categories are based upon the popularity, physical characteristics, and stock level of supplies. The materiel being stored shall dictate the type of container used in each storage category. The storage containers shown in Appendix N are available for use.

A. Carousel Storage

Carousel Storage is endless loop monorail-supported storage system that moves storage carriers past an operator station.

B. Bin Storage

Bin storage is designed primarily to accommodate small, rapid moving items, such as repair parts, hand tools, and hardware.

C. Medium Storage

Medium storage locations are those locations designed to accommodate items that are too large by either size or quantity for bin storage, but not large enough to warrant placement into an individual storage location or container.

D. Bulk Storage

A bulk storage location consists of those items that by either size or quantity warrant placement in an individual storage location or container.

030303. Storage Layout

The layout of storage space and facilities should:

- A. Properly identify building, bays and areas.
- B. Provide for efficient receiving, issuing, packing, and shipping processes.

- C. Be sufficiently versatile to meet all storage situations.
- D. Be fully responsive to mechanized materiel handling.
- E. Meet every requirement of computer processing of documentation that affects receipt, storage, and issue of supplies.
- F. Facilitate effective space management.
- G. Provide a pattern which is compatible with efficient work methods for storing and withdrawing stocks.
- H. Provide appropriate distances between items, walls, and doors for safety purposes.

030304. Planograph

A planograph is a drawing of the actual layout of a storage structure or outside storage area. The planograph portrays the manner in which the gross space within the storage structure or outside storage area is subdivided. These subdivisions can be for such functions or uses as storage areas, shipping and receiving areas, main aisles, working aisles, locker or restrooms, and offices. The warehouse manager or chief of the storage activity is responsible for the preparation and use of planographs.

030305. Marking of storage area

The standard markings of the storage complex and containers are essential for the rapid and orderly assembly and location of supplies. Adhere to the following general rules for the marking of the storage complex and container (see Appendices M and N):

A. Enclosed/Improved Storage

Make markings with suitable traffic paint on floors or paving, or enamel on signs or placards.

1. Area. Mark each building and storage lot with a 6-inch letter adjacent to their traffic entrance, indicating its assigned area.
2. Station. At the intersection of stations, post floor markings or signs that indicate the area and station. Within stations of sufficient size to require further markings, indicate the area and station at the intersection of transportation/traffic aisles and rows.
3. Aisle/Row. Paint aisle/row numbers on the floor or signs in such a manner that they are readily visible to a person entering the row from either direction.

4. Segment. Paint the segment number painted in such a manner that it is readily visible when standing in front of the segment. Place the number so that it is centered on the segment to which it applies.

5. Level. Paint the level of bins and racks on the center of the shelf or cross-member and indicate that the supplies placed at that level (i.e., never interpret the level to apply to supplies stored below the level marking).

6. Compartment. Mark compartments from left to right within the level when facing the segment (see Appendix M).

B. Marking Containers

Mark containers as the following (see Appendix N):

1. Bin Unit Markings. Place the location markings on the container as shown in Appendices M and N. The lettering shall be in 1-inch black block letters on the containers and 1/2-inch-high yellow or white block lettering on the inserts.

2. Medium/Bulk Storage Containers. Mark medium and bulk containers as indicated in Appendices M and N. The location markings shall be in 3-inch-high black block lettering.

3. Unimproved Storage. Mark unimproved storage in the same basic manner; however, use staked and un-staked placards rather than floor markings.

030306. Stock locations

A. General

Proper stock locations are essential to effective warehousing. Establish and maintain stock location numbers and files in such a manner to permit rapid location of supplies both in garrison and deployed environments.

B. Physical Location Codes

1. The physical location code is a part of the item locator file. Use the physical location code to physically identify each individual storage location.

2. There are two stock location numbering systems the Marine Corps uses: the non-tactical and the tactical unit locator systems.

3. Non-deploying units and units that normally do not deploy as a complete entity (deploy in blocks; i.e., GSA, IIP, SMU, etc.) use the non-tactical unit locator system.

4. All other units use the tactical locator system.

C. Non-tactical Locator System

The non-tactical stock location system can consist of up to fifteen characters; normally shortened to nine characters to be easily read. The nine characters consist of alpha and numeric combinations, as follows:

1. Area/First Position/Alpha. The first character is alpha and may represent a group of buildings within a complex, an open storage area, a single building or a warehouse, a shed, or a floor when utilizing a multi-story warehouse.
2. Station/Second and Third Positions/Numeric. The second and third characters are numeric. Use these characters to identify a station within an area. These digits may be used to identify stock picking stations, stations receipt of materiel for stowing, packing stations, floors of building, sections of a warehouse, or a building within an area. These digits may also identify collection, assembly, or drop-off stations in a mechanized warehouse system.
3. Aisle or Row/Fourth and Fifth Positions/Numeric. The fourth and fifth characters are numeric. Use these characters to identify aisles or rows within a station. Use an individual numbering system within each station.
4. Segment/Sixth and Seventh Positions/Numeric. The sixth and seventh characters are numeric. Use these characters to identify segments of a rack, or container. A segment may be short lot or stack.
5. Level/Eighth Position/Alpha. The eighth is alphabetic. Use this character to identify the level within a rack, or container. Where not applicable, such as bulk storage, assign the letter "A."
6. Compartment/Ninth Position/Alpha. The ninth character is alphabetic. Use this character to identify a subdivision of the level within a rack or container. Where not applicable, such as bulk storage, assign the letter "A."

D. Tactical Locator System

The deployable unit location system was designed to provide units with as much flexibility as possible. The stock location number consists of nine alpha/numeric digits as outlined herein.

1. Embark, Serial, and Tactical Markings/First Four Positions/Alpha/Numeric. The first four characters may be alpha/numeric depending on the unit's needs. Use these positions primarily for embarkation numbers, serial numbers, and tactical markings; however, these characters may be used for other purposes, as required. Use these positions to identify buildings/dumps or in conjunction with positions five through seven to expand box number availability. The unit must have the CO identify in writing how these positions are being used. It is recommended that control of these positions reside at the major subordinate element level.

2. Type of Storage/Fifth Position/Numeric. The fifth character is numeric. Use this character to identify the type of storage. If equipment is located by type of storage, use this position in conjunction with positions six and seven to expand the range of box numbers from 99 to 297.

3. Box or Container/Sixth and Seventh Positions/Numeric. The sixth and seventh characters are numeric. Use these characters to identify the box or container number.

4. Level/Eighth Position/Alpha. The eighth character is an alpha character and represents the level within the container. Where not applicable, such as in bulk containers, assign the letter "A."

5. Compartment/Ninth Position/Alpha. The ninth character is an alpha character and identifies a subdivision of the level within the containers. Where not applicable, such as in bulk containers, assign the letter "A."

0304 SAFETY

030401. General

Make safety an integral part of storage operations. In all matters dealing with accident prevention, warehouse supervisors are responsible for instituting a suitable program and using the technical services of the Installation Safety Director or Safety Program Manager. Commanders will take steps to ensure the enforcement of the accident prevention program in storage operations. Occupational safety and health requirements set forth in this chapter are based in part on reference (at).

A. Supervisory or safety personnel will analyze each physical operation to determine inherent and manmade hazards. Develop operating procedures that either remove or control identified hazards.

1. Methods of control include: substitution with safer equipment or procedures; isolation of hazardous operations; mechanical guarding; redesign of facility and/or equipment layout; and others.

2. Installation safety specialists can greatly assist units in developing hazard controls to satisfy specific safety requirements.

B. Accidents involving personnel can have an adverse effect on scheduled and unscheduled events. Accidents affect the availability of personnel or required skills, which results in the loss of productive man hours.

C. When material is damaged or destroyed by accident, costs are incurred to accomplish necessary repairs and or replacement of material. Other consequences include production delays and a possible shortage of critical material.

D. Investigate and report all accidents involving military, civilians, and contractors in accordance with the command's existing procedures. Reference (au) provides instructions for reporting accidents.

030402. Safety Program

Commanders will ensure the establishment and management of a safety program for storage and warehouse operations.

030403. Training

Personnel will train to avoid accidents. The warehouse supervisor will establish a storage safety program that includes, but is not limited to the following:

A. Operating personnel must be given proper instruction and training concerning potential dangers associated with their daily tasks.

B. Personnel handling hazardous material must possess knowledge of all potential hazards concerning the commodities under their control.

C. To ensure proper use of equipment, personnel should know the equipment's design, purpose, and limitations.

D. Personnel should train on routine maintenance of equipment to monitor equipment, keep it in proper operating condition, and report unsafe conditions or necessary repairs to the appropriate supervisor.

E. Potential dangers of storage operations as they relate to distance, terrain, elevation of travel, and the amount of aisle space for maneuver.

030404. Personal Protective Equipment (PPE)

When a hazard still exists after all practical control methods have been taken, provide workers further protection through PPE. PPE is based on nature of the hazard. Do not use PPE as a substitute for the elimination or control of unsafe acts and conditions, but rather as a supplemental safety measure.

030405. Fire Protection

A. There are different classes of fire. Each class requires the same class rating for the fire extinguisher. Reference (av) and below lists the basic types of fires and hazards:

1. Class A fires are fires in ordinary combustible materials, such as wood, cloth, paper, and rubber that require a fire extinguisher with Class A rating.

2. Class B fires are fires in flammable liquids, gases, and greases that require a fire extinguisher with Class D rating.

3. Class C fires are fires that involve energized electrical equipment where the electrical non-conductivity of the extinguishing media is of importance. When electrical equipment is de-energized, extinguishers for Class A or B fires may be used safely.

4. Class D fires are fires in combustible metals, such as magnesium, titanium, zirconium, sodium, and potassium that require a fire extinguisher with Class D rating.

B. A sprinkler system, for fire protection purposes, is an integrated system of underground and overhead piping designed in accordance with fire protection engineering standards.

C. A sprinkler alarm unit is an assembly of apparatus approved for the service and so constructed and installed that any flow of water from a sprinkler system equal to or greater than that from a single automatic sprinkler will result in an audible alarm signal on the premises. The system is usually activated by heat from a fire and discharges content over the fire area.

D. Mark all fire exits and fire extinguishers and include in the warehouse layout in accordance with reference (av).

030406. Orderliness

Good housekeeping practices are as essential to safety and efficient storage operations. Many potential accidents and fires are prevented when units maintain warehouses, storerooms, and outside storage areas in a clean and orderly condition. All areas of storage space should, at a minimum, enforce the following housekeeping rules:

- A. Provide adequate lighting.
- B. Keep machines, equipment, and working surfaces clean and orderly.
- C. Clean up work areas as soon as work is completed. Remove hazardous objects from floor or ground areas during work.
- D. Allow eating only in authorized places.
- E. Clean up immediately any spilled dangerous or slippery substances from working floors or paved areas.
- F. Use containers, pallets, and units of sound construction only.
- G. Maintain proper and safe storage of hazardous packing materials such as excelsior, sawdust, wood cellulose, preservative liquids, and chemicals.
- H. Provide ample space in aisles and work areas to avoid congestion.
- I. Eliminate tripping hazards such as electrical, telephone, and light cables.

J. Place flammable waste (such as oily rags, steel wool, and sweepings of excelsior) in special covered metal containers and dispose of regularly. Place ashes in noncombustible containers.

K. Store dunnage material in an orderly manner.

L. Provide regular inspections by supervisory personnel to detect unsafe conditions or acts, and check for cleanliness.

M. Maintain adequate emergency firefighting equipment and access thereto.

N. Prohibit smoking and/or the consumption of alcohol in or near warehouse facilities and storage locations.

030407. Materiel Storage

Place all materiel, whether palletized or un-palletized, in a safe manner. Ensure that storage containers are square and level to floor or ground. Limit the height of racks or stacks by equipment to maintain clearances and floor load capacity. The general clearance between stored materials and wall is 24 inches. More details can be found in reference (w). Below are general rules:

A. There will be 18 inches clearance of fire sprinklers when rack or stack height does not exceed 15 feet and 36 inches when rack or stack exceeds fifteen feet.

B. There will be a 36 inch clearance in non-sprinkler buildings regardless of the rack or stack height.

C. When subsistence items susceptible to infestation are stored in general purpose buildings, a clearance of 18 inches will be maintained.

D. With the exception of 24 inches of clearance around personnel doors and fire aisles, no clearance is required when nonhazardous materials are stored in general purpose storage buildings.

E. Provide clearance signs to warn of clearance limits.

030408. Material Handling Equipment (MHE)

Follow safety practices for powered MHE and train operators on the proper use of equipment. More guidance is provided in reference (aw). Adhere to the following regulations:

A. Train operators under the prescribed training program for the operation of equipment. Operators will pass all physical and aptitude examinations required.

B. Operators will use the proper type of equipment for the specific job involved.

13 JUN 2016

- C. Equipment will be of the correct rated load capacity for the weight of material to be handled.
- D. Properly service and maintain equipment at all times to assure maximum safety and efficiency in its operation.
- E. Operators will fill out an operator's daily checklist.
- F. Operators will consistently use non-powered MHE according to its intended purpose and provided instructions. Supervisory personnel will provide training on use.
- G. Instruct personnel who manually handle materials of any type on the proper method of lifting heavy objects. Reference (ax) provides guidance.

030409. Hazardous Material

Personnel receiving, handling or storing hazardous material will receive appropriate training. References (ay), (az), (ba), and (bb) provide additional procedures and guidance. The Marine Corps approved Hazardous Material Tracking System will be used by unit HAZMAT representatives for shelf-life management and recording of receipts, issues, transfers and disposals of hazardous materials.

0305 FIELD WAREHOUSING

030501. General

The rapid processing of supplies and equipment from rear areas into advanced supply points is essential to supply support. Through advanced planning, units can greatly minimize the problems encountered with the establishment of a field supply point. This paragraph provides recommended procedures that are fundamental to field storage operations.

030502. Sites

Consider the following when selecting a storage sites:

A. Primary

Centrally locate the primary field storage location in relation to the supported units and resupply points. The central location of the primary position should allow for maximum support to the using unit.

B. Alternative

Always select an alternative location for use in the event that the primary location cannot be occupied. Alternative locations may be used for the storage of overflow from the primary location.

030503. Field Storage Area

The selection of a field storage area is of major importance in the establishment of a field supply point. In this respect, the following factors should be given careful consideration:

A. Terrain

Good, all-weather characteristics should be present so as not to interrupt storage operations during inclement weather. Potential storage areas should be adequately drained, sufficiently level to sustain operations, and accessible under all weather conditions. An ideal location is one that contains a thin layer of topsoil with hard substrata of coral, sandstone rock, or gravel. Such a location will effectively support the weight of supplies and the wear of heavy traffic. Organic clay and silt soil locations are least desirable and should, if possible, be avoided.

B. Cover

Every advantage should be taken to use all available natural cover. Use discretion in selecting isolated wooded areas as potential storage areas as they provide excellent targets for enemy aircraft and/or artillery.

C. Access Roads

Access roads to potential storage sites should be capable of withstanding heavy traffic, regardless of weather conditions. Alternate access roads are desirable and extremely important in that traffic on a main supply route may become congested or otherwise disrupted, thereby necessitating the use of another road for accessibility to supplies.

D. Fire Protection

Place fire protection devices, such as fire barrels, buckets, fire extinguishers, and hand tools in a readily accessible area to reduce fire losses to a minimum. Ensure all storage and issue point areas are planned with accessibility, escape, egress, and firebreaks to facilitate speedy emergency response, fire suppression, and personnel evacuation.

E. Size/Security

The size of a potential storage area should be large enough to fulfill the necessary storage requirements but not so large as to render it incapable of being defended from light enemy attacks or infiltration.

030504. Supply Point Layout

A field supply point layout is an overlay of the storage area that outlines the location of all supplies and facilities, traffic control points, direction of traffic, and relationship of the forward edge of the battle area.

030505. Types of Re-supply Points

There are basically two types of field re-supply layouts: roadside and depth-storage. Base the use of such layouts upon factors, such as the mission, terrain, road accessibility, and climate. Because of the variable factors that might apply, it is not the intent to prescribe a specific layout that is appropriate to all situations. Rather, the intent is to use basic layouts that units may use or modify, as appropriate, to fit any given situation.

A. Roadside

Figure 3-1 outlines a typical roadside re-supply point. This outline is intended to be used only as a guide in establishing a roadside issue point. It contains the essential storage locations and elements that units must consider in establishing an issue point.

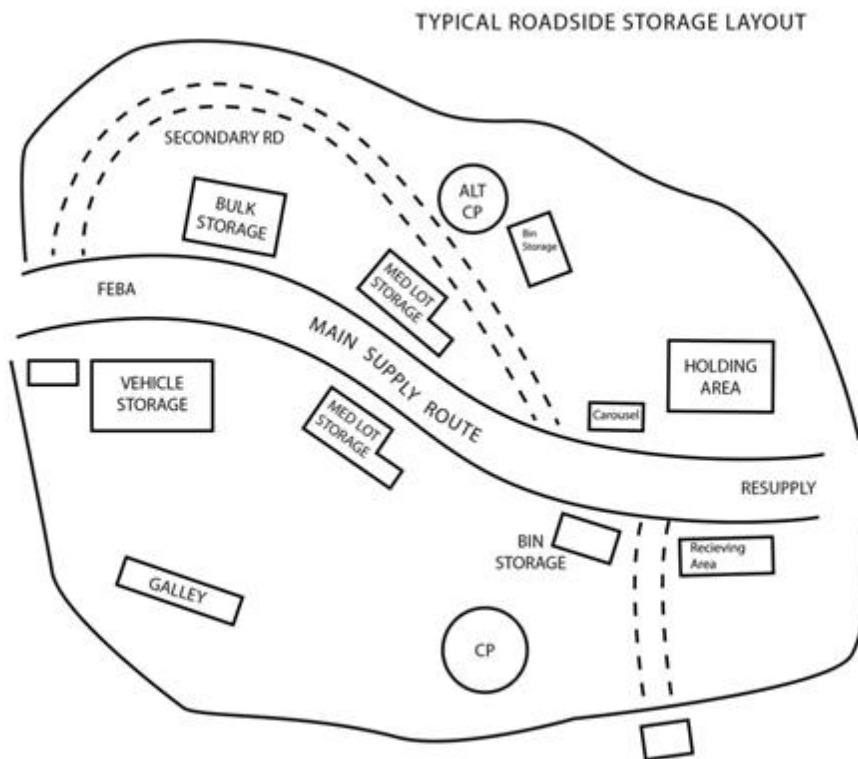

Figure 3-1. Typical Roadside Storage Layout

B. Depth-Storage

Figure 3-2 outlines a typical depth-type storage layout. The depth-storage re-supply point is considered standard for use by supply support units of a MEF. In establishing a depth-storage issue point, primary considerations should be given to the availability to secondary access roads.

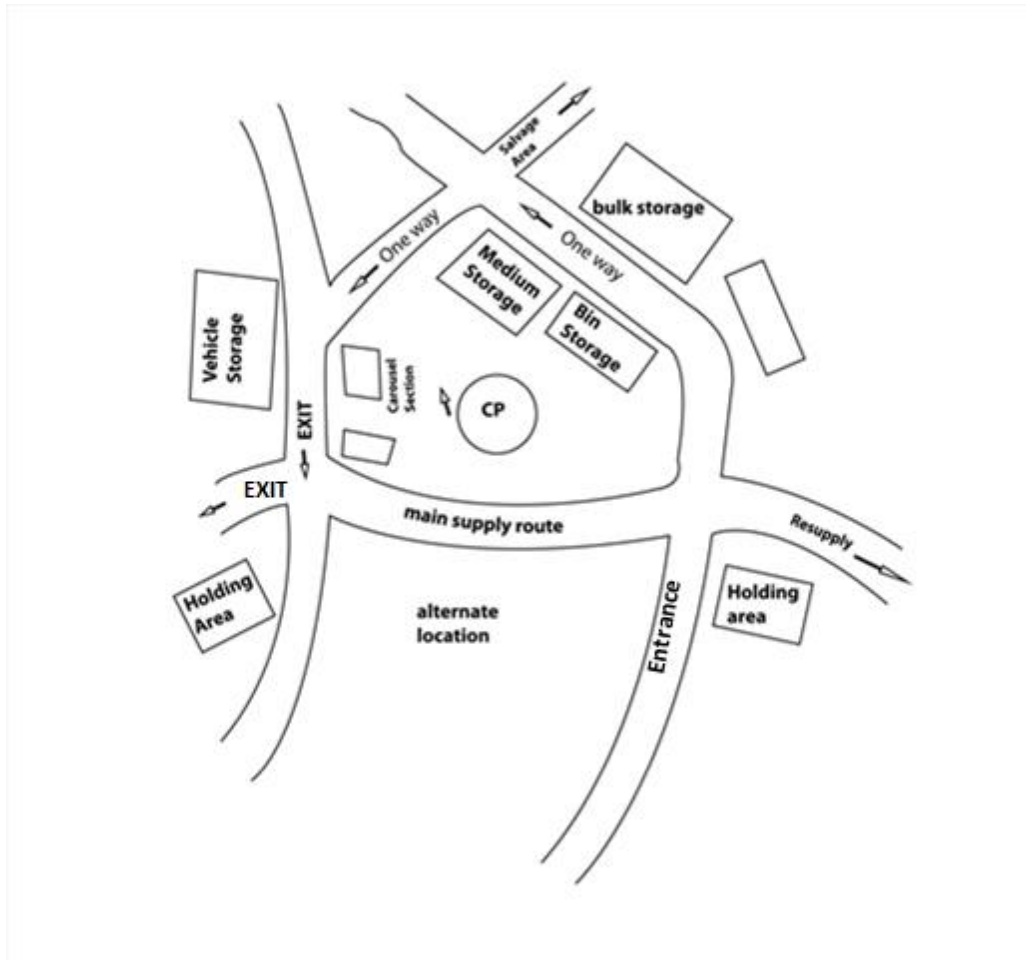

Figure 3-2. Typical Depth-Storage Dump

030506. Protection of Supplies

Warehouse managers are responsible for providing adequate protection from the elements and environmental conditions by providing proper storage facilities, preservation, packing, marking, or a combination of all or any of those measures per reference (am). The three fundamental principles that must be observed in protecting supplies from the elements are adequate storage shelter, dunnage, and ventilation.

A. Adequate Shelter

Adequate storage shelters may be realized through a number of means including, but not limited to, existing buildings, tents, tarpaulins, and/or caves. Some of the considerations in selecting adequate shelter are as follows:

1. Existing Buildings. Existing buildings provide an excellent means of shelter; however, prior to use, inspect buildings for structural adequacy and clear flammable or otherwise dangerous materials and debris. Request engineer support in evaluating the structural integrity and overall safety of buildings.

2. Caves. Caves also afford excellent protection for supplies; however, care must be taken to ensure that caves are reasonably dry and free from moisture seepage and have adequate ventilation.

B. Dunnage

Raise storage stacks off the ground by using suitable dunnage material to ensure adequate ventilation. The type of texture of the soil on which the supplies will be placed and the climatic conditions should dictate the amount and type of dunnage used.

C. Ventilation

Stack material in such a manner to allow two feet of airspace between the top of the stack and the cover. This will enable free circulation of air around, under, and between storage containers.

D. Stock locator system

Stock location systems must pinpoint exact storage locations in a simple, easily understood manner. Clearly display suitable location markings. Establish procedures to ensure positive control of all additions, deletions, and changes to the stock locator file. At least annually (or more often if warranted), validate stock locator systems to ensure accuracy. Give special care to shelf-life and hazardous material. Units will identify shelf-life items on storage locator records by Shelf-Life Codes (Appendix O) and Supply Condition Codes (Appendix P).

1. For Type I items, store shelf-life items in separate bin, rack, and floor locations by NIIN, date manufactured, date cured, date assembled, date packed (subsistence only), and expiration date. For Type II items, store shelf-life items by the NIIN, date manufactured, date cured, date assembled, date packed, and date inspected or date tested. Store shelf-life items with one lot or batch per storage location.

2. Store and segregate hazardous materials by their respective hazardous material characteristics code and individual manufacturer.

VOLUME 3: CHAPTER 4

“MISCELLANEOUS ACCOUNTING”

SUMMARY OF SUBSTANTIVE CHANGES

All changes are denoted by **blue font** unless a full revision has been conducted.

Substantive revisions are denoted by a * symbol preceding the section, paragraph, table, or figure that includes the revision.

Hyperlinks are denoted by ***bold, italic, blue and underlined font***.

Base date of this Marine Corps Order (MCO) Volume (right header) will not change unless a full revision has been conducted. Upon full revision of this Volume, all changes denoted by blue font will reset to black font.

PAGE PARAGRAPH	EXPLANATION OF SUBSTANTIVE CHANGES	PURPOSE	DATE OF CHANGE

CHAPTER 4

MISCELLANEOUS ACCOUNTING

0401 GENERAL

This chapter pertains to retail-level accounting procedures for property not specifically addressed elsewhere in this Volume.

0402 RETENTION OF RECORDS AND SECURE STORAGE FOR CASH COLLECTION

040201. In accordance with Chapter 2 in this Volume, retail activities will maintain a record of each cash collection transaction involving reimbursement for missing, lost, destroyed, or damaged government property.

040202. Units will maintain on file appointment and revocation letters, signed by the CO, for the authorized custodian, alternate custodian(s), and audit and verification officer.

040203. Units will maintain records of the collection of funds, quarterly audit and verification, and deposit of funds with the disbursing officer.

040204. Unless protected by controlled access (to include alarm systems, security guard/patrols, or monitoring systems), units shall bolt to the deck, safes weighing up to 1,500 pounds that are mounted with wheels or casters.

040205. Volume 5 (Disbursing Policy) of reference (e) provides specific procedures.

0403 SENSITIVE OR CONTROLLED BLANK FORMS ACCOUNTABILITY

040301. Retail supply activities will provide accounting and physical security measures to prevent theft or misuse of sensitive or controlled blank forms. Reference (bc) identifies these forms. When sensitive blank forms have serial numbers, serialized control is required. Sensitive blank forms will only be issued to authorized recipients. The CO will designate in writing individuals authorized to receive or maintain sensitive or controlled blank forms. Each authorized recipient will provide a sample signature that will be kept on file by the supply officer/APO. On a monthly basis, units will maintain and inventory all receipts, issues, and on hand quantities for sensitive or controlled blank forms that supply maintains. Reference (bd) provides policy and additional information.

040302. Supply accountability and inventory requirements pertain only to sensitive blank forms within the supply distribution system until issued to the user. After procurement, units will maintain a record of issues including serial numbers.

0404 PERSONAL EFFECTS AND BAGGAGE

The CO is responsible for the handling of uniform clothing, personal effects, and government property for certain individuals (e.g., deceased, hospitalized, or in an unauthorized absence). In accordance with Volume 13 of this Order, the CO will control, safeguard, and process personal effects and baggage.

0405 PACKAGED OPERATIONAL RATIONS

040501. Packaged Operational Rations (PORs) will be requisitioned in accordance with references (be) and (bf). Unless directed by higher headquarters, consumer-level supply activities will not stock PORs. Only intermediate-level activities are authorized to store subsistence items.

040502. References (be) and (bf) provide policy for conducting sales of PORs.

0406 ACCOUNTING FOR CLASSIFIED MATERIEL

Units will receipt for, store, and issue all materiel coded as “classified” in the management data list per instructions contained in reference (bg).

0407 ACCOUNTING FOR MEDICAL AND DENTAL SUPPLIES AND EQUIPMENT

Retail-level accounts will not use O&M, MC or Operations and Maintenance, Marine Corps Reserve (O&M, MCR) funds for garrison medical or dental care. The management and procurement of Authorized Medical Allowance List (AMAL) and Authorized Dental Allowance List (ADAL) materiel will be issued, recorded, and controlled in the same manner as Marine Corps property. Formal requirements for Class VIII medical equipment in support of a unit's mission are included in a unit's T/E. The OPFORs hold and manage a 15-day requirement of AMALs and ADALs that serves as war reserve or continuance stocks. Medical Logistics Companies account for, maintain physical custody of, sustain, and modernize AMALs and ADALs for their supported units while those units are at home station. References (bh) and (bi) provide further guidance.

0408 TEMPORARY LOANS OF ORGANIC EQUIPMENT

040801. Internal Temporary Loans

Internal temporary loans include the loaning of organic equipment from an owning Marine Corps unit to another Marine Corps unit within the same Marine Force. Temp loans will be tracked using NAVMC 10359, “Equipment Custody Record.”

A. It is inadvisable to conduct temporary loans between units belonging to different commands; however, upon determination by next higher level chain of command (i.e., the lowest level in which the supporting and supported unit have in common) that such a loan is necessary and in the best interest of the unit, a loan may be authorized. As a general rule, temporary loans of organic property will be made for 30 calendar days. If necessary, the loan may be renewed every 30 calendar days; however, temporary loans will not exceed one year in duration. If the

requirement for the equipment exceeds one year, then the borrowing unit must identify the requirement through the submission of a TOECR.

B. Temporary loans are not a substitute for authorized allowances. When possible, units will anticipate equipment requirements and initiate changes to T/E allowances.

C. The CO of the lending unit will establish procedures to ensure recovery of property issued on temporary loan. The lending unit will annotate the duration and expiration date of the loan on the loan document. Lending units will maintain temporary loan records separately from permanent issue records of organic equipment and supplies. A NAVMC 10359 is the standard document for temporary loans; however, lending units may use locally generated documents. If a NAVMC 10359 is used, the lending unit will ensure all required fields are completed. If a locally generated document is used in lieu of a NAVMC 10359 the lending unit will ensure the locally generated document contains the same required information as the NAVMC 10359. Unit property records will not be adjusted as a result of temporary loans. When possible, a Joint Limited Technical Inspection (JLTI) will be done to determine the serviceability of the requested items for temporary loan. The JLTI will also include an inventory of SL-3 components to determine if any deficiencies exist upon issue.

D. The borrowing unit will cover all costs to return temporarily loaned equipment to a serviceable condition to include all costs of replacing SL-3 deficiencies resulting from the temporary loan. When possible, a JLTI will be done to determine associated costs. The responsibility for investigating and adjudicating missing, lost, damaged or destroyed temporarily loaned equipment resides with the borrowing unit. The borrowing unit will route the completed investigation to the loaning unit via the Staff Judge Advocate.

E. Units are not authorized for temporary loans of equipment from MARCORLOGCOM inventory stores to fill temporary requirements. Units may request the establishment of a special allowance and the resulting authority to receive equipment from MARCORLOGCOM inventory stores to fill emerging short-term operational requirements. Refer to paragraph 020509 of Chapter 2 in this Volume for information regarding the establishment of special allowances.

F. For temporary loans between units belonging to separate MARFORs, the requesting unit will route a request to DC I&L (LP) for approval. For temporary loans between units belonging to separate supporting establishments, the requesting unit will route a request to DC I&L (LF) for approval. Authorization is granted for the establishment of Memorandums of Understanding between MARFORRES and the other MARFORs to support the temporary loan of equipment for MARFORRES annual training events without DC I&L (LP) approval.

G. Units at the retail level of supply are not authorized to temporarily loan equipment or supplies to DoD agencies or contractors. Refer to paragraph 040802.B below for additional information.

H. Per reference (y), the temporary loan of small arms/light weapons is highly discouraged and will not exceed 30 days. Refer to reference (y) for policy pertaining to the temporary loans of small arms/light weapons.

040802. External Temporary Loans

External temporary loans include the loaning of equipment to an external organization (i.e., an organization outside of the Marine Corps) such as a DoD agency, government agency, veteran organization, coalition force, or non-governmental organization. External temporary loans to contractors are not authorized as any property in the possession of, or directly acquired by, the government and subsequently furnished to a contractor for performance of a contract is GFP. GFP also includes CAP if the CAP is a deliverable under a cost contract when accepted by the government for continued use under the contract. Refer to Volume 10 of this Order for policy and additional information pertaining to external temporary loans, GFP, and CAP.

040803. Receipt of Temporary Loans from External Agencies

Requirements may dictate the need to receive a temporary loan from an external agency to meet certain mission requirements (e.g., MARCORSSYSCOM R&D, support contingency operations, training exercises, etc.). Such loans will be executed in accordance with the supporting unit policies and will be coordinated with and executed by the gaining unit supply officer. The supply officer will act as the RO to the supporting unit and will coordinate the internal issue to a responsible individual/commodity. With the exception of SIE assets, units will not add temporary loaned equipment from external agencies to the official property records.

0409 HERITAGE ASSETS AND DISPLAY EQUIPMENT

140901. Definitions

A. Heritage Assets

In accordance with Volume 4 (Accounting Policy) of reference (e) and reference (af), heritage assets are of historical or natural significance; cultural, educational, or artistic importance; or possess significant architectural characteristics. As a result, DON heritage assets are to be preserved in museums or registered with the Naval Historical Center or the National Museum of the Marine Corps (NMMC). Although heritage assets have physical properties that resemble those of general property, plant and equipment, heritage asset values may be indeterminable or may have little financial significance (e.g., museum collections, monuments, assets acquired in the formation of the nation). Thus, allocating the cost of heritage assets to certain accounting periods may not be meaningful per Volume 4 (Accounting Policy) of reference (e). As a result, units in possession of heritage assets will maintain stewardship responsibility with no financial reporting requirements.

B. Display Equipment

Per Volume 4 (Accounting Policy) of reference (e), display equipment is defined as old or obsolete military equipment that is not considered to warrant museum-level heritage significance, but is on display at military installations. Display equipment is not considered a heritage asset and will be accounted for as garrison personal property.

040902. National Museum of the Marine Corps

In accordance with reference (bj), the responsibility for recording, preserving, and disseminating the cumulative operational and institutional experience of the Marine Corps rests with the NMMC, History Division, and the Archives and Special Collections Branch of the Library of the Marine Corps. Along with other missions outlined in reference (bj) the NMMC will: preserve and exhibit the material history of the U.S. Marine Corps; honor the commitment, accomplishments, and sacrifices of Marines; and provide the public with a readily accessible platform for the exploration of Marine Corps history. As part of this mission, the NMMC provides collection and collection management services. The NMMC also loans artifacts to organizations that demonstrate the ability to provide temporary stewardship responsibility. Accordingly, the NMMC is the sole organization responsible for the management of USMC heritage assets and commands will execute stewardship responsibility.

040903. Reporting Categories

Material that may be identified as heritage asset or display equipment may fall into one of three reporting categories: Class II/VII military equipment; other than class VII military equipment; or foreign SA/LW.

A. Class II/VII Military Equipment

As defined in Volume 1 of this Order, prior to designation as heritage assets or display equipment, major end items require centralized individual management and MARCORLOGCOM and MARCORSYSCOM review. Only Class VII military equipment that is excess to enterprise requirements or unserviceable beyond repair will be considered for retention as heritage assets or display equipment.

B. Other-than-Class-VII-Military Equipment

Other-than-Class-VII-Military Equipment includes non-Class VII items that are neither centrally managed nor require MARCORLOGCOM and MARCORSYSCOM review prior to designation as heritage assets or display equipment. Other-than-Class-VII-Military Equipment also includes non-DoD funded property (i.e., acquired through some other means such as contingency operations or private donations). Non-DoD funded property typically includes, but is not limited to: individual clothing and combat equipment (e.g., uniforms, canteens, etc.); unit identification items (e.g., flags, guidons, etc.); and non-SA/LW foreign military assets (e.g., vehicles, communication equipment, etc.). Due to its nature, foreign SA/LW systems are not included in this category (see paragraph 140903.C below).

C. Small Arms/Light Weapons

1. Only SA/LWs, as classified in reference (y), that are of historical significance, excess to enterprise requirements, or unserviceable beyond repair may be considered for retention as heritage assets or display equipment.

13 JUN 2016

2. "Heritage" weapons will be accounted for in the Department of the Navy Heritage Asset Management System (DONHAMS) and reported to NSWC Crane by the NMMC personnel. There is no MSI requirement for Heritage Asset SA/LW while on display. Units will physically site the displayed Heritage Asset SA/LW's on a daily basis. Discrepancies should be reported to NMMC or PMO accordingly. Units will sign an annual loan agreement with NMMC, at which time the SA/LW's must be verified by serial number, and a photograph and condition report must be submitted. Heritage Asset SA/LW on loan to a unit may be used for display purposes only, and must be secured while on display in accordance with reference (x).

3. "Display" weapons will be accounted for in DPAS. The supported unit (i.e., a command in possession of "display" SA/LW which has AO authorities) is responsible for reporting "Display" SA/LW to the supporting unit (i.e., installation/base commander, which is assigned garrison property AO responsibilities) for inclusion and adjustment to DPAS.

4. NSWC Crane reporting of "Display" SA/LW will be established/coordinated and maintained by the supporting command with NSWC Crane sub-accounts established for supported units.

5. MSIs, physical security screenings, investigations, MLSRs, etc. are the responsibility of the supported unit. MSIs along with all key supporting documents shall be retained by the supported unit in accordance with paragraph 021002 of this directive and will only be forwarded to the supporting unit whenever there is a required inventory change/adjustment to APSR/NSWC Crane.

040904. Maintenance Funding

Commanders are responsible for funding the maintenance of authorized heritage assets and display equipment on conditional loan to unit-level commands. Accordingly, to ensure that resources are available to maintain assets in an acceptable and safe condition, commands with physical possession of the assets must identify in advance maintenance funding requirements to the supporting installation commander. When requesting heritage assets or display equipment on a conditional loan, this requirement must be considered.

040905. Approval Authority

A. Heritage Assets

The NMMC is the final approval authority for accepting material as a heritage asset.

B. Conditional Loans of Heritage Assets

The acceptance of an asset into the NMMC collection as a heritage asset is not authorization for a command to physically retain the asset. MCICOM is the final approval authority for accepting a heritage asset on a conditional loan from the NMMC.

C. Display Equipment

MCICOM is the final approval authority for accepting material as display equipment. Requests will only be considered if the NMMC has denied adding the requested asset to their heritage asset collection.

040906. Procedural Overview

To ensure that all enterprise equities are met, all requests for classifying and retaining material as heritage assets or display equipment will follow the below two-step procedure.

A. Step 1 – Heritage Asset Determination

Regardless of the reporting category, units in the possession of a potential heritage asset will forward the asset information to the NMMC. The NMMC will determine whether or not the asset will be accepted into their collection as a heritage asset. Refer to paragraph 040907 for additional guidance.

B. Step 2 – Request for Physical Retention

Units that desire to maintain physical possession of an approved heritage asset must request approval via the unit's chain of command and appropriate Marine Corps organizations (i.e., MARCORLOGCOM, MARCORSYSCOM, and MCICOM). Units will submit the request for conditional loan retention, or a request for display equipment retention (for assets denied acceptance as a heritage asset). Refer to paragraphs 040908 and 040909 below for additional guidance.

040907. Heritage Asset Determination

Using the format provided in Appendix K, units must submit a request for heritage asset determination to the NMMC. This request is not an authorization for the unit to physically retain the asset. Instead, the request serves to report the item to the NMMC as a potential heritage asset due to the item's possible historical significance.

A. Forwarding Address

Forward requests to: National Museum of the Marine Corps, (Attention: Registrar), 18900 Jefferson Davis Highway, Triangle, VA 22134, DSN 278-2608.

B. Review of Request

The NMMC will review the request to determine the reporting category of the item and whether to accept the asset into the NMMC's collection as a heritage asset. When required, the NMMC will consult with DC I&L (LP) to determine the appropriate reporting category. The NMMC will respond to the request by: approving or denying the asset's acceptance as a heritage asset; identifying the appropriate reporting category; and providing the requesting unit with appropriate follow-on action.

1. Prior to responding to any request for assets in the reporting categories identified in paragraphs 040903.A and 040903.C, the NMMC will coordinate with MARCORSYSCOM and MARCORLOGCOM. If the item is accepted into the NMMC collection as a heritage asset, then the NMMC will add the asset to the NMMC's property records and direct the requesting unit to conduct the actions in paragraph 040908 below. If denied acceptance as a heritage asset, NMMC will direct the requesting unit to conduct the actions in paragraph 040909.

2. For any request to retain Other-than-Class VII-Military Equipment, the NMMC will directly respond to the requesting agency. If accepted into the NMMC collection as a heritage asset, the NMMC will add these assets to the NMMC's property records and the NMMC will direct the requesting unit to conduct the actions in paragraph 040908. If denied acceptance as heritage assets, the NMMC will direct requesting units to conduct the actions in paragraph 040909.

040908. Requesting Conditional Loan Retention of Heritage Assets

Within 90 days of notification that an item has been accepted into the NMMC collection as a heritage asset, the requesting unit will perform the following actions.

A. Delivery to NMMC

If the unit does not desire to maintain physical possession of the heritage asset, then the unit will deliver the heritage asset to the NMMC.

B. Maintain Physical Possession

If the unit desires to maintain physical possession of the heritage asset, then the unit will submit a request for conditional loan using the letter format provided in Appendix L. The unit's chain of command and supporting (i.e., home station) installation commander will endorse all requests. In operational environments, the component and combatant commander will endorse the request. Based on the asset reporting category, units will route endorsed requests to the appropriate Marine Corps organizations (i.e., MARCORLOGCOM, MARCORSYSCOM, or MCICOM). The following procedures apply:

1. For conditional loan retention of assets in the reporting categories in paragraphs 040903.A and 040903.C, units will submit requests to MARCORLOGCOM via the GCSS-MC Service Request process.

a. MARCORLOGCOM will: validate the request against current inventory levels and requirements; provide a favorable or unfavorable endorsement; and forward the request to MARCORSYSCOM.

b. MARCORSYSCOM will: validate the request against life cycle requirements; provide a favorable or unfavorable endorsement; and forward the request to MCICOM.

c. MCICOM will review the request and endorsements and approve or deny the request. If denied for retention on conditional loan, MCICOM will direct requesting unit to deliver the asset to the NMMC. If approved for retention on a conditional loan, MCICOM will

13 JUN 2016

direct the requesting unit to maintain physical possession of the asset and establish stewardship responsibility using the garrison personal property procedures in Chapter 2 of this Volume. When applicable, the NMMC will coordinate the final determination to develop the conditional loan agreement for inclusion in the final disposition instructions.

d. MARCORLOGCOM will provide final disposition instructions to the requesting unit via the original GCSS-MC Service Request. The GCSS-MC Service Request response will include: the approval or denial endorsements; appropriate disposition instructions; and any additional required instructions (e.g., demilitarization instructions, asset identification number, transfer procedures, MCICOM maintenance requirements, etc.).

2. Units will submit requests for conditional loan retention of assets in the reporting category in paragraph 040903.B to MCICOM.

a. MCICOM will review the request and applicable endorsements and make a final determination to approve or deny the request. If denied for retention on conditional loan, MCICOM will direct the requesting unit to deliver the asset to the NMMC. If approved for retention on conditional loan, MCICOM will direct the requesting unit to maintain physical possession of the asset and establish stewardship responsibility per the garrison personal property policy in Chapter 2 of this Volume. When applicable, the NMMC will coordinate the final determination to develop the conditional loan agreement for inclusion in the final disposition instructions.

b. MCICOM will coordinate with NMMC and provide final disposition instructions to the requesting unit. Disposition instructions will include: the approval or denial endorsement; appropriate disposition instructions; and any additional required instructions (e.g., demilitarization instructions, asset identification number, transfer procedures, MCICOM maintenance requirements, etc.).

040909. Requesting Display Equipment Retention

When an item has been denied acceptance into the NMMC collection as a heritage asset, the requesting unit will conduct the following actions.

A. Disposal Actions

If a unit does not desire to maintain physical possession of an asset, the unit will dispose of the asset in accordance with references (d) and (i). For the disposal of display equipment in the reporting categories identified in paragraphs 040903.A and 040903.C, units will submit requests to MARCORLOGCOM requesting disposition instructions via the GCSS-MC Service Request process.

B. Maintain Physical Possession

If a unit desires to maintain physical possession of an asset, the unit will submit a request to retain the asset as display equipment using the letter format in Appendix L. The unit's chain of command and supporting (i.e., home station) installation commander will endorse all

requests. In operational environments, the component and combatant commander will endorse the request. Based on the asset reporting category, units will route endorsed requests to appropriate Marine Corps organizations (i.e., MARCORSYSCOM, MARCORLOGCOM, or MCICOM). The following procedures apply:

1. For the retention of display equipment in the reporting categories identified in paragraphs 040903.A and 040903.C, units will submit requests to MARCORLOGCOM via the GCSS-MC Service Request process. In submitting the request, the unit must ensure the justification speaks to the historical significance of the requested item as it pertains to the requesting unit.

a. MARCORLOGCOM will: validate the request against current inventory levels; provide a favorable or unfavorable endorsement; and forward the request to MARCORSYSCOM.

b. MARCORSYSCOM will: validate the request against life cycle requirements; provide a favorable or unfavorable endorsement; and forward the request to MCICOM.

c. MCICOM will review the request and endorsements and approve or deny the request. In reviewing the request, MCICOM will consider the historical significance of the requested item as it pertains to the requesting unit. If denied for retention as display equipment, MCICOM will provide the requesting unit with appropriate disposition instructions in accordance with references (d) and (i). If approved for retention as display equipment, MCICOM will direct the requesting unit to maintain physical possession of the asset and to establish accountability per the garrison personal property policy in Chapter 2 of this Volume.

d. MARCORLOGCOM will provide final disposition instructions to the requesting unit via response to the original GCSS-MC Service Request. The GCSS-MC Service Request response will include: the approval or denial endorsements; appropriate disposition instructions; and any additional required instructions (e.g., demilitarization instructions, asset identification number, transfer procedures, MCICOM maintenance requirements, etc.).

2. The unit will submit requests to retain display equipment in the reporting category in paragraph 040903.B to MCICOM.

a. MCICOM will review the request and applicable endorsements and make a final determination to approve or deny the request. If denied for retention as display equipment, MCICOM will direct the requesting unit to dispose of the asset in accordance with references (d) and (i). If approved for retention as display equipment, MCICOM will direct the requesting unit to maintain physical possession of the asset and establish accountability using the garrison personal property procedures discussed in Chapter 2 of this Volume.

b. MCICOM will provide final disposition instructions to the requesting unit. Disposition instructions will include: the approval or denial endorsement; appropriate disposition instructions; and any additional required instructions (e.g., demilitarization instructions, asset identification number, transfer procedures, MCICOM maintenance requirements, etc.).

040910. Amplifying Accountability Instructions

A. Approval Granted

If approval is granted to maintain an asset on a conditional loan, the unit will transfer ownership and SA/LW reporting responsibilities to the NMMC.

1. The CO/AO will sign and attest to the conditional loan agreement and return the conditional loan agreement to the NMMC.
2. The requesting unit will retain a copy of the conditional loan agreement and disposition instructions and establish stewardship responsibility for the asset within the APSR for general equipment (i.e., garrison personal property). Heritage assets are accounted for by the NMMC, loaned to the unit, and the unit's stewardship is reflected in DONHAMS.
3. On an annual basis and in accordance with reference (af), the NMMC will inventory and reconcile property records heritage assets.
4. If the unit no longer desires approved heritage assets, the unit will submit a request for disposition instructions via the chain of command to the NMMC.

B. Retention as Display Equipment

When MCICOM authorizes an asset for retention as display equipment, the installation commander will establish and maintain ownership to include SA/LW reporting responsibilities. If the unit no longer desires approved display equipment, the unit will submit a request for disposition instructions via the chain of command to MCICOM.

C. Small Arms/Light Weapons

The unit with stewardship responsibility will ensure physical security of SA/LW that are authorized as heritage assets or display equipment (as classified by reference (y)). NMMC will conduct serialized reporting to NSWC Crane.

1. For the purposes of serialized control of small arms/light weapons reporting, units in custody of small arms/light weapons classified as heritage assets (NMMC) or display equipment (MCICOM) will report any movement of such assets to the owning organization.
2. Regardless of the origin, this is an additional accounting function required for all small arms/light weapons the organization retains (e.g., an AK-47 Rifle attached to a plaque mounted in the CO's office or in a hallway).
3. Units will not perform limited demilitarization prior to receiving disposition instructions. Upon performing limited demilitarization, the unit must keep a copy of the demilitarization certificate on hand for all small arms/light weapons. In addition, the unit must bolt and firmly secure to the bulkhead, or display in a securely locked case, all displays (i.e., heritage assets and display equipment). Until these requirements are met, the unit must store in an armory

any SA/LW that lacks a proper limited demilitarization certificate or is not securely bolted or displayed.

4. If the unit no longer desires small arms/light weapons as display equipment, the unit will take actions directed in paragraph 040909.A.

D. Supporting Documentation

The possessing unit must retain all correspondence and supporting documentation in accordance with paragraph 0210 of Chapter 2 in this Volume. If transferred, all documentation must accompany the item(s).

E. Demilitarization Instructions

If the conditional loan includes assets that require limited demilitarization for display, the approving activity will provide the applicable demilitarization instructions. In the case of museum property, the unit may not perform any limited demilitarization without NMMC authorization and instructions.

0410 FLAGS OR CLOTHING ISSUED FOR BURIAL OF NAVY AND MARINE CORPS PERSONNEL

041001. Reference (bk) provides guidance pertaining to deceased and burial ceremonies.

041002. Burial escorts are not entitled to receive dress blues as the mandatory possession date has elapsed.

041003. When uniform items are not immediately available or organizations are not near a Retail Clothing Outlet, Clothing Sales Store, or Marine Corps Exchange, uniform items can be purchased through the Marine Corps Exchange mail order services at 1-800-368-4088. Retired Marines and their spouses are authorized to use these facilities for the purchase of uniforms for burial.

041004. Reference (bl) contains specific policy and procedures for requisitioning burial flags and clothing for Navy personnel.

041005. Per reference (bk), units will provide burial flags to the Casualty Assistance Calls Officer.

0411 REPAIR, REPLACEMENT, AND DISPOSITION OF FLAGS AND STANDARDS

041101. Volume 13 of this Order provides instructions for the repair, replacement and disposition of Flags and Standards.

041102. Battle standards and guidons that belong to deactivating units or have become unserviceable will be reported to the NMMC as a potential heritage asset utilizing the procedures identified in paragraph 1409 of this chapter. Unless historically significant, units are not required to report national standards that are worn and unserviceable.

041103. Using the appropriate adjustment transaction, units will drop from the property records flags and battle standards that are disposed of.

A. The adjustment document will contain the statement, “This Flag/Standard does not contain any historical value and is beyond economical repair.”

B. The following certification will appear on the adjustment document: “I certify that on this date I have burned the Flag/Standard appearing on this adjustment document.”

0412 GAS CYLINDERS AND VAPOR FUELS

Gas cylinders, whether filled or empty, will be accounted for in an APSR under the applicable stock numbers and unit price for empty cylinders using sub-custody procedures established in Chapter 2 of this Volume. The contents of the cylinders will be carried under the applicable stock numbers and unit price. Cylinders may be designated as locally controlled items. For additional information, see reference (az).

0413 RADIOLOGICAL AND HAZARDOUS ITEMS

Radiological/hazardous items will be controlled, stored, disposed of, and replaced when lost or stolen per all pertinent technical and special instructions.

0414 TRANSFER OF PROPERTY TO FOREIGN GOVERNMENTS

At the time the transfer authority is provided, DC I&L (LP) will furnish separate accounting instructions for the transfer of Marine Corps property to foreign governments.

0415 SALES OF GOVERNMENT PROPERTY

While the sale of government property is not a retail-level supply function, certain retail-level activities still perform this function (e.g., MARFORRES units). The following guidance is provided:

041501. Items Authorized for Sale

The following government property may be sold to eligible patrons under the provisions and within the limitations outlined:

- A. Uniform clothing.
- B. Cloth for the manufacture of uniform clothing.
- C. Housekeeping supplies.

- D. Industrial safety goggles.
- E. Protective footwear.
- F. Heating and cooking fuel.
- G. Suitcases, trunk lockers, and Marine Corps NCO swords.
- H. Stationery and envelopes.
- I. Utility items and services (including steam, gas, electricity, water, refrigeration, sewage disposal, telephone, laundry, and dry-cleaning services).
- J. Forage and veterinary services.
- K. Gasoline, diesel fuel, motor oil, and lubricants.
- M. Wall plaque, USMC.
- N. Service belt.

041502. Authorized Patrons

Government property may be sold to the following authorized patrons:

- A. Officers and enlisted personnel (active duty and retired) of the Army, Navy, Marine Corps, Coast Guard, and Air Force.
- B. Officers of the public health service, active and retired.
- C. Commissioned officers, ships officers, and crew members of the Coast and Geodetic Survey.
- D. Civilians who are part of an expeditionary force sent to a foreign country.
- E. Commercial firms (approved uniform manufacturers or their respective distributors) under the following circumstances:

1. Uniform materials stocked by the Marine Corps will be sold to approved manufacturers of officer's uniforms only when materials, as approved by MARCORLOGCOM, are not available from approved commercial sources.

2. When approved materials are not available from approved commercial sources, requests must include a statement of intended use (e.g., used in the manufacture of the Marine Corps officer blue dress uniform USMC Serial Number____).

13 JUN 2016

3. Credit may be extended for the purchase of uniform materials or findings by commercial firms. Subsequent to shipment of requested materiel or findings, payment for the entire purchase shall be made in cash or its equivalent within 60 calendar days.

F. When not on active duty, officers of the Marine Corps Reserve and Navy may be permitted to purchase articles of clothing required when ordered to active duty. Such officers may also purchase items of equipment not issued to officers under current allowance lists but are required for active duty.

G. Active duty enlisted personnel of the Marine Corps Reserve and Navy Reserve will be limited to articles and quantities required by the reservists for their personal use. Enlisted personnel of the Marine Corps Reserve in an inactive status may be permitted to purchase articles of uniform equipment for their personal use, as authorized by DC I&L (LP).

H. Marine Corps Junior Reserve Officer Training Corps cadets may purchase individual uniform clothing items as authorized. All cash sales of uniform clothing items will be made per the instructions contained in reference (bm).

041503. Disabled Veterans

Honorably discharged veterans of the armed services who are totally disabled, as determined by the Department of Veterans Affairs (VA), are being cared for and are receiving medical treatment from the VA, but who are not in retired status, are permitted to purchase authorized Marine Corps supplies while undergoing care and treatment. Totally disabled veterans, not in retired status, receiving medical care and treatment as an occasional outpatient service, but gainfully employed, do not qualify.

041504. Former Marines

Former members of the Marine Corps who are separated under honorable conditions may purchase exterior articles of uniform once evidence of honorable discharge is provided to the Clothing Sales Stores of the Marine Corps Exchange. Marine Corps dress blue uniform articles may be sold to spouses of deceased former Marines in the amount necessary for interment of the body. See Volume 13 of this Order.

041505. Authorized Activities

Sales may be made to Marine Corps Exchanges, recreation funds, officer's messes (open and closed), SNCO clubs, NCO clubs, enlisted clubs, temporary lodging facility, and American Red Cross facilities upon approval of the CO concerned; however, supplies for resale will not be sold to such organizations except when authorized by DC I&L (LP).

041506. Exception for Disabled Veterans

As an exception to paragraph 141502 above, honorably discharged veterans of the uniformed services with 100 percent service-connected physical disability may be authorized to purchase merchandise in commissary stores. In this instance, the requirements for medical care, treatment, and gainful employment do not apply.

041507. Prices to be Charged

Prices established by Marine Corps pricing publications and the Federal Logistics Data database will apply for all purposes. For property not covered by Marine Corps pricing publications, the last invoice or purchase price will govern.

041508. Surcharges

No surcharge will be applied on sales made under the authority of this policy.

041509. Limitations

A. General Restrictions

Articles of government property falling within any of the categories in paragraph 141508 above, may be sold in limited quantities to eligible patrons under the following conditions:

1. The items are intended for use by the authorized purchaser.
2. Sufficient stocks exist to satisfy demands and to permit sales.
3. The sale is not prohibited by specific restrictions set forth in the following

paragraph.

B. Specific Restrictions

1. Uniform clothing may only be sold to patrons authorized to have uniform clothing in their possession, or to dependents (next of kin for unmarried deceased former Marines) acting as agents for Marine Corps officers and enlisted.

2. Cloth for the manufacture of uniform clothing may be sold to officers, SNCOs, and commercial firms under certain conditions.

3. Housekeeping supplies, including brooms, mops, soap, and similar items may be sold subject to the following restrictions:

- a. Overseas Stations. Sales to authorized patrons are permitted.

13 JUN 2016

b. United States activities, except in the states of Alaska and Hawaii.

Sales of housekeeping supplies will not be made within the contiguous limits of the United States, except by specific authority of the DC I&L (LF). Requests for such sales will originate from the unit CO and must state that similar items are not available from local commercial sources at reasonable prices.

c. Marine Corps Exchanges, Temporary Lodging Facility, and similar activities. Sales of housekeeping supplies may be made to commissioned officer's messes, SNCO clubs, NCO clubs, enlisted clubs, temporary lodging facility, Marine Corps Exchanges, and like organizations.

4. Heating and cooking fuel may only be sold to government-sponsored non-appropriated fund activities; occupants of government-owned rental housing, including trailers; and owners of private trailers located in government-owned on-station trailer parks. Sales may be made in bulk to the program manager or directly to individual tenants.

5. Authorized items of individual equipment required in the performance of duties may be sold to Marine Corps officers and enlisted and to officers and enlisted personnel of other branches of the military services when attached to the Marine Corps. The Marine Corps NCO sword and scabbard are authorized to be sold to Marine Corps enlisted only if required in the performance of duties.

6. Stationery and envelopes may be sold only to Marine Corps Exchanges, temporary lodging facility, commissioned officers messes, SNCO clubs, NCO clubs, enlisted clubs, and other like organizations.

7. Forage and veterinary services may be sold when incidental to the care of private mounts or animals owned by recreational activities when such animals are stabled in a government stable or corral.

8. Sales of subsistence items will be made only as authorized by reference (be).

9. Sales of gasoline, diesel fuel, motor oils, and lubricants will be made only to government-sponsored non-appropriated fund activities.

10. Sales of the USMC wall plaques may be made to civilian activities and individuals when specifically authorized by the DC I&L (LP).

11. Sales of the service belt will be made only to those Marine Corps personnel authorized by reference (bn).

041510. Replacement Sales

The foregoing restrictions will not preclude the sale of items of government property to an individual for the purpose of voluntarily replacing items determined to have been lost, damaged, or

destroyed by the person; however, COs will ensure that this provision is not used as a way to purchase items, the sale of which is otherwise restricted.

041511. Specific Prohibition

The sale of any articles of government property not addressed in paragraphs 041501 through 041510 above is prohibited.

041512. Disposition of Sales Proceeds

Except as otherwise authorized in Volume 5 (Disbursing Policy) of reference (e), sales proceeds of government property will be delivered to the disbursing officer or appropriately deposited.

041513. Individual Clothing

Specific instructions governing proceeds of sales by individual clothing outlets are in Volume 13 of this Order and as outlined in this policy.

0416 SALES OF INDIVIDUAL EQUIPMENT TO INDIVIDUAL MARINES

041601. Information

A. The sale of individual equipment and linen to individual Marines for the in-kind replacement of lost, damaged, or destroyed equipment is authorized. Sales will be voluntary in nature. Those items lost, damaged, or destroyed through normal usage or operational circumstances will continue to be budgeted for and managed by using units through O&M,MC and O&M,MCR funding.

B. Individual equipment purchased for personal use is not required to be entered in the recipient's qualification record or service record book.

041602. Supported Unit Responsibilities and Procedures

Supported unit responsibilities and procedures are covered in Volume 4 of this Order. Volume 4 of this Order also provides policy pertaining to the acceptance of responsibility for loss, damage, or destruction of government property.

041603. Establishment/Disestablishment of Sales

Commands wishing to establish or cease the sale of individual equipment to individual Marines will request authority from DC I&L (LP).

0417 PROPERTY ISSUED FOR USE OF THE GUARD

Property used by guard units will be issued and controlled as follows:

041701. General Information

Units will issue such property to a designated RO.

041702. Guard List

Designated ROs of units maintaining guard sections will prepare a list of all articles issued for use by the guard. The list will include certification that the property listed is in the hands of the guard. Prior to assuming the duties and responsibilities as sergeant of the guard, the sergeant of the guard will inventory and document the receipt of property in the guard book as follows: "Property on charge to the guard is correct" or "Property on charge to the guard is correct with the following exceptions (naming the missing articles)."

041703. Weapons

Units will list by serial number all weapons and other nonexpendable end items. No changes will be made to the list except by the designated RO. If changes are required, the RO will initial all changes as they are made.

041704. Procedures

The guard property list will be kept in a convenient place in the guard room. In the event the sergeant of the guard notes a discrepancy when receipting for property, the responsibility will rest with the sergeant turning over the property. The sergeant of the guard will immediately notify the designated RO so that proper action can be taken to obtain a replacement.

0418 PAINTINGS

041801. Accountability

Original paintings and copies of original paintings procured with appropriated or non-appropriated funds or by donation will be accounted for on Marine Corps base, post, or station property records for inventory purposes only. Lithograph reproductions of paintings are not copies of original paintings and will not be accounted for.

041802. Exceptions

Original paintings and copies of original paintings purchased with officer mess funds, enlisted dining facility funds, or club funds or donated to such messes or clubs will be carried on mess or club property accounts.

041803. On Loan

Original paintings and copies of original paintings received as a loan from organizations or individuals will not be taken up on accounts or property records, subject to any controls imposed by the lender or CO.

0419 THE OFFICIAL MARINE CORPS SEAL AND EMBLEM

041901. Background

The symbolic significance and dignity of the official Marine Corps Seal requires complete uniformity in its design, coloration, and reproduction for official use. Presidential Executive Order 10538 of 22 June 1954 established the basic design of the official Seal of the United States Marine Corps.

041902. The Official Marine Corps Seal

A. The official Marine Corps Seal, hand impression, will be used to authenticate official records of the Marine Corps. Official records or copies of the Marine Corps Seal are authorized to be produced in response to a court order or per the request of personal representatives of personnel in the Marine Corps. Requests may be authenticated by an attesting certificate under the official Seal of the Marine Corps.

B. The official Marine Corps Seal will be issued to Marine Corps bases, posts, stations, organizations, activities, and units whose duties require use of the seal. Except in the case of separate or detached commands, the official Marine Corps Seal will not be issued to OPFOR organizations smaller than a battalion or squadron.

C. Marine Corps units that require the official Seal, hand impression, lettered, "Department of the Navy - United States Marine Corps," with insignia of the United States Marine Corps (TAMCN C6030, NSN 7520-00-269-8773), shall submit requisitions to MARCORLOGCOM.

D. Due to the historical background, significance, and dignity of the official Marine Corps Seal and its use, Marine Corps activities authorized possession of the official Seal, will designate a custodian in writing. The CO will establish rules necessary for proper safekeeping and use.

E. Per reference (ad), upon disestablishment of an activity or whenever an official Marine Corps Seal is excess to the needs of a command, the unit will report the quantity held to MARCORLOGCOM.

041903. Bronze Replica of the Marine Corps Seal

A. DC I&L (LF) will approve the procurement of official Marine Corps Seal replicas, cast in bronze and 15 inches in diameter, for use as entrance markers on main gates and official administration buildings of Marine Corps installations. Replicas may also be erected and dedicated on a military post or station for use on military service monuments.

B. Upon disestablishment of an activity or whenever excess to the needs of the command, units will request disposition instructions from DC I&L (LF).

C. Units will not sell or give bronze replicas of the Marine Corps Seal to private individuals or organizations.

041904. Wall Plaque Replica of the Marine Corps Seal

Wall plaque replicas of the official Marine Corps Seal, suitable for indoor use (NSN 9905-00-912-3089), are standard items of supply and are authorized for issue to Marine Corps activities.

- A. Marine Corps activities will submit requisitions to MARCORLOGCOM.
- B. Active duty, reserve, and retired Marine Corps personnel that wish to purchase wall plaques must send requests via a NAVMC 10710, "Individual Clothing Request" to MARCORLOGCOM.
- C. Individuals, other military and civilian activities not included in paragraphs 041904.A and 041904.B above should request wall plaques from DC I&L (LP).

041905. Bronze Replicas of the Marine Corps Emblem

DC I&L (LF) may approve replicas of the official Marine Corps emblem (eagle, globe, and anchor, without inscription), cast in bronze, 15 inches in diameter, for use as markers on main gates such as nonmilitary cemeteries and on nonmilitary-dedicated monuments to the military service. Replicas may also be approved for use under circumstances that will conform to good taste and propriety and not reflect unfavorably on the Marine Corps or its personnel. Non-Marine Corps activities or individuals will submit requests to DC I&L (LF). Upon approval, purchasers will be authorized to place orders directly with the specified manufacturer. Headquarters Marine Corps will authorize the manufacturer to honor the purchase order.

041906. Printing Reproduction and Use

- A. Reference (bd) provides general rules regulating the printing, reproduction, and use of the official Marine Corps Seal and emblem.
- B. Reference (bo) provides policy for the use of reproductions of the Marine Corps emblem on merchandise sold in the Marine Corps Exchange.

0420 PERSONAL RETENTION ITEMS

Personal retention items are select items that are unhygienic to recover from an individual following use (i.e., clothing items that are worn close to the body) and thereby designed for permanent issue. Volume 13 of this Order identifies personal retention items. In accordance with the guidance and conditions in references (at) and (bp), units will issue personal retention items. Issues will be made via a signed receipt, which is the basis for an entry in the individual's qualification record or service record book. Upon reenlistment, this entry will be transcribed into the new service record book. Per CO's discretion, when warranted, and if unit funds are available, unit personnel may exchange unserviceable or obsolete personal retention items (i.e., one for one replacement).

0421 GENERAL OFFICER'S STATIONERY ITEMS

As authorized in Marine Corps SL-8-09993, Marine Corps organizations that require stationery for use by general officers on active duty in the conduct of official U.S. Marine Corps social functions, will submit requisitions to the local Navy Printing and Publication Office. For uses other than this, units may obtain general officer's stationery by contacting the MARCORLOGCOM.

0422 ORGANIZATIONAL CLOTHING AND EQUIPMENT

Organizational clothing and equipment includes items on an organization's allowance list designed for temporary issue to individuals, and T/E or other items that HQMC approves in writing through the UNS or other designated process. Refer to Volume 13 of this Order for additional information regarding organization clothing and equipment.

042201. Procurement

The initial procurement, replacement, and maintenance of these items will be accomplished with local O&M, MC or O&M, MCR funds.

042202. Accounting

As long as allowances are established, COs may issue organizational clothing or equipment as necessary for mission accomplishment. Whenever possible, a central facility such as an Individual Issue Facility (IIF) or other authorized consolidated issue facility/organization should consolidate allowances and maintain items. Per this policy, clothing articles issued under this authorization will be accounted for as nonexpendable items.

042203. Laundry

With the exception of campaign covers, units will use O&M, MC or O&M, MCR funds to execute laundry services for organizational clothing.

042204. Recovery

Unless otherwise directed by DC I&L (LP), all articles, with the exception of campaign service covers and personal retention items, will be recovered prior to the reassignment of an individual to other duties. Recovered clothing will be processed for reissue or disposal in the best interest of the government.

042205. Campaign Service Covers

A. Authorized Wear

Reference (bn) lists individuals authorized to wear campaign service covers.

B. Accountability

Marines assigned to the billet of drill instructor or primary marksmanship instructor will be issued three campaign covers. Campaign covers will be accounted for as nonexpendable items and will be issued on custody records until completion of a tour of duty as follows:

1. Units will not recover campaign covers from Marines that complete a successful tour as a drill instructor or primary marksmanship instructor.

a. Units will annotate the check-out sheet with the document number for the issue and drop of campaign covers from the property records.

b. In accordance with paragraph 0210 of Chapter 2 in this Volume, units will maintain a record of all issues and drops.

2. Units will recover and dispose of all three campaign covers from a Marine who does not complete a successful tour as a drill instructor or primary marksmanship instructor due to cause, fault, or negligence.

a. Units will place an entry of the issue in the Marine's Service Record Book (SRB).

b. The SRB entry will state "Three campaign covers were recovered on (date) due to relief from duty for cause, fault or negligence."

c. A record of the above SRB entry will be cited on the unit's check-out sheet for use by the clothing or property control officer to recover the campaign covers.

d. In addition, the personnel officer will forward an advance copy of the SRB entry to the clothing or property control officer to ensure recovery of campaign covers take place.

3. Costs associated with maintaining the campaign cover will be at the individual's expense; however, units will replace covers that become unserviceable due to normal wear (no negligence by the individual).

042206. Aiguilletes

An allowance is established of one dress aiguillette and two service aiguilletes per Marine officer detailed to duty as outlined in reference (bn). They will be procured and accounted for as follows:

A. The supply officer of the organization to which the aide is attached will procure aiguilletes from an approved commercial source as identified by the local Marine Corps Exchange Service. The activity to which the aide is attached will furnish funds for the procurement.

B. The Marine Corps Exchange Service publication titled "Approved Sources of Marine Corps Uniforms" lists approved sources.

C. Marine Corps activities that procure aiguillettes will account for aiguillettes as organizational property or clothing.

D. Staff Commands

The flag or staff activity to which Marine officers are detailed for duty as aides to flag officers and/or naval attaches will normally furnish aiguillettes. The activity to which officers from other services are detailed for duty as aides to a Marine general officer will furnish aiguillettes.

042207. Marking

At the discretion of the organization CO, the marking of organizational clothing and equipment is permitted as long as the marking is not permanent and does not damage or degrade the combat effectiveness of the item. Exceptions are as follow:

A. To identify organizational clothing or equipment as government-owned property and to segregate IIF clothing from personally owned clothing or equipment, authorized CSP staff personnel may permanently mark organizational clothing or equipment as long as the mark does not damage or degrade the combat effectiveness of the clothing or equipment.

B. At their own cost, individuals may permanently mark items issued as personal retention items (see paragraph 1419 in this chapter).

0423 ANIMALS

042301. General Equipment includes animals that are used in the performance of military missions. Units will carry animals on the property records as nonexpendable property. Required formal accounting records will establish an audit trail recording receipt and disposal transactions for each animal.

042302. References (bq) and (br) contain policy and guidance for Marine Corps Military Working Dogs and provide specific guidance on the procurement and handling of both explosive and narcotics training aids.

0424 LOAN OF PROPERTY TO NON-GOVERNMENT ORGANIZATIONS (NGOS)

042401. Policy

Title 10 U.S.C. 2544 authorizes OSD to lend certain equipment to NGOs, per references (i) and (bs). This statute also authorizes OSD, without reimbursement, to furnish services and expendable medical supplies as may be necessary or useful, provided that the items are in stock and the items or services are available.

042402. General Provisions

A. The Secretary of the Army is the designated representative of OSD in entering into arrangements with NGOs for these services. The Marine Corps will cooperate with the Department of the Army in furnishing necessary equipment and services where available and when requested.

B. Tents, cots, blankets, commissary equipment, flags, refrigerators, and other equipment as may be necessary or useful, provided such items are in stock and available, may be loaned to NGOs. Such loans will not jeopardize Marine Corps operations or commitments.

042403. Procedures

A. The equipment is authorized to be delivered prior to the requirement and will be returned after the completion of the requirement as agreed upon by the Secretary of the Army or the secretary's designee and the NGO. The NGO shall pay for the delivery, return, rehabilitation, or replacement of such equipment. No expense shall be incurred by the United States Government.

B. Sufficient bond shall be obtained from the NGO before furnishing the equipment, property, or transportation authorized. The bond is to assure the safe return of such property in good condition and the reimbursement of actual transportation costs.

C. Refer to Volume 10 of this Order for additional information regarding external temporary loan procedures.

0425 MATERIEL WITHOUT TABLE OF ORGANIZATION & EQUIPMENT ALLOWANCES

For categories of materiel without TO&E allowances, the pertinent Navy and Marine Corps directives and SLs list amplifying allowance instructions (see Figure 4-1).

MATERIEL	REFERENCE
Aeronautical Supplies	OPNAVINST 4441.12D
Individual Clothing	MCO 4400.201 Volume 13
Competition Rifles and Pistols/Ammunition	MCO 8373.2E
Junior Reserve Officer Training Corps (JROTC) Schools	MCO 1533.6E
Medical Controlled Substances	BUMEDINST 6710.70A
Heraldic Items	MCO P10570.1B

Figure 4-1.--Materiel Without TO&E Allowances.

0426 INITIAL ISSUE PROVISIONING (IIP)

042601. General Information

Before new equipment is placed in service, the IIP process identifies, selects, acquisitions, and provides instructions for the positioning of necessary initial support items at appropriate segments of the supply system and levels of maintenance. Until the supply system has supply and maintenance usage history for initial support items to accurately forecast and provide sustained

support, IIP will provide the unit with sufficient inventory of repair parts, special tools, and special equipment.

042602. Accounting Policy

Until the MEF or MARFORRES Commander authorizes and notifies in writing to place items into service, IIP will not release the initial operating stocks to units. Units that are not authorized to store initial operating stocks will return the initial operating stocks to the supporting logistics combat element (LCE) (i.e., SMU and RIP). IIP will provide the unit with equipment-specific information to include procedures concerning repair parts. Reference (b) further addresses provisioning policy.

042603. Demand Development Period

After IIP releases the initial operating stocks to the supporting LCE, a demand development period will begin and continue for a minimum of two years to allow for the accumulation of historical demand and maintenance data. The demand development period helps prevent premature redistribution or reutilization of initial operating stock based upon insufficient historical demand data. The supporting LCE will establish a minimum stockage objective based upon the total quantity of initial operating stock released. During the demand development period, the supporting LCE may not reduce the minimum stockage objective; however, it may increase the minimum stockage objective as needed to meet increases in demand for the support item. The supporting LCE may issue initial operating stock to fulfill the supported unit's requisitions and generate historical demand. Upon expiration of the demand development period, the supporting LCE may adjust the stockage objective to the most applicable level or extend the demand development period for an additional year to capture additional usage.

VOLUME 3: APPENDIX A

**“SUPPLY OFFICER/ACCOUNTABLE PROPERTY OFFICER
APPOINTMENT LETTER FORMAT”**

SUMMARY OF SUBSTANTIVE CHANGES

All changes are denoted by **blue font** unless a full revision has been conducted.

Hyperlinks are denoted by ***bold, italic, blue and underlined font.***

Base date of this Marine Corps Order (MCO) Volume (right header) will not change unless a full revision has been conducted. Upon full revision of this Volume, all changes denoted by blue font will reset to black font.

PAGE PARAGRAPH	EXPLANATION OF SUBSTANTIVE CHANGES	PURPOSE	DATE OF CHANGE

APPENDIX A

SUPPLY OFFICER / ACCOUNTABLE PROPERTY OFFICER APPOINTMENT LETTER
FORMAT

The example format below includes all the inherent roles of a Supply Officer/Accountable Property Officer (APO) in accordance with this policy. In some instances, the Supply Officer/APO may not be assigned all the roles indicated in the example. In these situations, the paragraphs will be excluded from the appointment letter and will be used in a separate CO appointment letter to appoint the appropriate individual. Additionally, certain roles may be delegated to other individuals based on recommendations from the Supply Officer/APO. In these situations, the appropriate paragraph will be used in a separate CO appointment letter to appoint the appropriate individual the delegated responsibilities.

4400
(code)
(Date)

From: Commanding Officer

To: (Rank First Name MI. Last Name)

Subj: APPOINTMENT AS SUPPLY OFFICER/ACCOUNTABLE PROPERTY
OFFICER

Ref: (a) DoD 7000.14-R
(b) NAVSUPINST 4200.99
(c) MCO 4400.201 Volume 3
(d) Local GCPC guidance

Encl: (1) DD 577

1. Per the references, you are appointed as the unit Supply Officer/APO for (add unit name), Department of Defense Activity Code (DoDAAC)/Unit Identification Code (UIC): (add DoDAAC(s))/(add UIC(s)). You are a special staff officer and are directed to comply with the references and other applicable directions in the performance of your duties and responsibilities.
2. Prior to your acceptance of this account, but no later than (enter date), you must complete an inventory of all property and equipment belonging to your DoDAAC/UIC and report the findings to me with recommendations for any actions that need to be taken to accurately record the inventory results. (NOTE-this will be as an endorsement to the outgoing Supply Officer Certificate of Relief).
3. You are responsible for the property accounting functions for the command and are responsible for ensuring the accounting systems and records are accurate and updated at all times. In addition to properly receiving, accepting, and accounting for all government property received by the command, you will ensure the follow allowance item management principals are applied.

13 JUN 2016

a. On a monthly basis, validate allowance item information (e.g., TAMCNs, NSN/NIINs, nomenclature, authorized quantities, etc.) on the unit's Table of Organization and Equipment as accurate and properly recorded on the unit's supply APSR.

b. Account for equipment that is issued or signed out to Responsible Officers, individuals, and/or other units and maintain the permanent record of custody for such equipment.

c. Ensure that physical inventories are being conducted as required (e.g., annual, quarterly CMRs/CARs, RO turnovers, etc.) and that accountable records are being adjusted accordingly.

d. Track monthly inventories of small arms and report to me when monthly inventories of small arms are not conducted. Ensure account and custody records are being adjusted accordingly, and weapons reporting procedures are being followed.

e. Achieve and maintain a minimum physical inventory accuracy rate (to the serial number for serialized items) of 98 percent (100 percent for classified or sensitive property).

f. Maintain assigned equipment in a ready-for-use and serviceable condition.

4. Serve as the unit Fiscal/Budget & Accounting Officer for DoDAAC/UIC (add DoDAAC(s)/add UIC(s)). You are responsible for the management of the command's financial resources allocated in the Standard Accounting Budgeting and Reporting System (SABRS) under Work Center Identification (WCI): (enter applicable WCI), Budget Execution Activity (BEA): (enter applicable BEA(s)), Budget Execution Sub-Activity (BESA): (enter applicable BESA(s)). Your specific duties include:

a. Fund Holder internal management control oversight.

b. Provide guidance and direction of financial matters throughout the organization as a staff service to me.

c. Track all activities/programs that will have a financial impact on the organization. This will include budget plans and program schedules.

d. Perform applicable budget formulation, execution, and review functions for future, current, and expired fiscal years.

e. Provide guidance to fund holders responsible for the administration of travel payments (i.e., advances and settlements).

f. Ensure budget authorizations and allotments are passed to subordinate elements in a timely manner, if applicable.

g. Maintain oversight of transactions posted in the accounting system to ensure validity and accuracy of postings. These evaluations should include proper usage of funds, coding structures used, validity of obligations, and timely posting of financial information.

13 JUN 2016

h. Conduct evaluations and analyses of fund holder activities to assist in the prompt detection and correction of problems in connection with established financial procedures, practices, records and accounting system problems and deficiencies.

i. Ensure proper records and source documents supporting fund execution are maintained by appropriate activities such as fund holders.

j. Ensure proper use of appropriations by purpose, time, and amount to include meeting the criteria of bona-fide need.

k. Train delegated fund holders in the proper utilization of the accounting system.

l. Act as a liaison with DFAS on all accounting issues.

m. Maintain required currency in fiscal training.

5. Serve as the unit Supply Resource Manager for DoDAAC/UIC (add DoDAAC(s)/add UIC(s)). You will receive allocated funds in SABRS under WCI: (enter applicable WCI), BEA: (enter applicable BEA(s)), BESA: (enter applicable BESA(s)) as a resource to accomplish and execute your mission. Your specific duties include:

a. Execution of unit requisition management.

(1) Maintain all document numbers for the command's DoDAAC(s) used for requisitioning.

(2) Prepare requisitions and source documents.

(3) Ensure compliance with the Uniform Movement and Issue Priority System (UMMIPS).

(4) Induction of requisitions into the supply system.

(5) Retaining of requisition records.

(6) Maintain requisition status information.

(7) Ensure that available stock is issued (if authorized and held) before induction of requisitions into the supply system (except replenishment action).

(8) Follow up and/or conduct causative research on outstanding requisitions.

(9) Modify existing requisitions, when appropriate.

(10) Process cancellations, when appropriate.

(11) Process receipts, when appropriate.

(12) Make liaison with supply activities providing support to the unit for any additional action required.

(13) Ensure appropriate fiscal transactions process correctly.

(14) Manage related reports.

b. Recommend Fund Holder assignments and provide Fund Holder oversight for preparing source documents, ensuring the proper assignment of funding on an obligation document before the obligation is incurred.

c. Compile and execute the budget in accordance with the financial plan for the current fiscal year.

d. Monitor the execution of the financial plan for all fiscal years available for obligation.

e. Reconcile the accounting system with source documents on a cyclic basis.

f. Maintain financial records and source documents in accordance with the references.

g. Identify and provide information to the comptroller on Unmatched Disbursements (UMDs) and Negative Unliquidated Obligations (NULO) on error and exception listings.

h. Conduct Unliquidated Orders and Outstanding Travel Orders validations.

6. Serve as a Certifying Officer for DoDAAC/UIC (add DoDAAC(s)/add UIC(s)). You will promptly certify vouchers for payment in SABRS under WCI: (enter applicable WCI), BEA: (enter applicable BEA(s)), BESA: (enter applicable BESA(s)). Your specific duties include:

a. Provide oversight to Departmental Accountable Officials (DAOs) (i.e., Responsible Officers, Resource Manager/Fund Holders) to strengthen internal controls.

b. Ensure proper preparation of all source documents and availability of funds prior to certifying payment.

7. Serve as the GCPC Approving Official for DoDAAC/UIC (add DoDAAC(s)/add UIC(s)). Funding will be allocated to you for execution in SABRS from WCI: (enter applicable WCI), BEA: (enter applicable BEA(s)), BESA: (enter applicable BESA(s)). Your specific duties include:

a. Execute your duties in accordance with reference (a), applicable DON/USMC policies and procedures, NAVSUPINST, 4200.99, and locally established program operating procedures.

b. Provide oversight for appointed GCPC cardholders (CHs) in your hierarchy, frequently reviewing all available information in order to promptly identify improper use.

c. Ensure timely and accurate processing of monthly billing statements and updates of the cardholder's automated system, if applicable.

13 JUN 2016

d. Ensure assigned GCPC CHs are adequately controlling access to their card to preclude unauthorized use.

e. Serve as the certifying officer for the accounts assigned.

8. Serve as the Supply Automated Information System (AIS) Administrator responsible for approving command access to automated system(s) used to support the purchase request, requisitioning, receipt and acceptance, equipment accountability, financial management, and other supply chain management systems. Your specific duties include:

a. Approving System Authorization Access Requests (SAARs) in order to grant access to these systems for an activity.

b. If required, recommend the appointment of additional Supply AIS administrators to assist in the performance of these duties.

9. Recommend to me which personnel should be delegated, in writing, with the following roles on behalf of the command and ensure the appointments are maintained current on file: Supply Resource Manager (if not appointed), Fiscal/Budget & Accounting Officer (if not appointed and in absence of a unit comptroller), Certifying Officer, GCPC Approving Official (if not appointed), Supply AIS Administrator (if not appointed), GCPC CHs, Fund Holders, Receipt & Acceptors, and Responsible Officers.

10. This letter supersedes all previous letters and will remain in effect until revocation or reassignment.

(Signature)
(FI. MI. LAST Name of CO)

VOLUME 3: APPENDIX B

**RESPONSIBLE OFFICER/PROPERTY CUSTODIAN APPOINTMENT
LETTER FORMAT**

All changes are denoted by **blue font** unless a full revision has been conducted.

Hyperlinks are denoted by ***bold, italic, blue and underlined font***.

Base date of this Marine Corps Order (MCO) Volume (right header) will not change unless a full revision has been conducted. Upon full revision of this Volume, all changes denoted by blue font will reset to black font.

PAGE PARAGRAPH	EXPLANATION OF SUBSTANTIVE CHANGES	PURPOSE	DATE OF CHANGE

APPENDIX B

RESPONSIBLE OFFICER / PROPERTY CUSTODIAN APPOINTMENT LETTER
FORMAT

Below is an example format of the Responsible Officer appointment letter and COs have the discretion to modify accordingly; however, the content of the example is the minimum requirements that will be used in all appointments.

4400
(code)
(Date)

From: Commanding Officer

To: (Rank First Name MI. Last Name)

Subj: APPOINTMENT AS RESPONSIBLE OFFICER / PROPERTY CUSTODIAN

Ref: (a) DoD 7000.14-R

(b) MCO 4400.201 Volume 3

Encl: (1) Consolidated Memorandum Receipt

1. Per the references, you are appointed as the Responsible Officer/Property Custodian for (*add unit name*), Department of Defense Activity Code (DoDAAC)/Unit Identification Code (UIC)/ Consolidated Memorandum Receipt (CMR)/ Custodian Asset Report (CAR) account: (*add DoDAAC*)/(*add UIC*)/(*add CMR/CAR account*). You are directed to comply with the references and other applicable directions in the performance of your duties and responsibilities.

2. You will receive allocated funds in the Standard Accounting Budgeting and Reporting System (SABRS) under Work Center Identification (WCI): (*enter applicable WCI*), Budget Execution Activity (BEA): (*enter applicable BEA(s)*), Budget Execution Sub-Activity (BESA): (*enter applicable BESA(s)*) as a resource to accomplish and execute your mission.

3. Prior to your acceptance of this account, but no later than (*enter date*), you must complete an inventory of all assigned equipment and return the CMR/CAR with the results of your inventory to me via the Supply Officer/Accountable Property Officer (APO). You must reconcile with the Supply Officer prior to the deadline and report the status of your account through endorsement of this letter. Your endorsement will be your formal acceptance of the CMR/CAR account, with or without identified discrepancies.

4. As indicated in the references, you responsibilities include:

a. Assume responsibility for resources (financial and property) assigned to you for mission accomplishment. These resources are issued from the supply office in the performance your regular duties and will be properly accounted for within your span of control.

13 JUN 2016

b. Receipt for all equipment on-hand, ensuring the CMR/CAR identifies equipment by Marine Corps or manufacturer's serial number, when applicable, and ensure parent-child relationships are maintained within the Installed Base.

c. Maintain assigned equipment in a ready-for-use and serviceable condition in accordance with the applicable equipment's supporting technical manuals and Stock List publications.

d. Enforce a clear chain of custody for all equipment and always sub-custody equipment to others before allowing it to leave your area of responsibility. Any temporary loans outside of the command must be authorized by S-3, coordinated by S-4 and executed via Supply.

e. Report all changes of the accounting records to the Supply Officer as they occur.

f. Report all discrepancies to the supply officer in writing that exist between the CMR/CAR and what is actually on hand, and fully state the circumstances of each discrepancy.

g. Request necessary investigative action in writing, for CMR/CAR discrepancies resulting from a known loss, damage, or destruction of government property, to me via the Supply Officer in accordance with the references.

h. Conduct physical inventories of all assigned equipment and reconcile the account with the Supply Officer on a quarterly basis.

i. Delegate in writing, via a NAVMC 11869, the individuals who will perform the following duties:

(1) Receipt for Equipment, Supplies and/or Services

(2) Submit/Sign Purchase Requests

(3) Turn-in excess or damaged government property

j. You may and are encouraged to appoint Responsible Individuals (RI) to assist in your property accountability responsibilities. RIs are subcustody holders of accountable supplies, originally signed for by you. They are appointed by you in writing and will sign for all supplies within their possession. Delegation of accounting responsibilities to a RI does not relieve the RO of accountability.

5. Prior to being relieved as the RO, you must request a change of RO from the Supply Officer and conduct a joint inventory no less than 30 calendar days prior to your date of relief. The account must be transferred prior to your transfer from the command. Additionally, if you anticipate being separated from your property in excess of 60 calendar days, a new RO will be appointed and a joint inventory conducted.

(Signature)
(FI. MI. LAST Name of CO)

VOLUME 3: APPENDIX C

FUND HOLDER APPOINTMENT LETTER FORMAT

All changes are denoted by **blue font** unless a full revision has been conducted.

Hyperlinks are denoted by ***bold, italic, blue and underlined font***.

Base date of this Marine Corps Order (MCO) Volume (right header) will not change unless a full revision has been conducted. Upon full revision of this Volume, all changes denoted by blue font will reset to black font.

PAGE PARAGRAPH	EXPLANATION OF SUBSTANTIVE CHANGES	PURPOSE	DATE OF CHANGE

APPENDIX C

FUND HOLDER APPOINTMENT LETTER FORMAT

Below is an example format of the Fund Holder appointment letter and COs have the discretion to modify accordingly; however, the content of the example is the minimum requirements that will be used in all appointments.

4400
(code)
(Date)

From: Commanding Officer
To: (Rank First Name MI. Last Name)

Subj: APPOINTMENT AS FUND HOLDER

Ref: (a) DoD 7000.14-R
(b) MCO 4400.201 Volume 3

1. Per the references, you are appointed as a Fund Holder for *(add unit name)*, Department of Defense Activity Code (DoDAAC)/Unit Identification Code (UIC): *(add DoDAAC)/(add UIC)*). You are directed to comply with the references and other applicable directions in the performance of your duties and responsibilities.
2. You will be responsible to the Supply Resource Manager for the proper assignment of funding on obligation documents before obligations are incurred and for maintaining a system of positive funds control in the Standard Accounting Budgeting and Reporting System (SABRS) for Work Center Identification (WCI): *(enter applicable WCI)*, Budget Execution Activity (BEA): *(enter applicable BEA(s))*, Budget Execution Sub-Activity (BESA): *(enter applicable BESA(s))*.
3. As indicated in the references, your responsibilities include:
 - a. Ensure proper preparation of requisitioning source documents.
 - b. Accurately record accounting transactions in the appropriate accounting system.
 - c. Conduct reconciliations with the accounting system and source documents on a regular basis.
 - d. Maintain appropriate financial records and source documents.

(Signature)
(FI. MI. LAST Name of CO)

VOLUME 3: APPENDIX D

GCPC APPROVING OFFICIAL APPOINTMENT LETTER FORMAT

All changes are denoted by **blue font** unless a full revision has been conducted.

Hyperlinks are denoted by ***bold, italic, blue and underlined font***.

Base date of this Marine Corps Order (MCO) Volume (right header) will not change unless a full revision has been conducted. Upon full revision of this Volume, all changes denoted by blue font will reset to black font.

PAGE PARAGRAPH	EXPLANATION OF SUBSTANTIVE CHANGES	PURPOSE	DATE OF CHANGE

APPENDIX D

GCPC APPROVING OFFICIAL APPOINTMENT LETTER FORMAT

Below is an example format of the GCPC Approving Official (AO) appointment letter and COs have the discretion to modify accordingly; however, the content of this example includes the minimum requirements that will be used in all appointments. This does not replace the prescribed local Agency Program Coordinator (APC) appointment letter; however, the prescribed local APC appointment letter can be used in lieu of this example letter if it meets the minimum requirements identified in the below example and it is signed by the CO. The Supply Officer / Accountable Property Officer (APO) Appointment letter (see Appendix A) or DD 577 shall not serve as a replacement to this appointment letter.

4400
(code)
(Date)

From: Commanding Officer
To: (Rank First Name MI. Last Name)

Subj: APPOINTMENT AS GOVERNMENT COMMERCIAL PURCHASE CARD (GCPC)
CARDHOLDER

Ref: (a) DoD 7000.14-R
(b) NAVSUP 4200.99
(c) DON EBUSOPSOFFINST 4200.1A
(d) MCO 4400.201 Volume 3
(e) Installation GCPC SOP
(f) NAVSUPINST 4200.85D, Enclosure (2)

Encl: (1) DD 577

1. Per the references, you are appointed as a GCPC Approving Official for *(add unit name)*, Department of Defense Activity Code (DoDAAC)/Unit Identification Code (UIC): *(add DoDAAC)/(add UIC)*. You are directed to comply with the references and other applicable directions in the performance of your duties and responsibilities.
2. Your assigned GCPC APC is: (enter the Rank First Name MI Last Name of the appointed GCPC Agency Program Coordinator).
3. As the GCPC AO, you will approve the allocation of funding for execution in the Standard Accounting Budgeting and Reporting System (SABRS) for Work Center Identification (WCI): *(enter applicable WCI)*, Budget Execution Activity (BEA): *(enter applicable BEA(s))*, Budget Execution Sub-Activity (BESA): *(enter applicable BESA(s))* via the Supply Resource Manager.
4. As indicated in the references, you will:

13 JUN 2016

- a. Review and approve all CH statements and reconcile when Cardholders (CH) fails to do so in a timely manner.
- b. Review all purchase documentation and verify that CH transactions are proper, legal, mission essential and correct in accordance with government rules and regulations.
- c. Sign and date the AO account statement.
- d. Notify the APC of any improper purchases and record all improper purchases in the approved Department of the Navy (DON) data mining tool.
- e. Track purchases paid for, but not received, and monitor related disputes until the transaction issue is resolved.
- f. Use the DON data mining tool to review transactions.
- g. Validate that the CH fulfills their responsibilities.
- h. Resolve any questionable purchases with the CH.
- i. Notify the APC immediately to close a CH account when the CH is transferred, terminated, or is in absent-without leave status.
- j. Notify the APC of planned AO reassignment or departure.
- k. Notify the A/OPC of lost/stolen cards.
- l. Recommend dollar limits and inclusion/exclusion of other merchant category codes to further reduce the risk of misuse to the APC for CHs under their purview.

(Signature)
(FI. MI. LAST Name of CO)

VOLUME 3: APPENDIX E

GCPC CARDHOLDER APPOINTMENT LETTER FORMAT

All changes are denoted by **blue font** unless a full revision has been conducted.

Hyperlinks are denoted by ***bold, italic, blue and underlined font***.

Base date of this Marine Corps Order (MCO) Volume (right header) will not change unless a full revision has been conducted. Upon full revision of this Volume, all changes denoted by blue font will reset to black font.

PAGE PARAGRAPH	EXPLANATION OF SUBSTANTIVE CHANGES	PURPOSE	DATE OF CHANGE

APPENDIX E

GCPC CARDHOLDER APPOINTMENT LETTER FORMAT

Below is an example format of the GCPC Cardholder (CH) appointment letter and COs have the discretion to modify accordingly; however, the content of this example includes the minimum requirements that will be used in all appointments. This does not replace the prescribed local APC appointment letter; however, the prescribed local APC appointment letter can be used in lieu of this example letter if it meets the minimum requirements identified in the below example and it is signed by the CO. The Supply Officer/ Accountable Property Officer (APO) Appointment letter (see Appendix A) or DD 577 shall not serve as a replacement to this appointment letter.

4400
(code)
(Date)

From: Commanding Officer
To: (Rank First Name MI. Last Name)

Subj: APPOINTMENT AS GOVERNMENT COMMERCIAL PURCHASE CARD (GCPC)
CARDHOLDER

Ref: (a) DoD 7000.14-R
(b) NAVSUP 4200.99
(c) DON EBUSOPSOFFINST 4200.1A
(d) MCO 4400.201 Volume 3
(e) Installation GCPC SOP
(f) NAVSUPINST 4200.85D, Enclosure (2)

Encl: (1) DD 577

1. Per the references, you are appointed as a GCPC Cardholder for *(add unit name)*, Department of Defense Activity Code (DoDAAC)/Unit Identification Code (UIC): *(add DoDAAC)/(add UIC)*. You are directed to comply with the references and other applicable directions in the performance of your duties and responsibilities.

2. Your assigned GCPC Approving Official (AO) is: (enter the Rank First Name MI Last Name of the appointed GCPC Approving Official).

3. Funding will be allocated to you via the Supply Resource Manager for execution, upon approval from the GCPC AO, in the Standard Accounting Budgeting and Reporting System (SABRS) for Work Center Identification (WCI): *(enter applicable WCI)*, Budget Execution Activity (BEA): *(enter applicable BEA(s))*, Budget Execution Sub-Activity (BESA): *(enter applicable BESA(s))*.

4. As indicated in the references, you will:

- a. Properly use the card to purchase authorized goods and services only.

- b. Use the card ethically.
- c. Ensure availability of funds before purchase.
- d. Observe authorized dollar limits on purchases to include any additional charges; i.e., shipping, currency exchange fees.
- e. Purchase supplies and services from required sources such as AbilityOne, when available, within the required time frame.
- f. Instruct the vendor not to charge the GCPC until after the supplies are shipped.
- g. Request that purchases be exempt from state sales tax.
- h. Notify the property accountability official of pilferable, sensitive, or high valued property obtained with the GCPC, in accordance with their activity's established property accountability policy.
- i. Maintain a log for all purchases.
- j. Obtain receipts for all purchases.
- k. Reconcile all bank statement transactions with a purchase log.
- l. Contact the merchant to resolve questionable transactions prior to contacting the bank or disputing the transaction.
- m. Maintain vigilance of identity theft schemes attempting to gain access to financial information.
- n. Secure GCPC information by keeping the card in a safe, secure location, encrypting full account information when transmitting electronically, and using short account numbers if transmission is not encrypted.
- o. Immediately report if your card is lost or stolen, first to the card-issuing bank, then to your A/OPC.
- p. Destroy lost or stolen cards if recovered.
- q. Return your card upon leaving the GCPC role, the unit, or retiring.
- r. Do NOT use your purchase card to purchase the following prohibited items. See reference (f) for full explanation and background information on prohibited purchases.
 - 1. Items or services not for government use or of a personal nature such as fines, court costs, bail and bond payments, alimony, child support, dating and escort services, casino gaming chips, off-track betting, travel or travel-related expenses, tax payments, payment of salaries and wages, gifts and mementoes.

13 JUN 2016

2. Monetary items or services such as wire transfers, savings bonds, gift card, money orders, travelers' checks foreign currency.
3. Buildings and/or land or lease of long-term rental. Long term is defined as one month.
4. Commercial vehicles. Sales, rental and lease of vehicles to include boats, vessels, helicopters are prohibited.
5. Repair of GSA-leased vehicles.
6. Transportation of household goods, freight and logistics shipments.
7. Aircraft fuel and oil.
8. Purchases from contractors or contractor agents who are military personnel or civilian employees of the Federal Government.
 - s. Do NOT allow others to use your GCPC.
 - t. Do NOT split purchases in order to stay below your authorized spend limit.
 - u. Do NOT sign any vendor written terms and conditions that would financially bind the government without proper authority, when making a purchase.
 - v. Discuss with your AO or APC if uncertain as to whether a purchase is appropriate.
 - w. Ensure proper preparation of requisitioning source documents.
 - x. Ensure timely and accurate processing of monthly billing statements and updates of the cardholder's automated system, if applicable.
 - y. Maintain appropriate financial records and source documents.
 - z. Reconcile source documents with the Supply Resource Manager and GCPC AO to ensure the accurate recording of accounting transactions in the appropriate accounting system.
 - aa. Frequently review available information from contractor and other automated purchase card support systems in order to promptly identify improper use.
 - ab. Take timely and proper action when unauthorized charges occur.

(Signature)
(FI. MI. LAST Name of CO)

VOLUME 3: APPENDIX F

CERTIFYING OFFICER APPOINTMENT LETTER FORMAT

All changes are denoted by **blue font** unless a full revision has been conducted.

Hyperlinks are denoted by ***bold, italic, blue and underlined font***.

Base date of this Marine Corps Order (MCO) Volume (right header) will not change unless a full revision has been conducted. Upon full revision of this Volume, all changes denoted by blue font will reset to black font.

PAGE PARAGRAPH	EXPLANATION OF SUBSTANTIVE CHANGES	PURPOSE	DATE OF CHANGE

APPENDIX F

CERTIFYING OFFICER APPOINTMENT LETTER FORMAT

Below is an example format of the Certifying Officer appointment letter and COs have the discretion to modify accordingly; however, the content of the example is the minimum requirements that will be used in all appointments.

4400
(code)
(Date)

From: Commanding Officer
To: (Rank First Name MI. Last Name)

Subj: APPOINTMENT AS CERTIFYING OFFICER

Ref: (a) DoD 7000.14-R
(b) MCO 4400.201 Volume 3

Encl: (1) DD 577

1. Per the references, you are appointed as a Certifying Officer for *(add unit name)*, Department of Defense Activity Code (DoDAAC)/Unit Identification Code (UIC): *(add DoDAAC)/(add UIC)*. You are directed to comply with the references and other applicable directions in the performance of your duties and responsibilities.

2. You will promptly certify vouchers for payment in the Standard Accounting Budgeting and Reporting System (SABRS) under WCI: *(enter applicable WCI)*, BEA: *(enter applicable BEA(s))*, BESA: *(enter applicable BESA(s))*. Your specific duties include:

a. Attest to the correctness of statements, facts, accounts, and amounts appearing on a voucher, and certifying the voucher as correct and proper for payment.

b. Provide oversight to Departmental Accountable Officials (DAOs) (i.e., Responsible Officers, Resource Manager/Fund Holders) to strengthen internal controls.

c. Ensure proper preparation of all source documents and availability of funds prior to certifying payment.

(Signature)
(FI. MI. LAST Name of CO)

VOLUME 3: APPENDIX G

COMMANDING OFFICER CERTIFICATE OF RELIEF FORMAT

All changes are denoted by **blue font** unless a full revision has been conducted.

Hyperlinks are denoted by ***bold, italic, blue and underlined font***.

Base date of this Marine Corps Order (MCO) Volume (right header) will not change unless a full revision has been conducted. Upon full revision of this Volume, all changes denoted by blue font will reset to black font.

PAGE PARAGRAPH	EXPLANATION OF SUBSTANTIVE CHANGES	PURPOSE	DATE OF CHANGE

APPENDIX G

COMMANDING OFFICER CERTIFICATE OF RELIEF FORMAT

Below is an example format of the outgoing CO Certificate of Relief letter. COs have the discretion to modify accordingly; however, the content of the example is provided as an outline to ensure the relieving CO is provided the minimum information required to assess the overall status of the account upon assumption of command.

4400
(code)
(Date)

From: (Rank First Name MI. Last Name of outgoing CO)

To: (Rank First Name MI. Last Name of relieving CO)

Subj: COMMANDING OFFICER CERTIFICATE OF RELIEF

Ref: (a) MCO 4400.201 Volume 3

Encl: (1) Wall-to-Wall Inventory
(2) CMR/CAR Account Listing
(3) BEA/BESA Authorizations and Status
(4) Supply Manning summary
(5) NAVMC 11867

1. Per the references, a comprehensive review of the *(add unit name)* supply account, *(add DoDAAC)/(add UIC)*, has been conducted and all relevant areas have been addressed in the following paragraphs.
2. Property Control. *(Provide a summary of property control to include the following topics: Table of Equipment, Wall to Wall Inventory, Mechanized Allowance Listing, Consolidated Memorandum Receipts, Garrison Property, pending actions (e.g., current/pending investigations/discrepancy letters), miscellaneous property control issues (e.g., TOECRs, UUNS, etc.), and/or additional inventory (e.g., demand supported inventory, etc.)).*
3. Fiscal. *(Provide an overview of the current fiscal posture to include funding allocation (WCI/BEA/BESA), status of funds, unique requisitioning procedures, significant open requisitions, and/or GCPC/fund holder assignments (NAVMC 11867).)*
4. Warehouse. *(Provide an overview of warehouse operations to include personal effects and/or significant warehouse concerns.)*
5. Personnel. *(Provide a summary of current supply manning.)*
6. Summary. *(Provide final thoughts on the status of the account.)*

(Signature)

(FI. MI. LAST Name of outgoing CO)

VOLUME 3: APPENDIX H

**SUPPLY OFFICER/ACCOUNTABLE PROPERTY OFFICER CERTIFICATE
OF RELIEF FORMAT**

All changes are denoted by **blue font** unless a full revision has been conducted.

Hyperlinks are denoted by ***bold, italic, blue and underlined font***.

Base date of this Marine Corps Order (MCO) Volume (right header) will not change unless a full revision has been conducted. Upon full revision of this Volume, all changes denoted by blue font will reset to black font.

PAGE PARAGRAPH	EXPLANATION OF SUBSTANTIVE CHANGES	PURPOSE	DATE OF CHANGE

APPENDIX H

**SUPPLY OFFICER/ACCOUNTABLE PROPERTY OFFICER CERTIFICATE OF RELIEF
FORMAT**

Below is an example format of the outgoing Supply Officer/Accountable Property Officer (APO) Certificate or Relief letter. Supply Officers/APOs have the discretion to modify accordingly; however, the content of the example is provided as an outline to ensure the relieving Supply Officer/APO is provided the minimum information required to assess the overall status of the account upon assumption of command. At that time, the relieving Supply Officer/APO will conduct the necessary supply inspections to determine the condition of materiel, records, and operating procedures and document the results to the CO as an endorsement to the outgoing Supply Officer's/APOs Certificate of Relief.

4400
(code)
(Date)

From: (Rank First Name MI. Last Name of outgoing Supply Officer/Accountable Property Officer)

To: (Rank First Name MI. Last Name of relieving Supply Officer/Accountable Property Officer)

Subj: SUPPLY OFFICER/ACCOUNTABLE PROPERTY OFFICER CERTIFICATE OF RELIEF

Ref: (a) MCO 4400.201 Volume 3

Encl: (1) NAVMC 11867
(2) Wall-to-Wall Inventory
(3) CMR/CAR Account Listing
(4) BEA/BESA Authorizations and Status
(5) Supply Manning summary

1. Per the references, a comprehensive review of the (*add unit name*) supply account, (*add DoDAAC*)/(*add UIC*), has been conducted and all relevant areas have been addressed in the following paragraphs.

2. Property Control. (*Provide a summary of property control to include the following topics: Table of Equipment, Wall to Wall Inventory, Mechanized Allowance Listing, Consolidated Memorandum Receipts, Garrison Property, pending actions (e.g., current/pending investigations/discrepancy letters), miscellaneous property control issues (e.g., TOECRs, UUNS, etc.), and/or additional inventory (e.g., demand supported inventory, etc.)*).

3. Fiscal. (*Provide an overview of the current fiscal posture to include funding allocation (WCI/BEA/BESA), status of funds, unique requisitioning procedures, significant open requisitions, and/or GCPC/fund holder assignments (NAVMC 11867)*).

13 JUN 2016

4. Warehouse. *(Provide an overview of warehouse operations to include personal effects and/or significant warehouse concerns.)*
5. Personnel. *(Provide a summary of current supply manning.)*
6. Summary. *(Provide final thoughts on the status of the account)*

(Signature)
(FI. MI. LAST Name of outgoing Supply
Officer)

VOLUME 3: APPENDIX I

CLASSES AND SUBCLASSES OF SUPPLY

All changes are denoted by **blue font** unless a full revision has been conducted.

Hyperlinks are denoted by ***bold, italic, blue and underlined font***.

Base date of this Marine Corps Order (MCO) Volume (right header) will not change unless a full revision has been conducted. Upon full revision of this Volume, all changes denoted by blue font will reset to black font.

PAGE PARAGRAPH	EXPLANATION OF SUBSTANTIVE CHANGES	PURPOSE	DATE OF CHANGE

APPENDIX I

CLASSES AND SUBCLASSES OF SUPPLY

Class	Description	Subclass	Title	Description
I	Subsistence.	A	Air (Aviation, Aircraft, Airdrop Equipment)	Class I—Food packet, inflight, individual.
		C	Operational Rations	Includes the standard B ration, which is used for group feeding in areas where kitchen facilities, except refrigeration, are available and ration supplement sundries packs are issued in conjunction with the standard B ration until normal post exchange facilities are provided.
		R	Refrigerated Subsistence	Consists of two categories of refrigeration--that which is required to be maintained at 0°F to keep frozen meals and foods for extended periods and that which is to be maintained at approximately 40°F to keep perishables in A rations--such as fruits, vegetables, and eggs--for shorter periods.
		S	Nonrefrigerated Subsistence	Includes items in standard B rations and nonperishable items in A rations.
		W	Ground	Class I - Water—When delivered as a supply item.
		X	In Class	Indicates no subclass assigned.
II	Clothing, individual equipment, tentage, organizational tools sets and tool kits, hand tools, maps, and administrative and housekeeping supplies and equipment.	A	Air (Aviation, Aircraft, Airdrop Equipment)	Class II—Items of supply and equipment in support of aviation/aircraft.
		B	Troop Support Materiel	Consists of items such as water purification sets, shower, bath, laundry, drycleaning, and bakery equipment; sets, kits, and outfits (includes tool and equipment sets and shop/equipment sets for performing organization, DS, GS, and depot-level maintenance operations); sensors and interior intrusion devices; topographic equipment and related topographic products as outlined in AR 115-11.
		E	General Supply Items	Includes administrative expendable supplies such as typewriter ribbons, paper, cleaning materials, and other supplies normally referred to as office supplies; also includes publications distributed AG channels.
		F	Clothing and Textiles	Includes individual and organizational items of clothing and equipment authorized in allowance tables and tentage/tarpaulins authorized in TOE or other media.
		H	Test, Measurement, and Diagnostic Equipment	Includes items of equipment used to determine the operating efficiency of, or diagnose incipient problems in, systems, components, assemblies, and subassemblies of materiel used by the Army.
		W	Ground	Classes II, VII, and IX—Consist of construction/ road-building and materials-handling equipment.
		X	In Class	Indicates no subclass assigned.
		Z	Chemical	Class II— Battledress overgarments, M256 chemical detector kits.
III	POL: petroleum fuels; lubricants; hydraulic and insulating oils; preservatives; liquid and compressed gasses; bulk chemical products; coolants; deicing and antifreeze compounds, together with components and additives of such products; and coal.	A	Air (Aviation, Aircraft, Airdrop Equipment)	Class III-Petroleum and chemical products used in support of aircraft.
		W	Ground	Class III—Includes petroleum/chemical products and solid fuels used in support of ground and marine equipment.
		X	In Class	Indicates no subclass assigned.
		1	Air, Bulk Fuels	Includes jet fuels and aviation gasolines, normally transported by pipeline, rail tank car, tank truck, barge, coastal or oceangoing tankers, and stored in a tank or container having a fill capacity greater than 500 gallons.
		2	Air, Packaged Bulk Fuels	Includes fuels in subclass 1 which, because of operational necessity, are generally packaged and supplied in containers of 5- to 55-gallon capacity, except fuels in military collapsible containers of 500 gallons or less which will also be considered as packaged fuels.
		3	Air, Packaged Petroleum Products	Includes aircraft-unique petroleum and chemical products consisting generally of lubricating oils, greases, and specialty items normally packaged by the manufacturer and procured, stored, transported, and issued in containers or packages of 55-gallon capacity or less.
		4	Ground, Bulk Fuels	Includes motor gasoline, diesel, kerosene, and heating oils normally transported by pipeline, rail tank car, tank truck, barge, coastal or oceangoing tankers, and stored in a tank or container having a fill capacity greater than 500 gallons.
		5	Ground, Packaged Bulk Fuels	Includes ground bulk fuels which, because of operational necessity, are generally packaged and supplied in containers of 5- to 55-gallon capacity, except fuels in military collapsible containers of 500 gallons or less which will also be considered as packaged fuels.
		6	Ground, Packaged Petroleum	Includes petroleum and chemical products, generally lubricating oils, greases, and specialty items normally packaged by the manufacturer and procured, stored, transported, and issued in containers of 55-gallon capacity or less.
7	Ground, Solid Fuels	Includes coal, coke heating tables, or bars.		

MANAGEMENT OF PROPERTY IN THE POSSESSION OF THE MARINE CORPS
Volume 3, Appendix I

MCO 4400.201-V-3

13 JUN 2016

Class	Description	Subclass	Title	Description
IV	Construction materials, including installed equipment and all fortification/barrier materials.	T	Industrial Supplies	Common supplies and repair parts such as shop stocks, hardware, and fabrication-type items generally having multiple uses. The Defense Industrial Supply Center generally manages such items.
		X	In Class	Indicates no subclass assigned.
V	Ammunition of all types, including chemical and special weapons, bombs, explosives, mines, fuses, detonators, pyrotechnics, missiles, rockets, propellants, and other associated items.	A	Air (Aviation, Aircraft, Airdrop Equipment)	Class V—Munitions delivered by aircraft or aircraft weapons systems.
		L	Missiles	Classes H, VII, and IX include guided missile and rocket systems such as Patriot, MLRS, and Avenger. Class V includes guided missile ammunition items.
		N	Special Weapons	Class V—Includes nuclear and thermonuclear munitions.
		W	Ground	Class V - Conventional munitions—Consists of chemical smoke and illuminating, incendiary, riot control, and improved conventional munitions.
		X	In Class	Indicates no subclass assigned.
VI	Personal demand items (nonmilitary sales items).	X	In Class	Indicates no subclass assigned.
VII	Major end items: a final combination of end products that are ready for their intended use, for example, tanks, launchers, mobile machine shops, and vehicles.	A	Air (Aviation, Aircraft, Airdrop Equipment)	Class VII-Major end items of aviation equipment.
		B	Troop Support Materiel	Consists of items such as water purification sets, shower, bath, laundry, drycleaning, and bakery equipment; sets, kits, and outfits (includes tool and equipment sets and shop/equipment sets for performing organization, DS, GS, and depot-level maintenance operations); sensors and interior intrusion devices; topographic equipment and related topographic products as outlined in AR 115-11.
		D	Commercial Vehicles	Includes wheeled vehicles authorized for use in administrative or tactical operations.
		G	Communications-Electronics	Includes signal items such as radio, telephone, satellite, avionics, marine communications and navigational equipment; tactical and nontactical ADPE; radar; photographic, audiovisual, and television equipment; and electronic sensors.
		H	Test, Measurement, and Diagnostic Equipment	Includes items of equipment used to determine the operating efficiency of, or diagnose incipient problems in, systems, components, assemblies, and subassemblies of materiel used by the Army.
		K	Tactical Vehicles	Includes truck tractors, trailers, semitrailers, and personnel carriers.
		L	Missiles	Classes H, VII, and IX include guided missile and rocket systems such as Patriot, MLRS, and Avenger. Class V includes guided missile ammunition items.
		M	Weapons	Includes small arms, artillery, fire control systems, rocket launchers, machine guns, air defense weapons, and aircraft weapon subsystems.
		N	Special Weapons	Class VII-Includes weapon systems that deliver nuclear munitions.
		O	Combat Vehicles	Includes main battle tanks, recovery vehicles, self-propelled artillery, armored cars, and tracked and half-tracked vehicles.
		P	US Army Intelligence and Security Command Materiel	Includes that materiel for which the US Army Intelligence and Security Command has responsibility. Normally authorized in classified authorization tables. Although USAINSCOM items are electronic, they are identified separately because they do not follow the same supply and maintenance channels as subclass G.
		Q	Marine Equipment	Includes marine items of supply and equipment such as amphibious vehicles, landing craft, barges, tugs, floating cranes, and dredges.
		U	COMSEC Materiel	This subclass is identified separately from subclass G because of specialized supply and maintenance performed through a dedicated COMSEC logistics system.
		W	Ground	Classes II, VII, and IX—Consist of construction/ road-building and materials-handling equipment.
		X	In Class	Indicates no subclass assigned.
Y	Railway Equipment	Includes rail items of supply and equipment such as locomotives, railcars, rails, rail joining, and shifting equipment.		
Z	Chemical	Class II— Battledress overgarments, M256 chemical detector kits.		

MANAGEMENT OF PROPERTY IN THE POSSESSION OF THE MARINE CORPS
Volume 3, Appendix I

MCO 4400.201-V-3

13 JUN 2016

Class	Description	Subclass	Title	Description
VIII	Medical materiel, including medical-peculiar repair parts.	A	Medical Materiel	
		B	Blood / Fluids	
IX	Repair parts (less medical-peculiar repair parts): all repair parts and components, to include kits, assemblies, and subassemblies--reparable and nonreparable-required for maintenance support of all equipment.	A	Air (Aviation, Aircraft, Airdrop Equipment)	Class IX--Aircraft repair parts.
		L	Missiles	Classes H, VII, and IX include guided missile and rocket systems such as Patriot, MLRS, and Avenger. Class V includes guided missile ammunition items.
		N	Special Weapons	Class IX--Includes repair parts for Class VII-N.
		T	Industrial Supplies	Common supplies and repair parts such as shop stocks, hardware, and fabrication-type items general having multiple uses. The Defense Industrial Supply Center generally manages such items.
		W	Ground	Classes II, VII, and IX--Consist of construction/ road-building and materials-handling equipment.
		X	In Class	Indicates no subclass assigned.
		Z	Chemical	Class II-- Battledress overgarments, M256 chemical detector kits.
X	Materiel to support nonmilitary programs, such as agricultural economic development, not included in Classes I through IX.	X	In Class	Indicates no subclass assigned.

VOLUME 3: APPENDIX J

TABLE OF AUTHORIZED MATERIEL CONTROL NUMBERS

All changes are denoted by **blue font** unless a full revision has been conducted.

Hyperlinks are denoted by ***bold, italic, blue and underlined font***.

Base date of this Marine Corps Order (MCO) Volume (right header) will not change unless a full revision has been conducted. Upon full revision of this Volume, all changes denoted by blue font will reset to black font.

PAGE PARAGRAPH	EXPLANATION OF SUBSTANTIVE CHANGES	PURPOSE	DATE OF CHANGE

APPENDIX J

TABLE OF AUTHORIZED MATERIEL CONTROL NUMBERS

Commodity	Type 1	Type 2	Type 3	Tactical Non-Standard Equipment (NS-E) *	Special Item Equipment (SIE)
Communications-Electronics	A0001-A9999	H0001-H9999	T0001-T9999	A0001-A9999	Q0001-Q9999
				H0001-H9999	
				T0001-T9999	
Engineer	B0001-B9999	J0001-J9999	U0001-U9999	B0001-B9999	
				J0001-J9999	
				U0001-U9999	
General Supply	C0001-C9999	K0001-K9999	V0001-V9999	C0001-C9999	
				K0001-K9999	
				V0001-V9999	
Motor Transport	D0001-D9999	M0001-M9999	W0001-W9999	D0001-D9999	
				M0001-M9999	
				W0001-W9999	
Ordnance	E0001-E9999	N0001-N9999	X0001-X9999	E0001-E9999	
				N0001-N9999	
				X0001-X9999	
For HQMC Use	TAMCNs starting with F, R, Y and Z				
Not Used	TAMCNs starting with I, L, and O				
Garrison Mobile Equipment**	G0001-G9999				
Petroleum	P0001-P9999				
Subsistence	S0001-S9999				

* NS-E can be assigned any TAMCN commodity designator, but will always have a MCSN instead of an NSN.

** Refer to reference (p) for further information.

VOLUME 3: APPENDIX K

REQUEST FOR HERITAGE ASSET DETERMINATION FORMAT

All changes are denoted by **blue font** unless a full revision has been conducted.

Hyperlinks are denoted by ***bold, italic, blue and underlined font***.

Base date of this Marine Corps Order (MCO) Volume (right header) will not change unless a full revision has been conducted. Upon full revision of this Volume, all changes denoted by blue font will reset to black font.

PAGE PARAGRAPH	EXPLANATION OF SUBSTANTIVE CHANGES	PURPOSE	DATE OF CHANGE

13 JUN 2016

APPENDIX K

REQUEST FOR HERITAGE ASSET DETERMINATION FORMAT

Requests to identify an item as a heritage asset will be submitted using the below format.

5750

Office Code

Date

From: Commanding Officer

To: Registrar, National Museum of the Marine Corps, 2014 Anderson Ave.,
Quantico, VA 22134-5002

Subj: REQUEST FOR HERITAGE ASSET DETERMINATION

Ref: (a) MCO 4400.201 Volume 3

(b) MCO 5750.1_

(c) MCO P10520.3_ (if applicable)

Encl (1) Digital Image(s) of potential Heritage Asset being reported (*include images of identify features such as serial number or part number, if applicable*)

(2) Copy of Limited Demilitarized Certificate (*if applicable*)

1. In accordance with the references, this request is submitted to identify an asset as a potential heritage asset.

2. The following asset description is provided with digital images provided as enclosure (1):

Nomenclature:

Part/Identification Number: (*if applicable*)

National/Marine Corps Stock Number: (*input NA if not assigned*)

Country of Origin:

Unit Price: (*if applicable*)

Unit of Issue: (*if applicable*)

Quantity:

Serially Controlled (Y/N) (*indicate "Yes" or "No"*)

Serial Number(s): (*input NA if not assigned*)

Estimated Annual Cost of Maintenance:

3. The significance of this asset is (*describe significance of object to the unit, date obtained, where obtained, background/provenance of asset, why it contributes to unit's traditions and/or esprit de corps and more readily allows the unit to exploit historical experiences*).

4. The physical condition and current location of this asset is (*describe condition as well as physical location of the asset(s)*).

13 JUN 2016

5. This command understands that approval of this request does not constitute authorization to maintain physical possession of the asset.

6. The point of contact for this matter is (include rank, full name, telephone number, and e-mail).

(Signature)

(FI. MI. LAST Name of CO)

VOLUME 3: APPENDIX L

**REQUEST FOR CONDITIONAL LOAN OR DISPLAY EQUIPMENT RETENTION
FORMAT**

All changes are denoted by **blue font** unless a full revision has been conducted.

Hyperlinks are denoted by ***bold, italic, blue and underlined font***.

Base date of this Marine Corps Order (MCO) Volume (right header) will not change unless a full revision has been conducted. Upon full revision of this Volume, all changes denoted by blue font will reset to black font.

PAGE PARAGRAPH	EXPLANATION OF SUBSTANTIVE CHANGES	PURPOSE	DATE OF CHANGE

APPENDIX L

REQUEST FOR CONDITIONAL LOAN OR DISPLAY EQUIPMENT RETENTION

FORMAT

Requests for conditional loan of heritage assets or retention of display equipment will be submitted using the below format.

5750

Office Code

Date

From: Commanding Officer

To: Commanding General, Marine Corps Installations Command

Via: *(insert appropriate chain of command as described in paragraph 10 of Chapter 6)*

Subj: REQUEST CONDITIONAL LOAN RETENTION or REQUEST DISPLAY EQUIPMENT RETENTION *(choose appropriate request based on heritage asset determination)*

Ref: (a) MCO 4400.201 Volume 3

(b) MCO 5750.1_

(c) MCBul 4410

(d) MCO P10520.3_ *(if applicable)*

Encl: (1) NMMC endorsement on REQUEST FOR HERITAGE ASSET DETERMINATION

(2) Digital Image(s) of asset(s) *(if not included in enclosure (1), include images of data plate and both sides (front and back) of the lower receiver for small arms, if applicable)*

(3) Copy of Limited Demilitarized Certificate *(if applicable)*

1. In accordance with the references, this command is requesting conditional loan retention of the below heritage asset. *(Change to "In accordance with the references, this command is requesting display retention of the below asset." if asset was not accepted by the NMMC as a heritage asset.)*

2. The following asset description is provided with digital images provided in enclosure (1): *(change "in enclosure (1)" to "in enclosure (2)" if not provided in enclosure (1))*

Nomenclature:

Part/Identification Number:

National/Marine Corps Stock Number: *(input NA if not assigned)*

Country of Origin:

Unit Price:

Unit of Issue:

Quantity:

Serially Controlled (Y/N) *(indicate "Yes" or "No")*

Serial Number(s): *(input NA if not assigned)*

Estimated Annual Cost of Maintenance:

13 JUN 2016

3. The significance of this asset is *(describe significance of object to the unit, date obtained, where obtained, background/provenance of asset, why it contributes to unit's traditions and/or esprit de corps and more readily allows the unit to exploit historical experiences)*.
4. The physical condition and current location of this asset is *(describe condition as well as location asset(s) will be physically displayed. Also describe security measures in place for safeguarding)*.
5. If authorized to maintain this asset as a heritage asset on conditional loan, stewardship responsibility will be established in the Department of the Navy Heritage Asset Management System (DONHAMS) by the NMMC. *(Use this paragraph if request is for conditional loan retention, use alternative paragraph 5 below if for display equipment retention)*
5. If authorized to maintain this asset as display equipment, accountability will be established using this command's base property sub-custody account *(insert DoDAAC/PPM sub-custody account number of unit requesting conditional loan)*, an account currently established under the *(insert installation name)* PPM, *(insert PPM DoDAAC)*. *(Use this paragraph if request is for display equipment retention, use alternative paragraph 5 above if for conditional loan retention)*
6. If approved for retention, this command understands its responsibility to maintain the asset in an acceptable condition. Any associated budget requirements for maintenance of the asset(s) will be coordinated with the installation commander identified above. *(If there are no expected maintenance requirements associated with the asset, add the last sentence "There are currently no expected maintenance support requirements for this asset.")*
7. The point of contact for this matter is (include rank, full name, telephone number, and e-mail).

(Signature)
(FI. MI. LAST Name of CO)

VOLUME 3: APPENDIX M

COMPARTMENT MARKINGS

All changes are denoted by **blue font** unless a full revision has been conducted.

Hyperlinks are denoted by ***bold, italic, blue and underlined font.***

Base date of this Marine Corps Order (MCO) Volume (right header) will not change unless a full revision has been conducted. Upon full revision of this Volume, all changes denoted by blue font will reset to black font.

PAGE PARAGRAPH	EXPLANATION OF SUBSTANTIVE CHANGES	PURPOSE	DATE OF CHANGE

APPENDIX M

COMPARTMENT MARKINGS

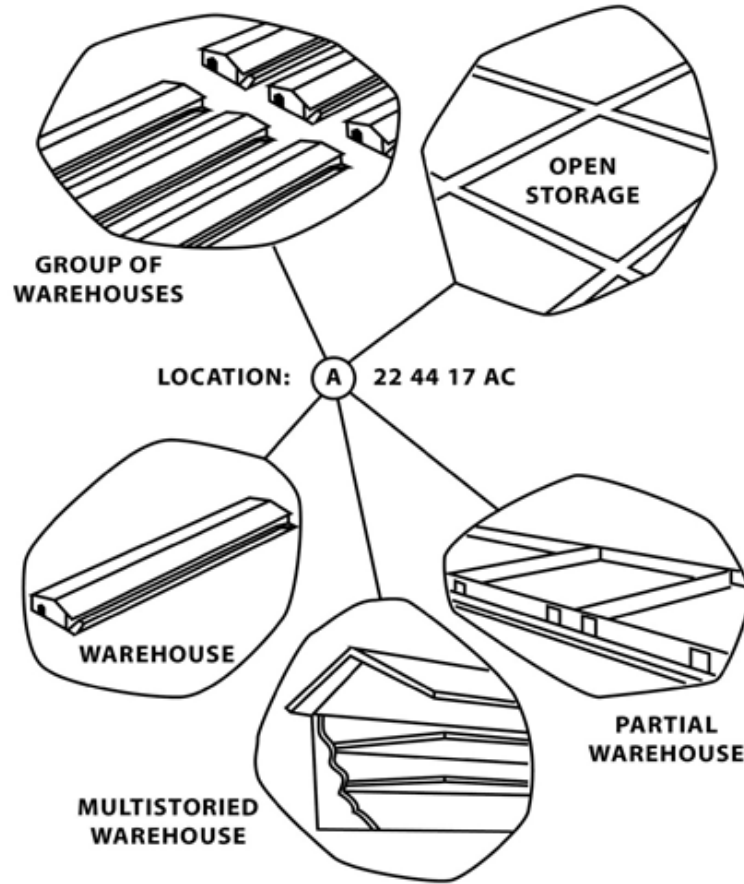

Figure M-1. Area Examples.

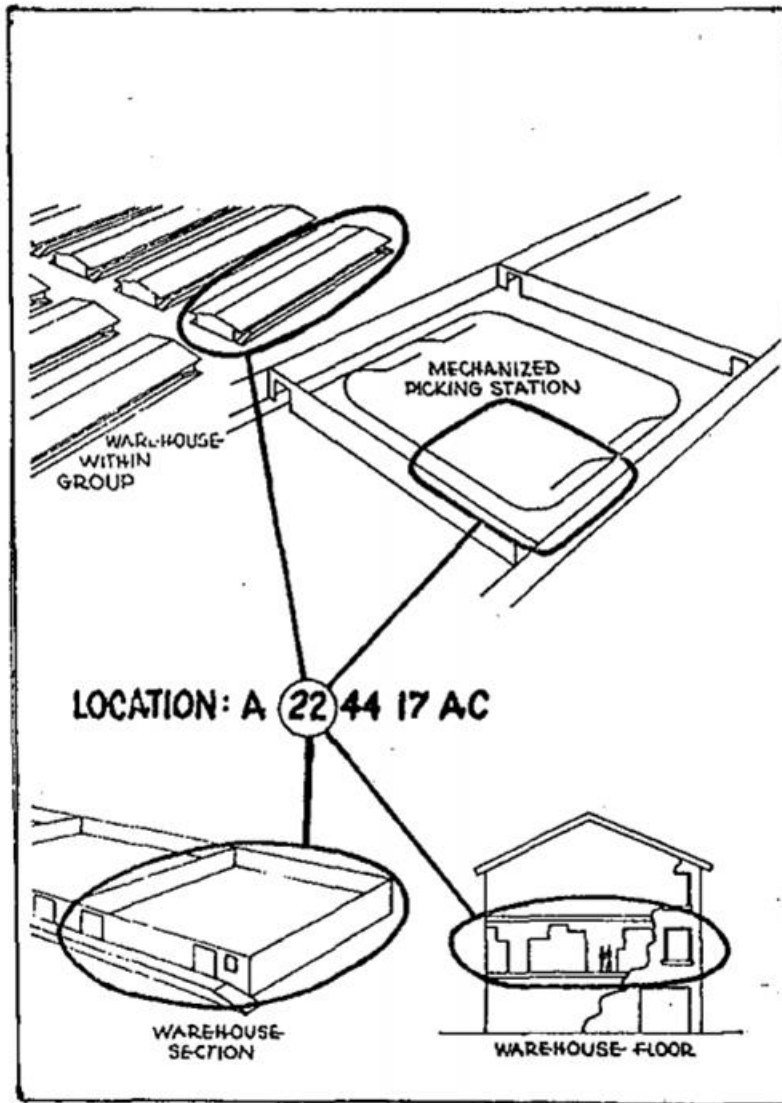

Figure M-2. Station Examples.

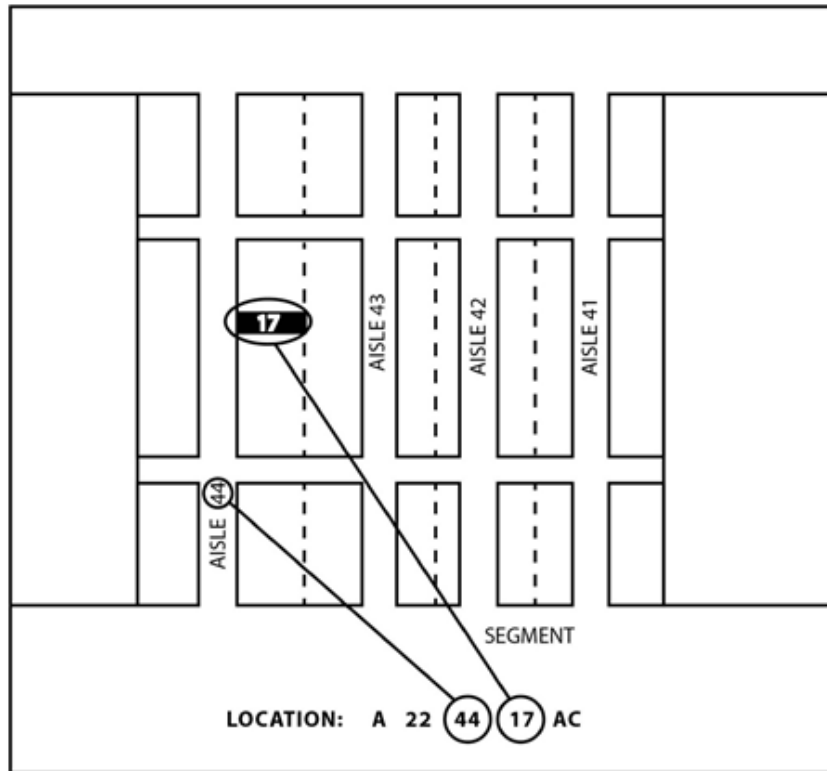

Figure M-3. Aisle and Segment Bulk Storage

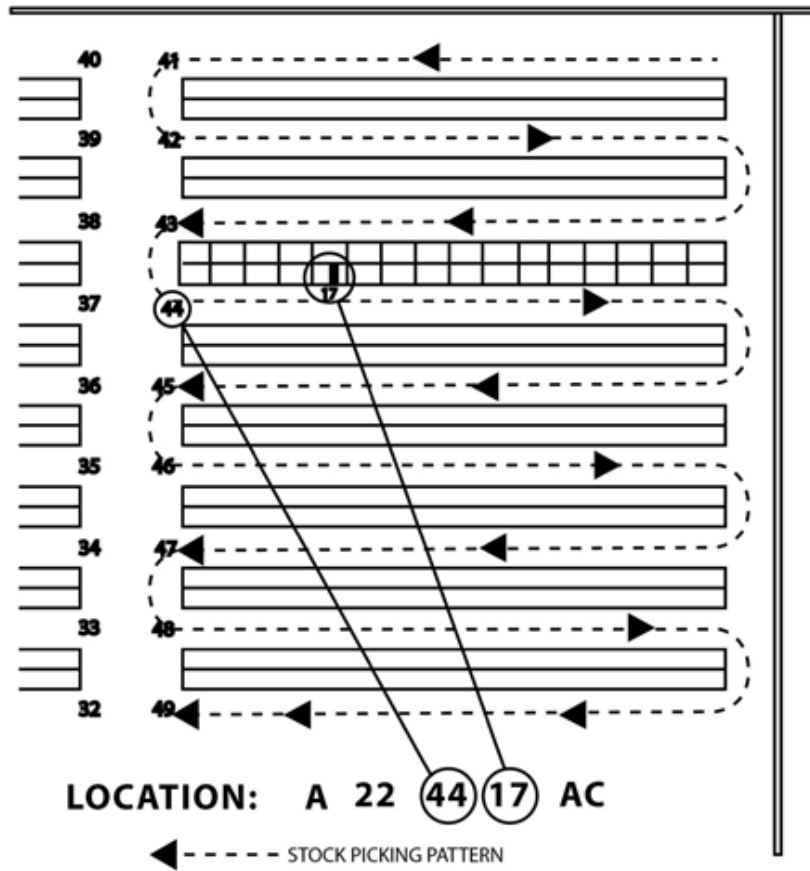

Figure M-4. Aisle and Segment Bin Storage

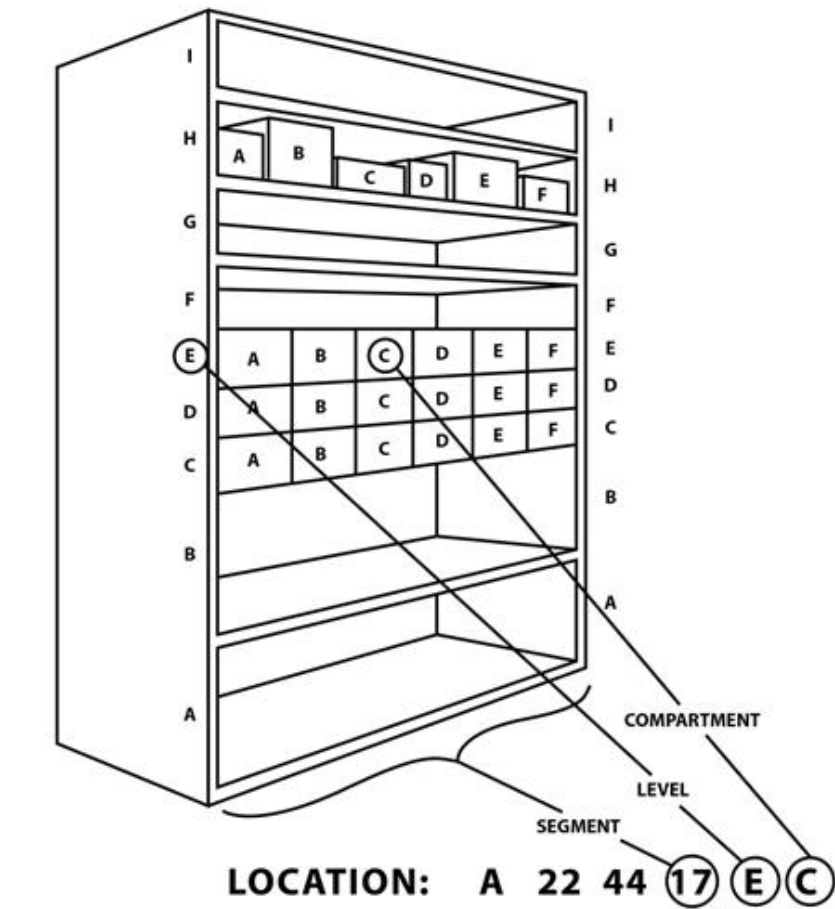

Figure M-5. Segment Level Compartment Bin Storage

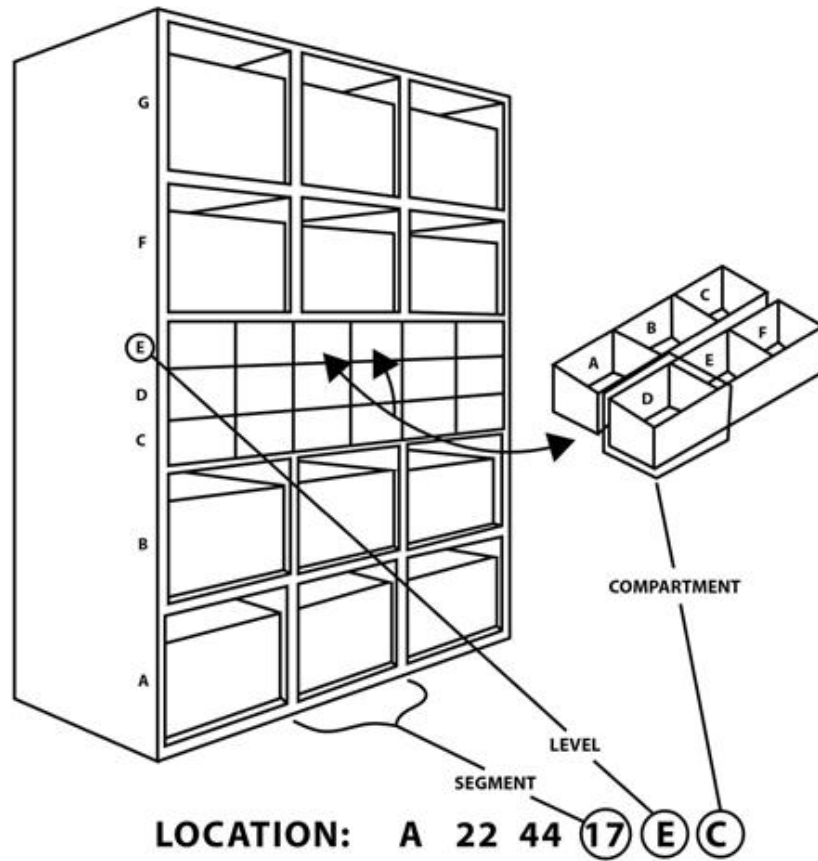

Figure M-6. Segment Level Compartment Divided Bin Storage

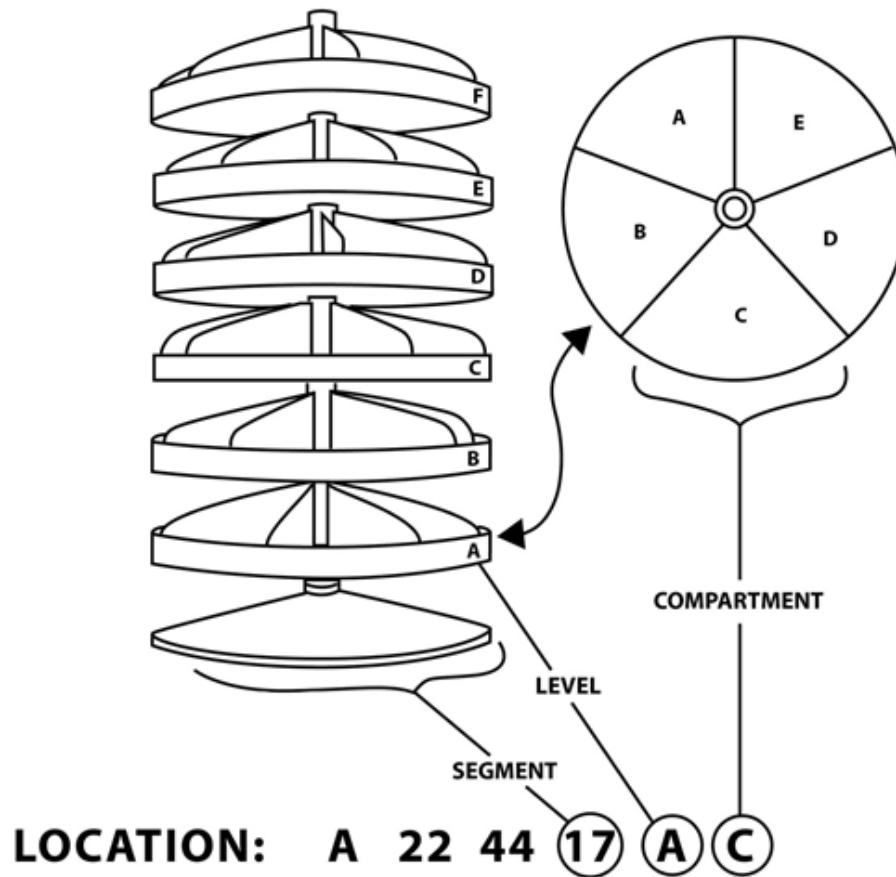

Figure M-7. Segment level Compartment Rotary Bin Storage

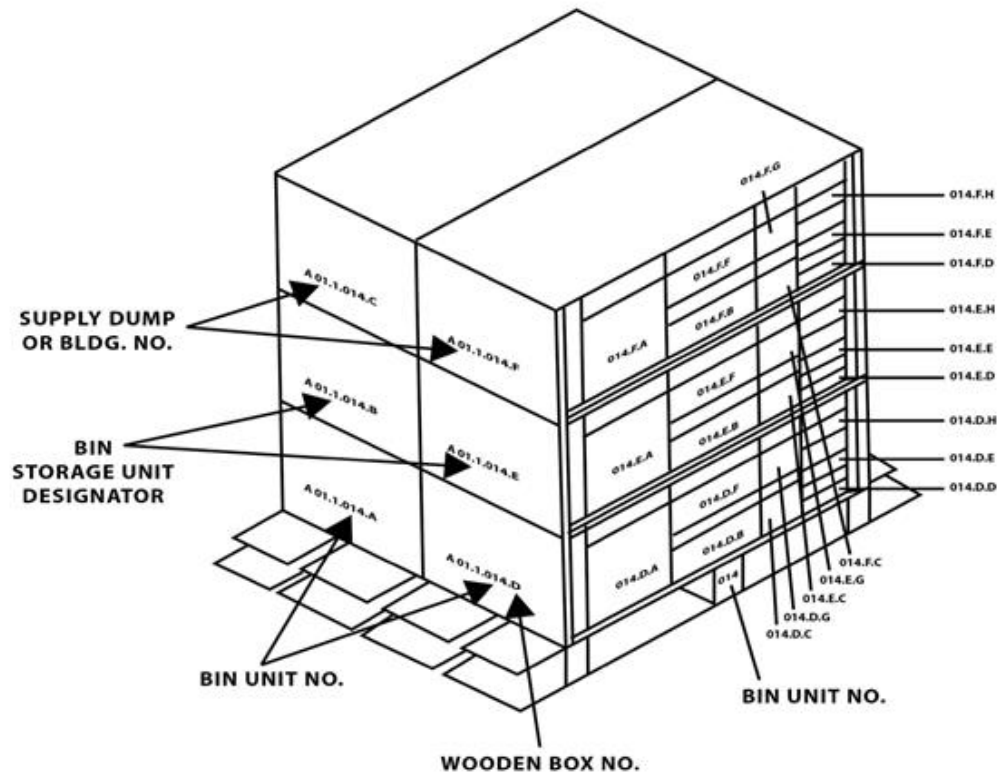

Figure M-8. Markings for Bin Storage Unit

VOLUME 3: APPENDIX N

STORAGE CONTAINERS

All changes are denoted by **blue font** unless a full revision has been conducted.

Hyperlinks are denoted by ***bold, italic, blue and underlined font***.

Base date of this Marine Corps Order (MCO) Volume (right header) will not change unless a full revision has been conducted. Upon full revision of this Volume, all changes denoted by blue font will reset to black font.

PAGE PARAGRAPH	EXPLANATION OF SUBSTANTIVE CHANGES	PURPOSE	DATE OF CHANGE

APPENDIX N

STORAGE CONTAINERS

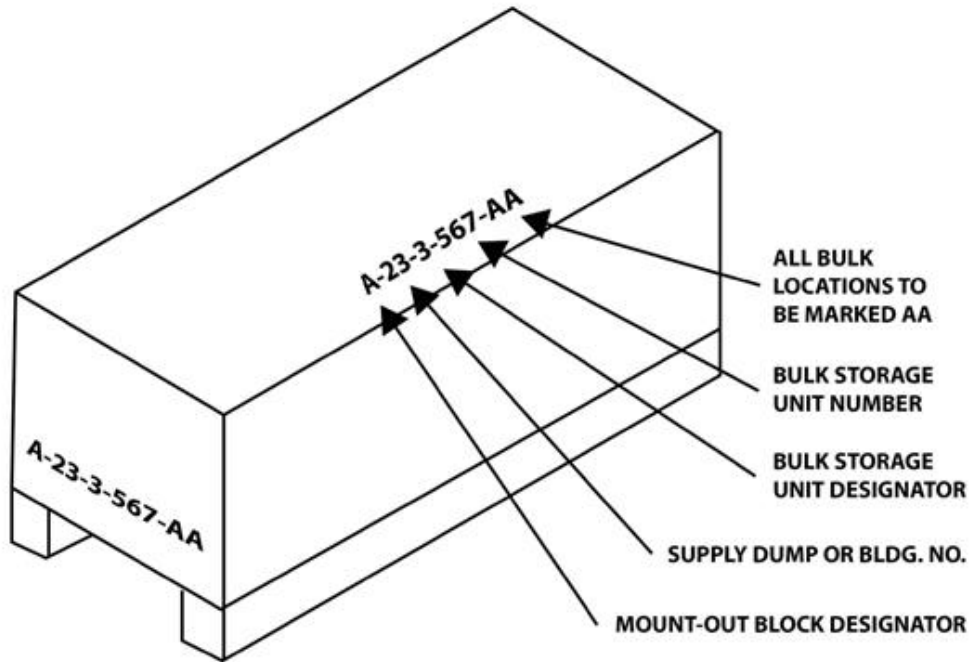

Figure N-1. Bulk Storage Units

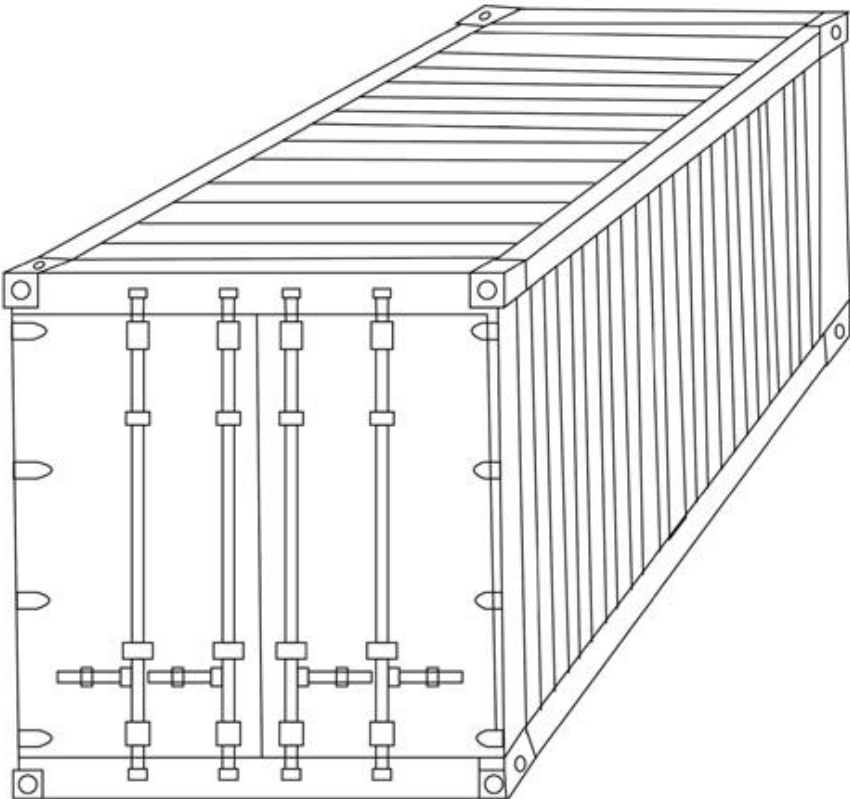

Figure N-2. Quadcons and ISO Containers Storage Unit

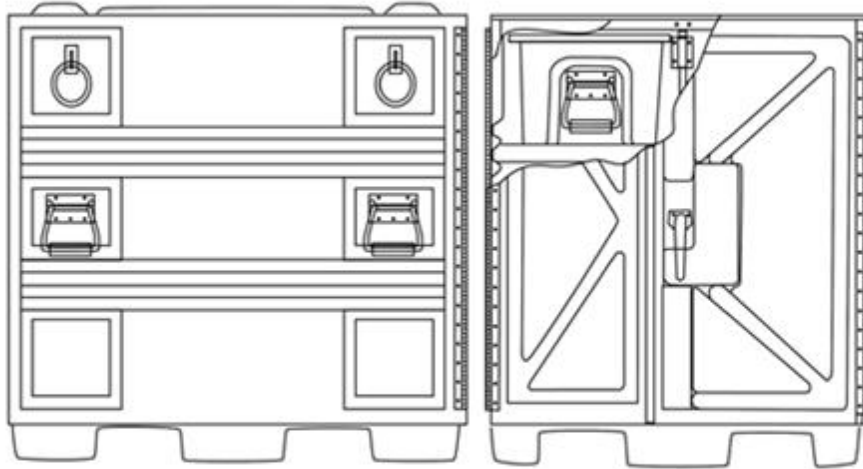

Figure N-3. Palcon Storage Unit

VOLUME 3: APPENDIX O

SHELF LIFE CODES

All changes are denoted by **blue font** unless a full revision has been conducted.

Hyperlinks are denoted by ***bold, italic, blue and underlined font***.

Base date of this Marine Corps Order (MCO) Volume (right header) will not change unless a full revision has been conducted. Upon full revision of this Volume, all changes denoted by blue font will reset to black font.

PAGE PARAGRAPH	EXPLANATION OF SUBSTANTIVE CHANGES	PURPOSE	DATE OF CHANGE

APPENDIX O

SHELF LIFE CODES

			Required Number of Months/Quarters Remaining Upon Receipt by the first Government activity
--	--	--	--

Shelf-Life Period	Type I	Type II	Months	Quarters
-------------------	--------	---------	--------	----------

Non-Deteriorative No Shelf-Life Applies	0 (zero)	0 (zero)	N/A	N/A
01 Month	A	N/A	25 days	N/A
02 Months	B	N/A	50 days	N/A
03 Months	C	1	75 days	N/A
04 Months	D	N/A	3	1
05 Months	E	N/A	4	1
06 Months	F	2	5	2
09 Months	G	3	8	3
12 Months (1.00-Year)	H	4	10	3
15 Months (1.25-Years)	J	N/A	13	4
18 Months (1.50-Years)	K	5	15	5
21 Months (1.75-Years)	L	N/A	18	6
24 Months (2.00-Years)	M	6	21	7
27 Months (2.25-Years)	N	N/A	23	8
30 Months (2.50-Years)	P	N/A	26	9
36 Months (3.00-Years)	Q	7	31	10
48 Months (4.00-Years)	R	8	41	14
60 Months (5.00-Years)	S	9	51	17
72 Months (6.00-Years)	I	N/A	61	20
84 Months (7.00-Years)	T	N/A	71	24
96 Months (8.00-Years)	U	N/A	82	27
Variable such as: 90, 132, 216, 228, etc. Months or any other number of months not specifically assigned.	V	N/A	77, 113, 184, 194, etc.	26, 38, 61, 65, etc.
120 Months (10-Years)	W	N/A	102	34
180 Months (15-Years)	Y	N/A	153	51
240 Months (20-Years)	Z	N/A	204	68
Shelf-Life Period Greater than 60 Months for Type II Extendible Items.	N/A	X	85 percent of number of months	85 percent of number of quarters

VOLUME 3: APPENDIX P

SUPPLY CONDITION CODES

All changes are denoted by **blue font** unless a full revision has been conducted.

Hyperlinks are denoted by ***bold, italic, blue and underlined font***.

Base date of this Marine Corps Order (MCO) Volume (right header) will not change unless a full revision has been conducted. Upon full revision of this Volume, all changes denoted by blue font will reset to black font.

PAGE PARAGRAPH	EXPLANATION OF SUBSTANTIVE CHANGES	PURPOSE	DATE OF CHANGE

APPENDIX P

SUPPLY CONDITION CODES

CODE	TITLE	DEFINITION
A	Serviceable (Issuable Without Qualification)	Shelf-life remaining is more than 6 months. *
B	Serviceable (Issuable With Qualification)	Shelf-life remaining is from 3-6 months. *
C	Serviceable (Customer Concurrence Required Prior To Issue)	Shelf life remaining is less than 3 months. *
E	Unserviceable (Limited Restoration)	Materiel which involves only limited expense or effort to restore to serviceable condition and which is accomplished in the S/A where the stock is located.
F	Unserviceable (Reparable)	Economically reparable materiel which requires repair, overhaul, or reconditioning includes reparable items which are radioactively contaminated.
H	Unserviceable (Condemned)	Type I shelf-life materiel that has passed the expiration date and Type II shelf-life materiel that has passed its inspection/ test date and cannot be extended.
J	Suspended (In Stock)	Type II shelf-life materiel that has reached the inspection or test date and is awaiting inspection test or restoration.
K	Suspended (Returns)	Materiel returned from customers or users and awaiting condition classification.
L	Suspended (Litigation)	Materiel held pending litigation or negotiation with contractors or common carriers.
R	Suspended (Reclaimed Items, Awaiting Condition Determination)	Assets turned in by reclamation activities which do not have the capability (e.g., skills, manpower, or test equipment) to determine the materiel condition. Actual Condition will be determined prior to induction into maintenance activity for repair/modification.

VOLUME 3: APPENDIX Q

**TEMPLATE FOR UPDATING TACTICAL NON-STANDARD EQUIPMENT
AND SPECIAL ITEM EQUIPMENT REQUIREMENTS**

All changes are denoted by **blue font** unless a full revision has been conducted.

Hyperlinks are denoted by ***bold, italic, blue and underlined font***.

Base date of this Marine Corps Order (MCO) Volume (right header) will not change unless a full revision has been conducted. Upon full revision of this Volume, all changes denoted by blue font will reset to black font.

PAGE PARAGRAPH	EXPLANATION OF SUBSTANTIVE CHANGES	PURPOSE	DATE OF CHANGE

