

**ARMY, MARINE CORPS, NAVY, AIR FORCE**



**MULTISERVICE TACTICS,  
TECHNIQUES, AND  
PROCEDURES FOR  
HEALTH SERVICE  
SUPPORT IN A  
CHEMICAL, BIOLOGICAL,  
RADIOLOGICAL, AND  
NUCLEAR ENVIRONMENT**

**FM 4-02.7  
MCRP 4-11.1F  
NTTP 4-02.7  
AFTTP 3-42.3**

**JULY 2009**

**DISTRIBUTION RESTRICTION:** Approved for public release; distribution is unlimited.

**MULTI-SERVICE TACTICS, TECHNIQUES, AND PROCEDURES**

## FOREWORD

This publication has been prepared under our direction for use by our respective commands and other commands as appropriate.

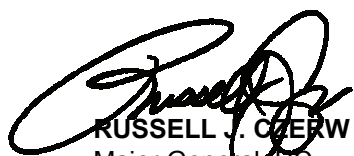

**RUSSELL J. CZERW**  
Major General, DC  
Commander, US Army Medical  
Department Center and School



**GEORGE J. FLYNN**  
Lieutenant General, US Marine Corps  
Deputy Commandant for Combat  
Development and Integration



**WENDI B. CARPENTER**  
Rear Admiral, US Navy  
Commander, Navy Warfare  
Development Command



**THOMAS J. LOFTUS**  
Major General, USAF, MC, CFS  
Assistant Surgeon General  
Health Care Operations  
Office of the Surgeon General

**This publication is available for downloading/ordering through the US Army at Army Knowledge Online (AKO) ([www.us.army.mil](http://www.us.army.mil)) and at the General Dennis J. Reimer Training and Doctrine Digital Library ([www.train.army.mil](http://www.train.army.mil)) Web sites; through the US Marine Corps Web site (<https://www.doctrine.usmc.mil>); through the US Navy at Navy Knowledge Online (<https://www.nko.navy.mil>) accessed via the Navy Warfare Library (located on the Reference Page) and the Navy Warfare Development Command SIPRNET Doctrine Discussion Group (DDG) ([www.nwdc.navy.smil.mil](http://www.nwdc.navy.smil.mil)); and through the US Air Force at the Air Force Publishing Web site ([www.e-publishing.af.mil](http://www.e-publishing.af.mil)).**

# PREFACE

## 1. Purpose

This publication establishes doctrinal multiservice tactics, techniques, and procedures (MTTPs) for health service support (HSS) units operating in a chemical, biological, radiological, and nuclear (CBRN) and toxic industrial material (TIM) environment. It is the intent of this document to inform the combatant commanders (CCDRs), joint force commanders (JFCs), joint force medical commanders and medical planners, and component commanders and their staffs on the tools available to provide the best quality of force health protection (FHP) and HSS in a CBRN environment to enhance mission success. This publication bridges the gaps between Service and joint HSS publications.

## 2. Scope

a. This publication provides information for use by the component commanders and their staffs, command surgeons, medical planners, and individuals responsible for FHP and HSS in a CBRN environment. Commanders have the direct responsibility for protecting their forces within a CBRN environment. On future battlefields, failure to properly plan and execute CBRN defensive operations may result in significant casualties, disruption of operations, and even mission degradation. Further, the commander's mission and execution plans must address the implications of HSS in a CBRN environment.

b. This publication contains MTTPs relative to HSS in the following specific areas:

- Chemical, biological, radiological, and nuclear aspect of HSS.
- Casualty prevention.
- Casualty care and management.
- Patient movement.
- Patient decontamination.
- Veterinary service support and food and water safety.
- Medical laboratory support.
- Combat and operational stress control (COSC).
- Health service logistic (HSL) support (HSLs).
- Homeland defense.
- Individual and collective protection systems.

c. For Service-specific information or detailed procedures refer to—

- Appendix A, Chemical, Biological, Radiological, and Nuclear Casualty Estimation.
- Appendix B, Health Service Support Chemical, Biological, Radiological, and Nuclear Annex to an Operation Plan/Operation Order.
- Appendix C, Service-Specific Tasks List.
- Appendix D, Service-Specific Chemical, Biological, Radiological, and Nuclear Defense Capabilities.

## 3. Applicability

a. The audience for this publication is the trained members of the Armed Forces Medical Services and other medically qualified personnel.

b. This publication implements North Atlantic Treaty Organization (NATO) International Standardization Agreement (STANAG) 2931, Orders for the Camouflage of the Red Cross

and Red Crescent on Land in Tactical Operations. It is also in consonance with the following NATO STANAGs and American, British, Canadian, and Australian Armies Program (ABCA) Quadripartite Standardization Agreements (QSTAGs):

TITLE	STANAG	QSTAG
Warning Signs for the Marking of Nuclear, Biological, and Chemical Contaminations	2002	501
Emergency Alarms of Hazard or Attack (NBC and Air Attack Only)	2047	
Emergency War Surgery	2068	
Interoperable Chemical Agent Detector Kits		608
Commander's Guide on Nuclear Radiation Exposure of Groups During War	2083	
Reporting Nuclear Detonations, Biological and Chemical Attacks, and Predicting and Warning of Associated Hazards and Hazard Areas (Operators Manual)—ATP-45(C)	2103	187
Friendly Nuclear Strike Warning (STRIKWARN)	2104	189
Nuclear, Biological, and Chemical Reconnaissance	2112	
Documentation Relative to Medical Evacuation, Treatment, and Causes of Death of Patients	2132	470
Allied Joint Medical Support Doctrine—AJP-4.10(A)	2228	
Basic Military Hospital (Clinical) Records	2348	
NATO Handbook on the Medical Aspects of NBC Defensive Operations (Biological)—AMedP-6(C) Volume II	2462	
Planning Guide for the Estimation of NBC Battle Casualties (Nuclear)—AMedP-8(A), Volume I	2475	
Medical Planning Guide of NBC Battle Casualties (Biological)—AMedP-8(B), Volume II	2476	
Planning Guide for the Estimation of NBC Battle Casualties (Chemical)—AMedP-8(A), Volume III	2477	
Medical Support Planning for Nuclear, Biological and Chemical Environments	2478	
Materials Handling in the Field	2827	
Concept of Operations of Medical Support in Chemical, Biological, Radiological, and Nuclear Environments—AMedP-7(D)	2873	
Principles of Medical Policy in the Management of a Mass Casualty Situation	2879	
Emergency Supply of Water in War	2885	

TITLE	STANAG	QSTAG
Orders for the Camouflage of the Red Cross and Red Crescent on Land in Tactical Operations	2931	
Guidelines for Air and Ground Personnel Using Fixed and Transportable Collective Protection Facilities on Land	2941	
Training of Medical Personnel for NBC Defence Operations	2954	

c. The use of trade names or trademarks in this publication is for illustrative purposes only. Their use does not constitute endorsement by the Department of Defense (DOD).

d. The proponent of this publication is the United States (US) Army Medical Department Center and School (USAMEDDC&S). Send comments and recommendations directly to **Commander, US Army Medical Department Center and School, ATTN: MCCS-FCD-L, 1400 East Grayson Street, Fort Sam Houston, Texas 78234-5052.**

e. The use of the term *role of care* in this publication is synonymous with the terms *echelon of care* and *level of care*. The term *echelon of care* is the former NATO term. The term *role of care* is the current NATO and ABCA term.

f. The use of term *casualties* is synonymous with the term *patients*.

g. The term *chemical, biological, radiological, and nuclear (CBRN)* has replaced the term *nuclear, biological, and chemical (NBC)*. The term *NBC* is only used in the fixed terms, names of reports and manuals, and so forth that have not been updated since this change was instituted in doctrine.

h. The use of the term *toxic industrial material (TIM)* in this publication is inclusive of toxic industrial chemical (TIC), toxic industrial biological (TIB), and toxic industrial radiological (TIR) material and radiological dispersal devices (RDDs).

i. The use of the term *health service support* in this publication is synonymous with the term *combat health support* as used in other US Army publications. Health service support is the term used in joint publications (JPs) to describe medical support to joint forces.

j. The medical portion of protection is labeled FHP when focusing on the joint force. It includes all measures to promote, improve, or conserve the mental and physical well-being of Service members.

k. Radiological and chemical detection devices discussed in this publication are currently being replaced through modernization or new device developments. The users should rely on and adapt the application of doctrine as described to fit the new devices when issued/authorized.

l. Unless this publication states otherwise, masculine nouns and pronouns do not refer exclusively to men.

#### 4. Implementation Plan

Participating Service command offices of primary responsibility will review this publication, validate the information, references, and incorporate it in Service and command manuals, regulations, and curricula as follows:

**United States Army.** The US Army will incorporate this publication in US Army training and doctrinal publications as directed by the Commander, US Army Training and Doctrine Command. Distribution is according to initial distribution number 114899 requirements for Field Manual (FM) 4-02.7.

**United States Marine Corps.\*** The US Marine Corps (USMC) will incorporate the procedures in this publication in USMC training and doctrinal publications as directed by the Commanding General, US Marine Corps Combat Development Command. Distribution is according to USMC publication distribution.

**United States Navy.** The US Navy (USN) will incorporate these procedures in USN training and doctrinal publications as directed by the Commander, Navy Warfare Development Command. Distribution is according to Military Standard Requisitioning and Issue Procedures (MILSTRIP) Desk Guide and Navy Supplement Publication 409 (NAVSUP P-409).

**United States Air Force.** The US Air Force (USAF) will validate and incorporate appropriate procedures according to applicable governing directives. Distribution is according to Air Force Instruction (AFI) 33-360.

**United States Coast Guard.** The US Coast Guard (USCG) will validate and refer to appropriate procedures when applicable. No material contained herein should conflict with USCG regulations or other directives from higher authority or supersede or replace any order or directive issued by higher authority.

## **5. User Information**

- a. The US Army Medical Department Center and School. The USAMEDDC&S developed this publication with the joint participation of the approving Service commands.
- b. Service and Joint Doctrine. This publication reflects current Service and joint doctrine on prevention, protection, and medical management of CBRN casualties.
- c. Recommended Changes. We encourage recommended changes for improving this publication. Key your comments to the specific page and paragraph and provide a rationale for each comment or recommendation. Send comments and recommendations directly to—

---

**\*Marine Corps PCN: 144 000168 00**

## Army

Commander  
US Army Medical Department Center and School  
ATTN: MCCA-FCD-L  
1400 East Grayson Street  
Fort Sam Houston, TX 78234-5052  
DSN 471-9411/9524 COMM (210) 221-9411/9524  
E-mail: [medicaldoctrine@amedd.army.mil](mailto:medicaldoctrine@amedd.army.mil)

## \*Marine Corps

Deputy Commandant  
Combat Development and Integration  
ATTN: C116  
3300 Russell Road  
Quantico, VA 22134-5021  
DSN 278-6234 COMM (703) 784-6233  
Web site: <https://www.doctrine.usmc.mil>

## Navy

Commander  
Navy Warfare Development Command  
ATTN: N5  
686 Cushing Road  
Newport, RI 02841-1207  
DSN 948-1070/4201 COMM (401) 841-1070/4201  
E-mail: [alsapubs@nwdc.navy.mil](mailto:alsapubs@nwdc.navy.mil)

## Air Force

Commander  
Air Force Doctrine Center  
ATTN: DR  
155 North Twining Street  
Maxwell AFB, AL 36112-6112  
DSN 493-5645 COMM (334) 953-5645  
E-mail: [afdc.dr2@maxwell.af.mil](mailto:afdc.dr2@maxwell.af.mil)

**\*Marine Corps.** Readers of this publication are encouraged to submit suggestions and changes through the Universal Need Statement (UNS) process. The UNS submission process is delineated in Marine Corps Order 3900.15, Marine Corps Expeditionary Force Development System, which can be obtained from the Marine Corps Publications Electronic Library Online (universal reference locator: <http://www.usmc/directiv.nsf/web+orders>). The UNS recommendation should include the following information:

- Location of change (publication number and title; current page number; paragraph number (if applicable); line number; figure or table number (if applicable)).
- Nature of change (addition/deletion of text; proposed new text).

**This page intentionally left blank.**



\*FM 4-02.7  
MCRP 4-11.1F  
NTTP 4-02.7  
AFTTP 3-42.3

FM 4-02.7 Headquarters, Department of the Army  
Washington, DC  
MCRP 4-11.1F Marine Corps Combat Development Command  
Quantico, Virginia  
NTTP 4-02.7 Navy Warfare Development Command  
Newport, Rhode Island  
AFTTP 3-42.3 Headquarters, Air Force Doctrine Center  
Maxwell Air Force Base, Alabama

15 July 2009

**MULTISERVICE TACTICS, TECHNIQUES, AND PROCEDURES  
FOR  
HEALTH SERVICE SUPPORT IN A CHEMICAL, BIOLOGICAL,  
RADIOLOGICAL, AND NUCLEAR ENVIRONMENT**

**TABLE OF CONTENTS**

	Page
<b>EXECUTIVE SUMMARY .....</b>	<b>xvi</b>
<b>CHAPTER I CHEMICAL, BIOLOGICAL, RADIOLOGICAL, AND NUCLEAR ASPECT OF HEALTH SERVICE SUPPORT .....</b>	<b>I-1</b>
General .....	I-1
Health Threat .....	I-1
Management of Chemical, Biological, Radiological, and Nuclear Casualties .....	I-5
Military Operations in a Chemical, Biological, Radiological, and Nuclear Environment .....	I-13
Health Service Support Planning Considerations .....	I-16
Command, Control, Communications, Computers, and Intelligence Systems in a Chemical, Biological, Radiological, and Nuclear Environment .....	I-17

**DISTRIBUTION RESTRICTION: Approved for public release; distribution is unlimited.**

---

\*This publication supersedes FM 4-02.7 (FM 8-10-7), 1 October 2002.

	Obtaining Medical Intelligence Information on Chemical, Biological, Radiological, and Nuclear Threats .....	I-18
	Joint Warning and Reporting Network .....	I-21
<b>CHAPTER II</b>	<b>CASUALTY PREVENTION .....</b>	<b>II-1</b>
	General .....	II-1
	Medical Surveillance and Occupational and Environmental Health Surveillance Activities .....	II-2
	Medical Countermeasures for Chemical, Biological, Radiological, and Nuclear Casualty Prevention .....	II-2
	Disease Incidence Following the Use of Chemical, Biological, Radiological, and Nuclear Weapons .....	II-3
	Sustainment of Health Service Support Operations in a Chemical, Biological, Radiological, and Nuclear Environment .....	II-5
	Preparation and Training for Chemical, Biological, Radiological, and Nuclear Defense .....	II-6
	Predeployment Procedures .....	II-7
	Predeployment Actions .....	II-8
	Deployment Procedures .....	II-10
	Deployment Actions .....	II-12
	Actions Before a Chemical, Biological, Radiological, and Nuclear Attack .....	II-13
	Actions During a Chemical, Biological, Radiological, and Nuclear Attack .....	II-14
	Actions After a Chemical, Biological, Radiological, and Nuclear Attack .....	II-15
	Other Chemical, Biological, Radiological, and Nuclear Defenses .....	II-16
	Postdeployment Actions .....	II-16
<b>CHAPTER III</b>	<b>CASUALTY CARE AND MANAGEMENT .....</b>	<b>III-1</b>
	General .....	III-1
	Chemical, Biological, Radiological, and Nuclear Mass Casualty .....	III-1
	Triage .....	III-5
	Mission-Oriented Protective Posture Levels .....	III-7
	Civilian Casualties .....	III-7
	Taxonomy of Care .....	III-7
	Roles of Care .....	III-9
	Role 1 Health Service Support in a Chemical, Biological, Radiological, and Nuclear Environment .....	III-10
	Role 2 Health Service Support in a Chemical, Biological, Radiological, and Nuclear Environment .....	III-11
	Role 3 Health Service Support in a Chemical, Biological, Radiological, and Nuclear Environment .....	III-12

	Management of Chemical, Biological, Radiological, and Nuclear Casualties in a Medical Treatment Facility.....	III-13
	United States Marine Corps Operations Casualty Management.....	III-14
	Protection of Medical Treatment Facilities .....	III-15
	Chemical Environment.....	III-16
	Biological Environment .....	III-18
	Nuclear Environment .....	III-20
	Medical Treatment Facility Contamination Control .....	III-21
	Medical Treatment Facility Decontamination .....	III-25
	Training and Exercises .....	III-27
	Restriction of Movement, Isolation, and Quarantine .....	III-28
	Worried Well .....	III-28
<b>CHAPTER IV</b>	<b>PATIENT MOVEMENT.....</b>	<b>IV-1</b>
	General .....	IV-1
	Medical Evacuation in a Chemical, Biological, Radiological, and Nuclear Environment.....	IV-1
	Medical Air Evacuation Under High Level Biosafety Containment .....	IV-4
	Aeromedical Evacuation Process .....	IV-5
	Patient Isolation Unit.....	IV-6
<b>CHAPTER V</b>	<b>PATIENT DECONTAMINATION.....</b>	<b>V-1</b>
	General .....	V-1
	Levels of Decontamination .....	V-2
	The Importance of Early Contaminant Removal and Medical Monitoring of Patients.....	V-3
	Zones of Contamination.....	V-6
	Personal Protective Equipment Worn by Decontamination Operators.....	V-7
	Decontamination Materials .....	V-9
	Detection Devices Used During Patient Decontamination.....	V-13
	Safety, Heat Injury Prevention, and Water Consumption .....	V-14
	Heat Injury .....	V-15
	Core Components of the Patient Decontamination Site and Patient Flow.....	V-17
	Collocating a Land-Based Patient Decontamination Operation with Troop Decontamination Operations .....	V-22
	Litter Patient Mask, Protective Ensemble, and Clothing Removal Procedures.....	V-23
	Ambulatory Patient Mask, Protective Ensemble, and Clothing Removal Procedures.....	V-30
	Wound Decontamination and Trauma Management Procedures .....	V-34
	Establishing a Patient Decontamination Site .....	V-35
	Actions to Take Upon Notification of Patient Arrival .....	V-44

Actions to Take When Contaminated Patients Arrive.....	V-44
Moving a Litter Patient Through a Patient Decontamination Site .....	V-45
Clothing Removal Station .....	V-48
Decontaminate the Patient .....	V-49
Check Patient for Completeness of Decontamination .....	V-51
Movement of the Patient to the Hot Line .....	V-51
Movement of the Patient on the Clean Side of the Hot Line.....	V-53
Moving an Ambulatory Patient Through Patient Decontamination .....	V-53
Processing Through the Ambulatory Decontamination Line.....	V-55
Procedures for Closing Down a Patient Decontamination Site .....	V-57
Equipment and Supply Recovery .....	V-58
Decontamination Team Personnel Recovery (Technical Decontamination) .....	V-59
Establishing a Patient Decontamination Station on a Water Vessel.....	V-60
Actions to Take Prior to Arrival of Patients .....	V-61
Procedures to be Performed on the Flight Deck.....	V-64
Moving a Litter Patient Through a Patient Decontamination Station on a Water Vessel.....	V-66
Procedures to be Performed in First Compartment .....	V-67
Procedures to be Performed in Second (Monitoring) Compartment.....	V-68
Procedures for Decontaminating the Facility and the Decontamination Team .....	V-70
Moving an Ambulatory Patient Through a Patient Decontamination Station on a Water Vessel.....	V-72
Procedures For Closing Down the Patient Decontamination Station on Board a Water Vessel .....	V-74
Night Operations.....	V-75
Activities during Night Operations.....	V-76
Cold Weather Operations .....	V-78

**CHAPTER VI**

<b>VETERINARY SERVICE SUPPORT AND FOOD AND WATER SAFETY .....</b>	<b>VI-1</b>
General.....	VI-1
Veterinary Service Support.....	VI-1
Food Safety and Security and Quality Assurance .....	VI-2
Veterinary Medical Care .....	VI-3
Veterinary Preventive Medicine .....	VI-3
Veterinary Unit Operations in a CBRN Environment .....	VI-4
Veterinary Support for Subsistence .....	VI-5
Veterinary Survey of Storage Facilities and Subsistence .....	VI-5

Testing, Screening, and Collecting Food Samples in the Field.....	VI-6
Subsistence Decontamination .....	VI-7
Treatment of Military Working Dogs Exposed to a Chemical, Biological, Radiological, and Nuclear Environment .....	VI-8
Protection Against Nerve Agents .....	VI-10
Signs of Nerve Agent Intoxication in Military Working Dogs .....	VI-10
Nerve Agent Decontamination Procedures .....	VI-11
Treatment of Military Working Dog Casualties of Nerve Agents .....	VI-12
Protection Against Incapacitating Agents (BZ Type) .....	VI-14
Protection Against Blister Agents .....	VI-15
Lung-Damaging Agents (Choking Agents) .....	VI-18
Cyanide Compounds (Blood Agents) .....	VI-18
Biological Warfare Agents .....	VI-19
Nuclear and Radiological Weapons.....	VI-20
Water Safety and Management.....	VI-20
Detection of Contaminated Water.....	VI-21
Treatment of Contaminated Water .....	VI-22
Engineer Support.....	VI-22

**CHAPTER VII**

<b>MEDICAL LABORATORY SUPPORT .....</b>	<b>VII-1</b>
General .....	VII-1
Samples/Specimen Collection and Management of Chemical, Biological, Radiological, and Nuclear Contaminants .....	VII-2
Handling and Storage of Samples Within the Laboratory .....	VII-5
Confidence Levels of Laboratory Analysis .....	VII-6
Joint Biological Agent Identification and Diagnostic System .....	VII-7
Operational Employment .....	VII-9
Nationally Recognized Reference Laboratories (Definitive) .....	VII-10
Other Department of Defense Laboratories.....	VII-11
Laboratory Response Network .....	VII-12

**CHAPTER VIII**

<b>COMBAT AND OPERATIONAL STRESS CONTROL .....</b>	<b>VIII-1</b>
General .....	VIII-1
Combat and Operational Stress Reaction .....	VIII-1
Combat and Operational Stress Control Under Reactions .....	VIII-3
Combat and Operational Stress Reaction Leader Risks .....	VIII-3
Combat and Operational Stress Reaction Leadership Actions.....	VIII-3
Individual Responsibilities.....	VIII-5
Behavioral Health Personnel Responsibilities .....	VIII-5
Conducting Combat and Operational Stress Control in a CBRN Environment .....	VIII-5

<b>CHAPTER IX</b>	<b>HEALTH SERVICE LOGISTICS SUPPORT .....</b>	<b>IX-1</b>
	General .....	IX-1
	Logistics Support in a Chemical, Biological, Radiological, and Nuclear Environment.....	IX-1
	Health Service Logistics Support Considerations in a Chemical, Biological, Radiological, and Nuclear Environment .....	IX-2
	Protecting Supplies in Storage .....	IX-3
	Protecting Supplies During Shipment.....	IX-3
	Movement Control .....	IX-3
<b>CHAPTER X</b>	<b>HOMELAND DEFENSE.....</b>	<b>X-1</b>
	General.....	X-1
	Homeland Defense Chemical, Biological, Radiological, and Nuclear Response.....	X-1
	United States Army Role in Homeland Defense.....	X-3
	United States Army National Guard Role .....	X-3
	United States Army Reserve Role .....	X-5
	United States Coast Guard National Strike Force Role.....	X-6
	United States Navy Medicine Role .....	X-7
	United States Marine Corps Role .....	X-7
	United States Air Force Role .....	X-8
	Other Department of Defense Response Assets (Not Inclusive) .....	X-8
<b>CHAPTER XI</b>	<b>INDIVIDUAL AND COLLECTIVE PROTECTION SYSTEMS .....</b>	<b>XI-1</b>
	General.....	XI-1
	Types of Collective Protection Systems .....	XI-2
	Collectively Protected Field Hospital .....	XI-4
	The Joint Expeditionary Collective Protection Program .....	XI-6
	Employment of the Chemical Biological Protective Shelter System .....	XI-7
	Brigade Support Medical Company Role 2 Medical Treatment Facility in a Chemical Biological Protective Shelter .....	XI-9
	Forward Surgical Team in a Chemical Biological Protective Shelter .....	XI-10
	Employment of the Chemically Protected Deployable Medical Systems and Simplified Collective Protection Systems.....	XI-12
	Chemically/Biologically Protecting the International Organization for Standardization Shelter .....	XI-17
	Chemically/Biologically Protecting the Vestibules .....	XI-17
	Chemically/Biologically Protecting Air Handler Equipment.....	XI-17
	Establish Collective Protection Shelter Using the M20 Simplified Collective Protection System .....	XI-17

	Patient Decontamination.....	XI-18
	Operations, Entry, and Exit Guidelines.....	XI-18
	Decontamination of Entrance Area.....	XI-18
	Entry/Exit for the Collective Protection Shelter System.....	XI-19
<b>APPENDIX A</b>	<b>CHEMICAL, BIOLOGICAL, RADIOLOGICAL, AND NUCLEAR CASUALTY ESTIMATION .....</b>	<b>A-1</b>
	Decision Support Tool .....	A-1
	Casualty Estimates .....	A-1
	Joint Effects Model .....	A-1
	Joint Operational Effects Federation Model.....	A-2
<b>APPENDIX B</b>	<b>HEALTH SERVICE SUPPORT CHEMICAL, BIOLOGICAL, RADIOLOGICAL, AND NUCLEAR ANNEX TO AN OPERATION PLAN/OPERATION ORDER.....</b>	<b>B-1</b>
	Medical Chemical, Biological, Radiological, and Nuclear Staff Officer Planning for Health Service Support in a Chemical, Biological, Radiological, and Nuclear Environment .....	B-1
	Sample Format for the Health Service Support Plan for Chemical, Biological, Radiological, and Nuclear Operations.....	B-2
<b>APPENDIX C</b>	<b>SERVICE-SPECIFIC TASKS LIST .....</b>	<b>C-1</b>
	United States Army Tasks List.....	C-1
	United States Air Force Tasks List .....	C-4
	United States Navy Tasks List.....	C-8
	United States Marine Corps Tasks List .....	C-9
<b>APPENDIX D</b>	<b>SERVICE-SPECIFIC CHEMICAL, BIOLOGICAL, RADIOLOGICAL, AND NUCLEAR DEFENSE CAPABILITIES.....</b>	<b>D-1</b>
	Service-Specific Chemical, Biological, Radiological, and Nuclear Defense Capabilities Descriptions .....	D-1
	United States Army Chemical, Biological, Radiological, and Nuclear Defense Capabilities .....	D-1
	United States Marine Corps Chemical, Biological, Radiological, and Nuclear Defense Capabilities.....	D-4
	United States Navy Chemical, Biological, Radiological, and Nuclear Defense Capabilities .....	D-6
	United States Air Force Deployable Teams Related to the Medical Chemical, Biological, Radiological, and Nuclear Defense.....	D-7
	Technical Reachback .....	D-10
<b>REFERENCES</b>	.....	<b>References-1</b>
<b>GLOSSARY</b>	.....	<b>Glossary-1</b>
<b>INDEX</b>	.....	<b>Index-1</b>

## FIGURES

Figure IV-1. Patient Isolation Unit Roles of Care Operational Concept .....	IV-7
Figure V-1. Patient Decontamination Site Layout .....	V-6
Figure V-2. Cutline for Hoods Integral to Overgarments .....	V-24
Figure V-3. Cutline for Hoods Attached to Mask .....	V-24
Figure V-4. Cutline for Overgarment Jacket.....	V-26
Figure V-5. Cutline for Overgarment Trousers .....	V-27
Figure V-6. Outer Gloves Removal .....	V-28
Figure VII-1. Levels of Identification Confidence.....	VII-7
Figure VII-2. The “New” Laboratory Reference Network Designation .....	VII-13
Figure XI-1. Chemical Biological Protective Shelter System.....	XI-7
Figure XI-2. Battalion Aid Station Using the Chemical Biological Protective Shelter.....	XI-9
Figure XI-3. Chemical Biological Protective Shelter Configuration as a Brigade Support Medical Company Role 2 Medical Treatment Facility .....	XI-10
Figure XI-4. Forward Surgical Team Configuration for Operations in Conventional Mode .....	XI-11
Figure XI-5. Forward Surgical Team and Brigade Support Medical Company Role 2 Medical Treatment Facility Configuration for Operations in a Chemical, Biological, Radiological, and Nuclear Environment .....	XI-12
Figure XI-6. Sample Layout of a Medical Force 2000 Combat Support Hospital (Unit Base) Employing Chemically Protected Deployable Medical System .....	XI-14
Figure XI-7. Sample Layout of an 84-Bed Medical Reengineering Initiative Hospital Employing Chemically Protected Deployable Medical System.....	XI-15
Figure XI-8. Sample Layout of a 164-Bed Medical Reengineering Hospital Employing Chemically Protected Deployable Medical System.....	XI-16

## TABLES

Table I-1. Nations Known or Suspected of Possessing Chemical Weapons .....	I-2
Table I-2. Chemical Warfare Agents .....	I-2
Table I-3. Examples of Known or Suspected Biological Warfare Agents .....	I-3
Table I-4. The Future of Biological Warfare Agents .....	I-3
Table I-5. Countries Possessing or Suspected of Possessing Nuclear Weapons .....	I-4
Table III-1. Troop Decontamination Levels and Responsible Unit .....	III-4
Table III-2. Patient Decontamination Levels and Responsible Element. ....	III-5



Table IV-1. Contagious Diseases .....	IV-8
Table V-1. General Recommended Decontamination Actions by Type and Category of Agent .....	V-5
Table V-2. General Chemical, Biological, Radiological, and Nuclear Decontaminants/Hazard Mitigation Techniques and Applications.....	V-8
Table V-3. Summary of Appropriate Uses for Decontaminants.....	V-12
Table V-4. Work/Rest Cycles and Water Consumption (Without Protective Ensemble).....	V-16
Table V-5. Suggested Minimal Staffing for One Work Cycle .....	V-37
Table V-6. Equipment and Supplies Needed for a Decontamination Lane .....	V-43
Table V-7. Equipment and Supplies Required for the Contamination Check Area at a Patient Decontamination Site With Minimal Equipment.....	V-43
Table V-8. Equipment and Supplies Required for the Hot Line at a Patient Decontamination Site With Minimal Equipment .....	V-44
Table V-9. Equipment and Supplies Required for the Closure/Disestablishment of a Patient Decontamination Site .....	V-58
Table V-10. Minimal Staffing for One Work Cycle at a Patient Decontamination Site on a Water Vessel.....	V-64
Table V-11. Equipment and Supplies Required for Patient Decontamination Procedures Conducted on the Flight Deck .....	V-65
Table V-12. Equipment and Supplies Required for Patient Decontamination Procedures Conducted in First Compartment.....	V-65
Table V-13. Stages and Symptoms of Hypothermia .....	V-80
Table V-14. Decontamination Methods Based on Ambient Temperature .....	V-81
Table VI-1. Environmental Factors—Temperate Regions .....	VI-23
Table VI-2. Environmental Factors—Tropical Regions .....	VI-24
Table VI-3. Environmental Factors—Frigid Climates .....	VI-24
Table VI-4. Environmental Factors—Arid Regions .....	VI-24
Table D-1. Technical Reachback Points of Contact .....	D-11

## **EXECUTIVE SUMMARY**

### **Multiservice Tactics, Techniques, and Procedures for Health Service Support in a Chemical, Biological, Radiological, and Nuclear Environment**

#### **Chapter I**

##### **Chemical, Biological, Radiological, and Nuclear Aspect of Health Service Support**

Chapter I discusses the current policy, health threat, and HSS planning considerations in a CBRN environment.

#### **Chapter II**

##### **Casualty Prevention**

Chapter II discusses medical surveillance and occupational and environmental health surveillance activities and predeployment, deployment, and postdeployment activities.

#### **Chapter III**

##### **Casualty Care and Management**

Chapter III discusses CBRN mass casualty, triage, taxonomy of care, roles of care, and medical treatment facility (MTF) activities.

#### **Chapter IV**

##### **Patient Movement**

Chapter IV discusses medical evacuation in CBRN environment, medical evacuation under high level biosafety containment, patient isolation unit, and medical evacuation capabilities.

#### **Chapter V**

##### **Patient Decontamination**

Chapter V discusses levels of decontamination, zones of contamination, safety, and the patient decontamination process.

#### **Chapter VI**

##### **Veterinary Service Support and Food and Water Safety**

Chapter VI discusses food protection, food defense, support for subsistence, medical and treatment care for government-owned animals/military working dogs (MWDs), and water safety and management.

## **Chapter VII**

### **Medical Laboratory Support**

Chapter VII discusses samples/specimen collection and management of CBRN contaminants, handling and storage of sample within the laboratory, confidence levels of laboratory analysis, joint biological agent identification and diagnostic system, definitive laboratories, other DOD laboratories and the laboratory response network.

## **Chapter VIII**

### **Combat and Operational Stress Control**

Chapter VIII discusses combat and operational stress reaction, combat and operational stress control under reactions, combat and operational stress reaction leader risks and actions, individual responsibilities, behavioral health personnel responsibilities, and conducting combat and operational stress control in a CBRN environment.

## **Chapter IX**

### **Health Service Logistics Support**

Chapter IX discusses logistics support in a CBRN environment, HSLS considerations in a CBRN environment, protecting supplies in storage and during shipment, and movement control.

## **Chapter X**

### **Homeland Defense**

Chapter X discusses homeland defense CBRN response, US Army role, US Coast Guard role, US Navy role, US Marine Corps role, US Air Force role, and other DOD response assets.

## **Chapter XI**

### **Individual and Collective Protection Systems**

Chapter XI discusses types of collective protection systems, collectively protected field hospital, joint expeditionary collective protection (JECP), employment of the chemical biological protective shelter system, brigade support medical company Role 2 MTF in a chemical biological protective shelter, forward surgical team in a chemical biological protective shelter, the employment of the chemically protected deployable medical system (CPDEPMEDS), chemically/biologically protecting the International Organization for Standardization (ISO) shelter, and establish collective protection shelter using the M20 simplified collective protection system.

## **PROGRAM PARTICIPANTS**

The following commands and agencies participated in the development of this publication:

### **Army**

United States Army Office of The Surgeon General, 5111 Leesburg Pike, Ste. 401, Falls Church, VA 22041-3258

United States Army Center for Health Promotion & Preventive Medicine, 5158 Blackhawk Road, Aberdeen Proving Ground, MD 21010-5403

United States Army Medical Research Institute of Infectious Diseases, 1425 Porter Street, Frederick, MD 21702-5011

United States Army Medical Research Institute of Chemical Defense, 3100 Ricketts Point Road, Aberdeen Proving Ground, MD 21010-5400

### **Marine Corps**

United States Marine Corps Combat Development Command, ATTN: C42 (Director) 3300 Russell Road, Quantico, VA 22134-5021

### **Navy**

United States Navy Warfare Development Command, ATTN: N5, 686 Cushing Road, Newport, RI 02841-1207

### **Air Force**

Headquarters Air Force Doctrine Center, ATTN: DR, 155 North Twining Street, Maxwell AFB, AL 36112-6112

# Chapter I

## CHEMICAL, BIOLOGICAL, RADIOLOGICAL, AND NUCLEAR ASPECT OF HEALTH SERVICE SUPPORT

### 1. General

a. Planning for military operations at all levels inherently includes provisions for adequate FHP and HSS. Commanders are responsible for the maintenance of the health of their commands to ensure mission accomplishment in the event of CBRN attacks. Maintaining the physiological and psychological health of military forces is a basic requirement for combat effectiveness. The JFC at all levels is faced with the possibility that any operation may have to be conducted in a CBRN environment.

b. The term CBRN environment includes the deliberate or accidental employment or threat of CBRN weapons and attacks with TIM. The employment or threat of CBRN weapons and other toxic materials pose challenges to US military operations worldwide. Responsibility for operations in any theater involves peacetime preparations and transition to operations with forces from areas outside the theater, including other theaters and the US, and inherently involves joint, multinational, and interagency dimensions. Medical forces including Table of Distribution and Allowance (TDA) fixed facilities and teams as well as table of organization and equipment (TOE) units may be required to operate in a CBRN environment.

c. The JFC must plan and integrate US and multinational force capabilities to sustain the operational tempo in all mediums (air, sea, land, and space). The component command surgeons, working with the appointed joint force surgeon (JFS), are responsible for guiding and integrating all HSS capabilities available to the command to support mission accomplishment in a CBRN environment. In planning for FHP and HSS in potential CBRN environments, preparations should include preexposure immunizations, pretreatments, prophylaxis, and medical barrier materials applicable to the entire force, including multinational, interagency, and civilian participants. Basic doctrine for joint HSS operations is contained in JP 4-02 and JP 3-11.

### 2. Health Threat

a. Agents, Weapons, and Devices that Produce Health Threats. The health threat is a composite of ongoing or potential enemy actions; adverse environmental, occupational, and geographic and meteorological conditions; endemic diseases; and employment of nuclear, biological, and chemical weapons (to include weapons of mass destruction) that have the potential to affect the short- or long-term health (including psychological impact) of personnel. Service members are the targets of these threats. Weapons or environmental conditions that will generate wounded, injured, and sick Service members beyond the capability of the HSS system to provide timely medical care from available resources, are considered major health threats. Weapons or environmental conditions that produce qualitatively different wound or disease processes are also considered major health threats. Added to the combat and operational, environmental, disease and nonbattle injury (DNBI), and stress health threats are the adversary use of the following types of weapons, agents, and devices—

- (1) Chemical warfare (CW) agents.
- (2) Biological warfare (BW) agents.

- (3) Radiological dispersal devices.
- (4) Nuclear weapons.
- (5) Toxic industrial materials.
- (6) Directed-energy (DE) devices/weapons.

b. Chemical Warfare.

(1) Many nations view an offensive CW capability as a reasonable and affordable deterrent to the military advantage of a potential adversary. Table I-1 lists those countries known or suspected of having offensive chemical weapons.

**Table I-1. Nations Known or Suspected of Possessing Chemical Weapons**

<i>Known to Possess</i>	<i>Suspected of Possessing</i>
United States of America	People's Republic of China
Russia	North Korea
India	Egypt
Iraq	Israel
Iran	Ethiopia
Syria	Taiwan
Yugoslavia (Serbia & Montenegro)	Burma
	Libya
	Algeria
	South Korea
	South Africa
	Kazakhstan
	Pakistan

(2) The Russian Republic has the most extensive CW capability in Europe. Chemical strikes can be delivered with almost any type of conventional fire support weapons systems (from mortars to long-range tactical missiles). Agents known to be available in the Russian inventory include nerve agents (O-ethyl S-[2-diisopropylaminoethyl] methylphosphonothiolate [VX], thickened VX, sarin [GB], and thickened soman [GD]); vesicants (thickened Lewisite [L] and mustard-Lewisite mixture [HL]); and choking agent (phosgene [CG]). Although not considered CW agents, riot control agents are also in the Russian inventory. Table I-2 provides a list of known CW agents.

**Table I-2. Chemical Warfare Agents**

<i>Nerve</i>	<i>Vesicant</i>	<i>Incapacitating</i>	<i>Choking</i>	<i>Blood</i>
Tabun (GA)	Sulfur Mustard (HD)	3-quinuclidinyl benzilate (BZ)	Phosgene (CG)	Hydrogen Cyanide (AC)
Sarin (GB)	Mustard-Lewisite mixture (HL)	Chloropicrin (PS)	Diphosgene (DP)	Cyanogen Chloride (CK)
Soman (GD)	Lewisite (L)	D-Lysergic Acid Diethylamide (LSD)	Chlorine (Cl)	
Cyclosarin (GF)	Phosgene Oxime (CX)			
O-ethyl S-(2-diisopropylaminoethyl) methylphosphonothiolate (VX)				

(3) The US and various other countries noted in Table I-1 are in the process of destroying their stockpiles of CW weapons. Many weapons have already been destroyed and the storage facilities have been rendered safe of all CW agent residues.

c. Biological Warfare.

(1) Biological warfare is defined by the US intelligence community as the intentional use of disease-causing organisms (pathogens), toxins, or other agents of biological origin (ABOs) to incapacitate, injure, or kill humans and animals; to destroy crops; to weaken resistance to attack; and to reduce the will to fight. Historically, BW has primarily involved the use of pathogens in assassinations or as sabotage agents in food and water supplies to spread disease among target populations.

(2) For purposes of health threat assessment, we are interested only in those BW agents that incapacitate, injure, or kill humans or animals.

(3) Known or suspected BW agents and ABOs can generally be categorized as naturally occurring, unmodified infectious agents (pathogens); toxins, venoms, and their biologically active fractions; modified infectious agents; and bioregulators. See Table I-3 for examples of known or suspected BW agents. Table I-4 also presents possible developmental BW agents.

**Table I-3. Examples of Known or Suspected Biological Warfare Agents**

<i>Pathogens</i>	<i>Toxins</i>
<i>Bacillus anthracis</i> (Anthrax)	Botulinum Toxin
<i>Francisella tularensis</i> (Tularemia)	Mycotoxins
<i>Yersinia pestis</i> (Plague)	Enterotoxins
<i>Brucella species</i> (Brucellosis)	Ricin
<i>Vibrio cholerae</i> (Cholera)	
<i>Variola species</i> (Smallpox)	
Viral Hemorrhagic Fevers	

(4) Many governments recognize the industrial and economic potential of advanced biotechnology and bioengineering. The same knowledge, skills, and methodologies can be applied to the production of second and third generation BW agents. Naturally occurring infectious organisms can be made more virulent and antibiotic resistant and manipulated to render protective vaccines ineffective. These developments complicate the ability to detect and identify BW agents and to operate in areas contaminated by the BW agents. The first indication that a BW agent release/attack has occurred may be casualties presenting at an MTF with symptoms not fitting the mold for endemic diseases in the area of operations (AO). See Chapter VII for sampling requirements, sampling procedures, packaging and shipping, and chain of custody requirements.

**Table I-4. The Future of Biological Warfare Agents**

<i>Current Threat</i>	<i>Future</i>
Pathogens Limited number of Toxins Agents of Biological Origin	Modified Pathogens Expanded Range of Toxins (Organo-Toxins) Protein Fractions Agents of Biological Origin

d. Nuclear Weapons and Radiological Dispersal Device Threats.

(1) Available information suggests that a number of countries in the Middle East, Asia, and Africa have or may have nuclear weapons capability within the next decade. Table I-5 lists those countries known to have or are suspected of possessing and/or seeking nuclear weapons.

(2) Medical planners can expect, as a minimum, 10 to 20 percent casualties within a division-sized force that has experienced a nuclear strike. In addition to the casualties, a nuclear weapon detonation can generate an electromagnetic pulse (EMP) that will cause catastrophic failures of electronic equipment components. Radiological dispersal devices are comprised of an explosive device with radioactive material which can be detonated without the need for the components of a nuclear weapon. The RDD can disperse radioactive material over an area of the battlefield causing effects from nuisance levels of radioactive material to life-threatening levels without the thermal and, in most cases, the blast effects of a nuclear detonation.

**Table I-5. Countries Possessing or Suspected of Possessing Nuclear Weapons**

<i><b>Known to Possess</b></i>	<i><b>Suspect or Seeking</b></i>
United States of America Russia Israel People's Republic of China France United Kingdom Pakistan India Iran	Libya North Korea

e. Toxic Industrial Materials.

(1) Toxic industrial materials can present a health threat to deployed forces. Toxic industrial materials is a broad term used to refer to hazardous commercial materials or substances to include TICs as well as commercially generated/used biological and radiological materials and or wastes. These materials are found throughout the world and are used on a daily basis for commercial and private purposes. Large storage facilities, transportation tankers (over the road and railcars), as well as smaller containers of materials, pose a danger to the health of civilians and military personnel.

(2) Accidental spills or releases and terrorist actions can all lead to the release of these materials into the environment causing potential casualty-producing effects. Medical treatment facilities and nuclear power plants use radioactive materials that can pose a health hazard if accidentally released or used by hostile forces, terrorists, or others to contaminate an area. Biological materials used in medical research and pharmaceutical manufacturing may also be used to produce casualties.

(3) Toxic industrial chemicals of particular concern to the military are common commercially produced chemicals that pose a risk of severe and immediate (acute) adverse health effects from a single release event. The degree of risk is dependent on the severity of effects and the probability that the TIC may be obtained and/or released in large quantities. Over the last few years various military efforts have identified the most critical TICs of concern; examples include chlorine, ammonia, sulfur dioxide, as well as chemicals



that have also been classified and warfare agents such as hydrogen cyanide and phosgene. Ongoing efforts continue to improve military materiel and procedural defensive measures against these TIC threats. However, it is acknowledged that the current detection, protection, and medical equipment and procedures for TICs are still inadequate. For current doctrine regarding these threats see FM 3-11.21/Marine Corps Reference Publication (MCRP) 3-37.2C/Navy Tactics, Techniques, and Procedures (NTTP) 3-11.24/Air Force Tactics, Techniques, and Procedures (Interservice) (AFTTP[I]) 3-2.37 and FM 3-11-4 (FM 3-4)/Marine Corps Warfighting Publication (MCWP) 3-37.2/NTTP 3-11.27/AFTTP (I) 3-2.46. For additional specific guidance and references contact United States Army Center for Health Promotion and Preventive Medicine (USACHPPM) or see USACHPPM Deployment Health Guide: Toxic Industrial Chemicals (TIC) Release Response (<http://chppm-www.apgea.army.mil/documents/Disaster/TICResponse2.pdf>).

f. Directed-Energy Devices/Weapons.

(1) Directed-energy weapons are weapons that direct energy by means other than a projectile in a particular direction. It transfers energy to a target for a desired effect and take the form of lasers, high-powered microwaves, and particle beams.

(2) In recent events, laser pointers have come to the public's attention since the Federal Aviation Administration reported more than 150 incidents in which aircrafts were illuminated by lasers. The likelihood of lasers being pointed at commercial and military airline pilots during takeoff and landing has raised concerns that this may be an inexpensive form of device which could be used by terrorists.

### **3. Management of Chemical, Biological, Radiological, and Nuclear Casualties**

a. Chemical Warfare Agent. Health service support operations in a CW environment are complex. In addition to providing care in protected environments or while dressed in protective clothing, medical personnel will have to treat chemically injured and contaminated casualties in large numbers. Types of injuries associated with CW are—

(1) Nerve agent injury. Nerve agent injuries are classified as mild and severe. Classification is based on the signs and symptoms presented by the individual. The individual may only be having minor problems (such as miosis) or may be convulsing and exhibiting severe respiratory distress. Some individuals can return to duty (RTD) after receiving a single injection of the Mark I/antidote treatment—nerve agent, autoinjector (ATNAA); others may require three doses of the Mark I/ATNAA followed by convulsant antidote for nerve agent (diazepam) (CANAA) and assisted ventilation. Additionally, some individuals may require more doses of atropine once they reach an MTF. For more information on nerve agent antidote, see FM 4-02.285 (FM 8-285)/MCRP 4-11.1A/Navy Tactics, Techniques, and Procedures (NTRP) 4-02.22/AFTTP (I) 3-2.69.

(2) Blister agent injury. Individuals exposed to blister agents may not know that they have been exposed to the agent for hours or days later. The first indication of exposure may be small blisters on the skin. Others will have immediate burning because of a high level of exposure. The individual with a few small blisters or reddening of the skin can continue the mission. An individual suffering mild injuries may require admission to an MTF for treatment, then RTD; whereas, the individual with severe injuries may have to be evacuated from the theater.

(3) Incapacitating agent injury. Incapacitating agents produce injury by depressing or stimulating the central nervous system (CNS). These agents affect the CNS by disrupting the high integrative functions of memory, problem solving, attention, and

comprehension. Relatively high doses produce toxic delirium, which destroys the ability to perform any task.

(4) Cyanogen (blood) agent injury. Cyanogen agents produce their effects by interfering with oxygen use at the cellular level. The agent prevents the oxidative process within cells. In high concentrations, there is an increase in the depth of respiration within a few seconds. The casualty cannot voluntarily hold his breath. Violent convulsions occur after 20 to 30 seconds with cessation of respiration within 1 minute. Cardiac failure follows within a few minutes. Inhalation is the usual route of entry.

(5) Lung-damaging agent injury. Lung-damaging (choking) agents attack lung tissue, primarily causing pulmonary edema. The principle agents in this group are phosgene (CG), diphosgene (DP), chlorine (Cl), and chloropicrin (PS).

b. Management of Chemical Agent Casualties. Movement of CW agent casualties can spread the contamination to clean areas. All casualties are decontaminated as far forward as the situation permits. All casualties must be decontaminated before they are admitted into a clean MTF. The admission of one contaminated casualty into an MTF will contaminate the facility; thereby, reducing treatment capabilities in the facility.

(1) Mass Casualty. As with other CBRN weapons, a mass casualty situation may result when CW agents are employed. Additional HSS personnel and equipment must be provided quickly if the level of care is to be maintained. Treatment at far forward MTFs is limited to life- or limb-saving care. Casualties that can survive evacuation to the next role of care are not treated at the forward facility. This provides time for treating those casualties that cannot survive the evacuation. Refer to Appendix A for CBRN casualty estimation.

(2) Decontamination. Decontamination of chemically contaminated casualties requires the removal of their contaminated clothing and the use of a variety of decontamination kits and solutions. See Chapter V for details on patient decontamination.

(3) Treatment. Field Manual 4-02.285 (FM 8-285)/MCRP 4-11.1A/NTRP 4-02.22/AFTTP (I) 3-2.69 provides additional information on treatment procedures for CW agent casualties.

c. Biological Warfare Agent. The impact of BW on HSS may be as simple as a few casualties with diarrhea or as complex as a mass casualty situation. Biological warfare agents are most likely to be delivered covertly and by aerosol. Most BW agents have a long incubation period from onset to clinical symptoms compared with CW agents. For these reasons, the first indication of a BW attack will most likely be casualties arriving at an MTF with an illness. The primary route of entry for BW agents is by inhalation. However, other routes include ingestion and percutaneous inoculation.

(1) Aerosol.

(a) Inhalation. Inhalation of agent aerosols, with resultant deposition of infectious or toxic particles within alveoli, provides a direct pathway to the systemic circulation. The process of breathing causes a continuing flux of BW agent to exposed individuals. The major risk is pulmonary retention of inhaled particles. Droplets as large as 20 microns can infect the upper respiratory tract; however, natural anatomic and physiological processes generally filter these relatively large particles and only much smaller particles (ranging from 0.5 to 5 microns) reach the alveoli efficiently.

(b) Ingestion. Food and water supplies may be contaminated during an aerosol BW attack. Unwary consumption of such contaminated materials could result

in disease. Inhaled aerosols also lead to agent being ingested as particles trapped in the respiratory tract and will eventually be swallowed.

(c) Percutaneous. Intact skin provides an excellent barrier for most, but not all, BW agents. However, mucous membranes and damaged skin constitute breaches in this normal barrier through which BW agents may readily pass.

(2) Contamination of food and water. Direct contamination of food and water could be used as a means to disseminate infectious agents or toxins. This method of attack is most suitable for sabotage activities and might be used against limited targets such as water supplies or food supplies of a specific unit or base.

(3) Other considerations.

(a) Arthropodborne. The spread of diseases may be accomplished by releasing infected arthropods such as mosquitoes, ticks, or fleas. These live vectors can be produced in large numbers and infected by allowing them to feed on infected animals, infected blood reservoirs, or artificially produced sources of a BW agent.

(b) Long-term survival of infectious agents. Preservation of toxins for extended periods and the protective influence of dust particles onto which microorganisms adsorb when spread by aerosols have been documented. Therefore, the potential exists for the delayed generation of secondary aerosols from contaminated surfaces. To a lesser extent, particles may adhere to an individual or to clothing, creating additional exposure hazards.

(c) Person-to-person contact. The spread of potential BW agents by person-to-person contact has been documented. Man, as an unaware and highly effective carrier of a communicable agent, could readily become a source of dissemination (for example, plague or smallpox).

d. Management of Biological Warfare Casualties. Biologically contaminated casualties require decontamination before admission into an MTF. Casualties suspected of suffering from exposure to BW agents may require isolation or quarantine to reduce the possibility of spreading the disease to health care providers and other casualties. Specimens must be collected and submitted to the designated supporting laboratory for identification to determine if infectious disease isolation precautions are necessary.

(1) Mass casualty. A BW agent attack can produce a mass casualty situation at all roles of care. Therefore, HSS planners must ensure that mass casualty situations are included in HSS plans.

(2) Decontamination. Majority of casualties presenting to the MTF with symptoms or disease due to BW agent exposure will not require decontamination; during the delay between BW agent exposure and onset of symptoms external contamination would likely have dissipated to a large degree. Contamination can be removed by use of soap and water, which is the most preferred method. See Chapter V for details on patient decontamination.

(3) Treatment. Treatment is dependent upon the BW agent used. Casualties are treated as described in FM 8-284/NTRP 4-02.23 (Navy Medical [NAVMED] P-5042)/Air Force Manual (Interservice) (AFMAN [I]) 44-156/MCRP 4-11.1C.

e. Radiologically Contaminated Casualties. Casualties from fallout areas may have contamination on their skin and clothing. Removal of the contamination should be accomplished as soon as possible, but definitely before admission into a clean treatment area. The distinction must be made between radiation-injured casualties and those that are

radiologically contaminated. Although casualties may have received substantial radiation exposure, this exposure alone does not result in the individual being contaminated. Normally, contaminated casualties do not pose a short-term hazard to the medical staff; rather the contamination is a hazard to the casualty's health. However, without casualty decontamination, medical personnel may receive sufficient exposure to create beta burns, especially with extended exposure. Certain isotopes emit gamma radiation which penetrates any protective garment causing continued radiation exposure to the victim and health care workers. This contamination also must be removed.

(1) Management. Radiologically contaminated casualties must be decontaminated before admission to an MTF. Monitoring is conducted when potentially contaminated casualties arrive at the MTF. This monitoring is conducted at the MTF's receiving point/entry control point (ECP) before admitting the casualty. To properly handle radiologically contaminated casualties, medical personnel must first detect the contamination. Detectors that may be used to monitor casualties for contamination are the AN/PDR 77, AN/VDR 2, and ADM 300. Generally, a reading on the meter twice the current background reading indicates that the casualty is contaminated.

(2) Decontamination. Radioactive decontamination is simple; removing all outer clothing and a brief washing or brushing of exposed skin will reduce 99 percent of contamination; vigorous bathing or showering is unnecessary. Do not let radiological contamination interfere with immediate lifesaving treatment or the best possible medical care. See Chapter V for details on casualty decontamination.

(3) Treatment. Treatment procedures for radiation injuries are described in the *Emergency War Surgery* handbook, *Medical Management of Radiological Casualties Handbook*, and FM 4-02.283/NTRP 4-02.21/AFMAN 44-161(I)/MCRP 4-11.1B.

f. Management of Casualties Injured by Nuclear Weapons. Management of casualties injured by the immediate effects of nuclear weapons (flash, blast, and thermal) is the same as for conventional battlefield injuries, although the injury severity may be increased. First aid (self-aid, buddy aid, and combat lifesaver [CLS]) for lacerations, broken bones, and burns are performed. Combat lifesavers in the US Army are Soldiers that have been trained to conduct enhanced first aid. The following are types of injuries associated with nuclear warfare:

- Flash injury. The intense light of a nuclear fireball can cause flash blindness. The duration of blindness depends upon the length of exposure and the light conditions. However, even at night it is unlikely that flash blindness will last more than a few minutes. Most individuals can continue their mission after a short recovery period. Severe cases may have retinal and optic nerve injuries that lead to permanent blindness; these cases will require evacuation to an MTF.
- Blast injuries have three types of effects—
  - Primary injuries are due to overpressure that is, eardrum rupture, lung injury, and so forth.
  - Secondary blast injury is due to flying debris that is, penetrating injury due to shrapnel.
  - Tertiary blast injury is due to translational injury that is, the victim is blown into the air and suffers blunt trauma by deceleration.
- Thermal injury. Thermal injuries are generated by—
  - Direct thermal radiation (flash burns and eye injuries).
  - Indirect (flame) effects.

- Radiation injury. Casualties produced by ionizing radiation alone or with other injuries will be common. Due to the limitations inherent in field medical treatment and mass casualty care, it will not be possible to determine the total radiation exposure of most victims. Additionally, total exposure may not be received at one time, but as the result of several incidents in contaminated regions.

g. Handling and Management of Toxic Industrial Materials Casualties. Although the hazards of weaponized chemicals have long been recognized, the hazards of industrial materials have only recently become more widely understood. Deliberate terrorist release or inadvertent release of TIM significantly increases hazards to the indigenous population and deployed US forces. While CW agents are highly toxic and lethal in small amounts, the countries producing them are generally known and are few in number when compared with the quantities and universal nature of TIM.

(1) Toxic industrial materials include chemicals manufactured for use in industrial, commercial, or medical processes. Toxic industrial chemicals/TIMs can be in gas, liquid, or solid form (include particles), though those of particular concern tend to be gases because gas spreads easily. Some common TICs include: ammonia, chlorine, and hydrogen cyanide.

(2) Exposures to TIMs can result from accidental releases, collateral damage from explosions/attacks near stored chemicals, or intentional dispersion with explosives such as improvised explosive devices (IEDs). Insurgents in Iraq have used chlorine gas tanks packaged with IEDs. Toxic industrial materials of concern can be found almost anywhere, but primarily in: chemical plants, industrial manufacturing facilities, wastewater treatment plants, chemical/waste storage facilities/landfills, laboratory settings, large fuel storage areas, and at major transportation centers including the vehicles (for example, trains, barges).

(3) Health effects can vary and depend on the type of chemical/material, how it enters the body, the amount, and how long personnel were exposed. Some bodies may have unique reactions to certain TIMs and some may have no reaction at all. Potential symptoms of exposure include immediate or short-term (acute) health effects: coughing, difficulty breathing, and/or irritation of the nose, mouth, throat, eyes, or skin. Acute exposure to certain TIMs at high dosage(s) can cause death. For more information on diagnosis and treatment information refer to USACHPPM Technical Guide (TG) 273.

(4) While the acute toxicity and associated immediate severe health effects of TIMs are often the primary concern, exposures to certain TIMs can potentially cause long-term or permanent health effects. Industrial chemicals are often corrosive and can damage equipment to include electronic equipment. Many TIMs are flammable, explosive, or react violently with air or water and therefore present physical hazards which can be greater than the immediate toxic effects from an industrial chemical release.

(5) Operational Planning for Toxic Industrial Material Hazards:

(a) Crisis Action Planning. In concurrence with deliberate and crisis action planning, CCDRs, command surgeons, HSS planners, preventive medicine (PVNTMED) personnel, bioenvironmental engineers, and public health personnel should develop an understanding of the potential hazard from TIM in the AO. Information required to support vulnerability analysis and assessment during the planning process include some of the following key factors—

- Identifying all possible industrial plants, storage sites, and shipping depots.

- Identifying TIM routinely produced, used, or processed in the area. Knowledge of the manufacturing processes used at an industrial plant is especially important as TIMs are often used as intermediates in the production of plastics, pesticides, and herbicides or other products and materials.
- Assessing the effects of the release of TIM either as a result of collateral damage or an accident.
- Assessing whether the deliberate release of a TIM is realistic in a particular situation. Factors that should be considered in this assessment are—
  - Terrain and meteorological conditions.
  - Political environment (serves as a bargaining chip).
  - Military advantage or benefit to be gained.
  - Psychological impact.
  - Assessing the need for special detectors and/or modifications to detectors.
  - Assessing potential information items for the commander. These items include—
    - How does one determine if there is a potential threat?
    - Is there a special way one needs to react to these chemicals that is different from the way he has been trained?
    - Where is it safe to be?
    - How much exposure is safe?
    - What decontamination equipment can be used or is needed?
    - What are the short-term and long-term health effects?
    - What are the effects on noncombatants?
    - What are the effects on military equipment including individual protective equipment (IPE)?

(b) Hazard Level Zones Determination. Plans supporting determination of hazards levels (hot, warm, and cold zones) for each hazard site and immediate evacuation from the hazard's path are the best defense against the TIM hazard. Commanders should consult with the engineer officer, CBRN defense officer, legal officer, command surgeon, intelligence officer, PVNTMED staff, meteorologists, fire and security personnel, emergency response hazardous materials (HAZMATs) incidents team, civil military operations officer and public affairs officer (PAO) when identifying hazard levels (zones). These staff officers can provide guidance for hazard isolation, site entry control, decontamination, on-scene medical treatment, evacuation, civilian populace, and in-place protection.

(c) When evacuating the hazard area, individuals should wear clothing that prevents deposit of liquids and minimizes injury to exposed skin. Evacuees should not be permitted to congregate except at established safe distances. Evacuation to established safe distance does not guarantee complete safety for evacuated personnel. Evacuated personnel should be moved to a designated location by a specific route and to a distance where additional movement is not required following a radical wind shift. Refer to the Department of Transportation (DOT) *Emergency Response Guidebook* for hazardous materials incidents and information on hazard level zones. This guidebook can be obtained at <http://hazmat.dot.gov/pubs/erg/guidebook.htm>.

(6) Vulnerability Mitigation to Toxic Industrial Material Hazards.

(a) Each TIM incident has multiple considerations. When planning, ensure to obtain key information regarding effects, toxicity, production, storage facilities, and

transportation of TIM. This information can be acquired through companies that produce the TIMs, experts (for example, scientific or civilian industrial personnel, CW treaty experts), material safety data sheets, and local civilian authorities that have emergency response procedures and resources.

(b) Refer to the National Center for Medical Intelligence (NCMI), Air Force Institute for Operational Health, <http://www.brooks.af.mil/units/airforceinstituteforoperationalhealth/index.asp> and USACHPPM, <http://chppm-www.apgea.army.mil/> for additional information. Reachback information can be found in Appendix D.

---

Note: Military CBRN protection, detection, and decontamination equipment were not designed for handling TIM.

---

(c) In conducting detection procedures, some plants, facilities, storage containers, or transport containers may be identified by markers. These could take the form of international hazardous chemicals (HAZCHEMs) markers that are diamond-shaped (United Nations markers) and contain information that can be used to identify the exact industrial chemical. When encountering a suspect industrial chemical, attempt to identify the exact TIM and all possible information on the material. For proper handling, protection, and hazard-management information, responders seek guidance from their command and control (C2) element. Other sources for assistance include the Chemical Transportation Emergency Center hot line, for emergency assistance within the US/Canada: 1-800-424-9300 or outside the continental United States (OCONUS): 1-202-483-7617 (toll free). Commanders also identify the local civilian authorities that may have additional emergency response procedures and resources.

(d) Mission-oriented protective posture (MOPP) ensemble, CBRN detection equipment, and CBRN decontamination procedures are specifically designed for use and tested against CW agents. Toxic industrial materials present hazards that may render CBRN equipment and procedures ineffective. Each TIM should be evaluated individually to establish protection and response procedures and to select associated equipment requirements. The military protective mask may be used under emergency conditions to protect against the immediate toxic effects of some TIMs and while evacuating from the immediate hazard zone. However, the protective mask may or may not be effective in protecting against high concentrations of TIMs over an extended period of time. Commanders should consider the use of appropriate protective equipment such as self-contained breathing apparatus (SCBA), substance-specific cartridges or canisters, and change-out requirements tailored to the TIM threat at each location.

#### (7) Precautions and Decontamination in Toxic Industrial Material Environment.

(a) Personnel or equipment that may have been contaminated with TIM can usually be decontaminated by washing with large amounts of soapy water. Contaminated clothing should be immediately removed and disposed of in a safe manner; however, when no release has occurred, establish a minimum hazard level zone based on mission requirements, surveys, and assessments of the TIM facility.

(b) If a TIM release occurs, evacuate beyond the established hazard level zone. Reduce safety exclusion areas only after a detailed survey and assessment of the extent of the probable hazard area. When friendly units are required to operate in an area where a potential TIM facility exists, planners should—

- Coordinate with civilian or host nation emergency response teams.

- Identify the probable TIM, extent of possible contamination, minimum protective equipment, and personnel safety considerations.
- Coordinate with higher headquarters and the host nation to identify support availability.
- Develop an incident response plan. For detailed information and procedures for response plans, refer to Service-specific publications that provide templates for plan development (for example, FM 3-11.21/MCRP 3-37.2C/NTTP 3-11.24/AFTTP [I] 3-2.37; AFMAN 32-4004; and AFMAN 32-4013).
- Implement the TIM reconnaissance plan and assign units to prepare and execute the reconnaissance missions.
- Use commercial detectors which can provide confirmation of individual TIM, if available.
- Coordinate with decontamination elements for decontamination of personnel and equipment.
- Coordinate for transport and delivery of collected samples to the supporting laboratory.
- Avoid hazard areas as long as possible. When conducting reconnaissance or rescue operations near or within the hazard area, equip ground survey teams with respiratory protection (for example, SCBA) and skin protection certified for the TIM. Use aerial or visual reconnaissance to help collect information to support C2 operations.
- Coordinate with theater medical elements (for example, PVNTMED teams) for follow-on industrial hygiene assessments, as dictated by mission requirements.

(8) Toxic Industrial Material Information Management Resources.

(a) The DOT *Emergency Response Guidebook* lists HAZMATs commonly shipped in the US. This publication is primarily a guide to aid first responders in quickly identifying the specific or generic hazards of the materials involved in the incident and protecting themselves and the general public during the initial response phase of the incident.

(b) The National Institute for Occupational Safety and Health (NIOSH) Pocket Guide to Chemical Hazards (NPG) provides reference information in a table format, which can be used for hazard assessment and management. The information includes chemical names, synonyms, trade names, exposure limits, physical and chemical properties, chemical incompatibilities and reactivities, personal protection measures, and health hazards. The NPG can be obtained at <http://www.cdc.gov/niosh/npg/npg.html>.

(c) Field Manual 8-500 provides guidance on TIM hazards for first responders. This manual details basic procedures to be accomplished with existing medical protocols.

(d) The USACHPPM *Deployment Health Guide: Toxic Industrial Chemicals (TIC) Release Response* (<http://chppm-www.apgea.army.mil/documents/Disaster/TICResponse2.pdf>) identifies and defines TIC hazard categories and specific TICs of concern and provides information that can help reduce risk of injury or disease during continental United States (CONUS)/OCONUS military missions involving a hazardous or TIC release. This guide addresses a variety of audiences but is primarily aimed at PVNTMED assets who have key responsibilities to help ensure the health and safety of a unit.



(e) The USACHPPM Hazardous and Toxic Industrial Chemicals Tables; (<http://chppm-www.apgea.army.mil/chemicalagent/PDFFiles/TICRepsonseCharts.pdf>) provide chemical, physical, and health effect information for key TICs of military concern (includes acutely toxic airborne hazards, example chemicals that are physical hazards, and example chemicals that are acute ingestion hazards).

(f) The USACHPPM TG 273 provides some basic principals regarding TICs, toxidrome, health effect and treatment information for irritant gases, corrosives, organics, asphyxiants, and cholinergics.

(g) The USACHPPM TG 230 provides military exposure guidelines for chemicals in air, water, and soil for use during deployments. Specific information is provided regarding the type and severity of health effects resulting from exposures to varying chemical concentrations, the primary organs/systems affected, odor/taste threshold information, and additional notes when available. This TG provides application guidance describing how the military exposure guidelines can be used to characterize the level of health and mission risks associated with identified or anticipated exposures to chemicals in the deployment environment in a manner consistent with the existing military operational risk management paradigm.

(h) The USACHPPM Chlorine and Improvised Explosive Devices factsheet [http://usachppm.apgea.army.mil/documents/FACT/36-015-0407\\_Chlorine\\_IEDs.pdf](http://usachppm.apgea.army.mil/documents/FACT/36-015-0407_Chlorine_IEDs.pdf) is a PVNTMED reference tool and checklist for predeployment and response actions. The IED factsheet includes predeployment planning actions, chlorine physical and chemical characteristics, exposure signs and symptoms, protection against exposures, decontamination and treatment, response actions and considerations, and documentation requirements.

(i) The USACHPPM TG 244 addresses operational health concerns in environments where CBRN threats exist. Potential CBRN threats range from weapons of mass destruction (WMD) to contamination of the battlefield by hazardous material. Medical personnel, in conjunction with chemical personnel, must be able to advise commanders on a wide range of issues including the health effects of NBC threats, protective clothing and measures, and management of NBC casualties. This manual is not an emergency response book or treatment guide. It is intended to provide a quick reference for decisionmaking as to whether to request expert consultation in a given area.

#### **4. Military Operations in a Chemical, Biological, Radiological, and Nuclear Environment**

a. A number of potential adversaries have or are in the process of developing WMD. Some terrorist groups and several countries designated as *State Sponsors of Terrorism* have also shown an interest in pursuing a CBRN capability. Others are strongly engaged in the sale or transfer of associated CBRN technology. Chemical, biological, radiological, and nuclear weapons are considered *asymmetric threats*, since adversaries will seek an advantage over the US by using unconventional approaches to circumvent or undermine our strengths while exploiting our vulnerabilities. The potential for catastrophic use of WMD is greater than it has been in many decades. Aimed at responding to the overwhelming power and superiority of the military infrastructure of the US, either domestically or abroad, WMD could seriously disrupt the execution and tempo of military operations. It is imperative that FHP and HSS plans are prepared to reduce the effects that WMD has on the execution and tempo of military operations.

b. The medical commander must consider the nature of the environment. If the immediate environment is vulnerable to CBRN attack, the commander should determine the level of protection that would be needed, during, and after the attack. The mission of medical units in a CBRN environment is to survive the attack and sustain the supported force. In addition to providing medical care after the attack, the commander needs to know whether to expect residual contamination to remain and how long it is likely to persist. The commander needs to determine—

(1) Level of protection required. Is eye-respiratory protection sufficient or is full body coverage required?

(2) When to increase the protective posture. Donning protective clothing too soon can have an unwarranted negative impact on the Service member's ability to perform mission-related tasks. Donning it too late can result in casualties.

(3) Medical facility decontamination. Is facility decontamination required and, if so, which option is best?

(4) When to relax the protective posture. When is it safe to remove protective clothing to reduce heat stress and other restrictions on job performance? Is Split MOPP operation applicable to the situation?

(5) In addition to these considerations, the commander must consider other vulnerability reduction measures and be prepared to provide support to branches and sequels of the supported commander's operation. Refer to FM 3-11.14/MCRP 3-37.1A/NTTP 3-11.28/AFTTP (I) 3-2.54 for more information.

c. Stability Operations.

(1) The US Armed Forces participate in full spectrum operations in an effort to deter war, resolve conflict, promote peace, and support civil authorities in domestic and foreign emergencies as permitted by law. Stability operations may be conducted as a precursor to combat operations, in parallel with ongoing combat operations, or following the cessation of combat activity.

(2) State-supported and nonstate terrorist groups may employ CBRN weapons, or natural and man-made disasters may contaminate areas with toxic materials whose mitigation will require the efforts of specialized military forces. The conduct of stability and reconstruction operations in a CBRN environment may require coordination and cooperation with agencies, organizations, and individuals, outside the military chain of command or direct control. In many stability and reconstruction operations situations, the JFC may be in a supporting role to civil authorities or to host nation authorities. Regardless of the role, the JFC and joint force elements must be prepared for CBRN use and contamination with toxic materials at any point, including the transition from noncombat to combat environments. Additionally, Chairman of the Joint Chiefs of Staff Instruction (CJCSI) 3214.01 defines responsibilities for planning and conducting military consequence management (CM) operations in response to incidents on foreign soil involving WMD (FM 3-11.21/MCRP 3-37.2C/NTTP 3-11.24/AFTTP [I] 3-2.37).

(3) The HSS planning activities generally include hospitalization, PVNTMED, veterinary services, HSL, and medical regulating and patient movement. Plans for OCONUS and CONUS operations should include provision for surge medical requirements using on-hand and rapidly deployable capabilities. Special consideration is required for HSS to noncombatant evacuation operation evacuees who may have been exposed to CBRN or other toxic agents. In the US, there may be a requirement to augment civilian

medical capabilities in the handling of casualties resulting from CBRN attacks or other toxic material contamination. The ability of domestic and host nation medical facilities to handle mass casualties from CBRN effects should be assessed and factored into joint and multinational HSS planning.

(4) Close coordination with HSS personnel and other public health providers in the theater is a vital means of detecting BW and CW attacks, since casualties from such an attack may appear initially in the civilian medical system.

d. Health Service Support in Multinational Operations.

(1) Language, values, religious systems, economics, and social outlooks can have great impact on the delivery of FHP and HSS. Forces of member nations must be supported either by national assets or through the alliance/coalition assets. Because resource contributions will vary between nations, some may contribute logistically, while others contribute military forces. Commanders of multinational forces should seek to ensure that member forces are appropriately supplied consistent with their nation capabilities and the terms established at the formation of the alliance and/or coalition.

(2) Plans in multinational operations should be coordinated with member forces.

(3) Health service logistics is a major challenge for multinational operations. Planning issues to consider are—

(a) Health service logistics doctrine (JP 4-08).

(b) Stockage levels, logistics mobility, interoperability, infrastructure, national resource limitation, and host nation and alliance/coalition support limitations/agreements. Joint force commanders typically form multinational logistics staff sections early to facilitate coordination and support of operations.

(c) Operations abroad may involve military support to other countries' civil authorities. This support is controlled by the US ambassador/country team or provided directly by the JFC according to bilateral or multinational arrangements. In all circumstances, commanders must reduce the vulnerability to a CBRN attack and be prepared to mitigate and recover from the consequences of a CBRN attack. Joint force commanders and joint/multinational elements must be prepared for CBRN use and contamination with TIMs at any point. For further guidance regarding stability operations, refer to Department of Defense Directive (DODD) 3000.05.

e. Operations in Extreme Environments.

(1) Enemy employment of CBRN weapons or TIMs in the extremes of climate or terrain warrants additional consideration. These considerations include the peculiarities of urban terrain, mountains, snow and extreme cold, jungle, and desert operations in a CBRN environment with the resultant CBRN-related effects upon medical treatment and medical evacuation. For a more detailed discussion on CBRN aspects of urban terrain, mountain, snow and extreme cold, jungle, and desert operations, see FMs 3-06; 3-06.11; 90-3/Fleet Marine Force Manual (FMFM) 7-27; and 90-5.

(2) In mountain operations, passes and gorges may tend to channel the nuclear blast and the movement of BW and CW agents. Ridges and steep slopes may offer some shielding from thermal radiation effects. Close terrain may limit concentrations of troops and fewer targets may exist; therefore, a lower patient workload may be anticipated. However, the terrain will complicate medical evacuation operations and may require patients to be decontaminated, treated, and held for longer periods than would be required for other operational areas.

(3) The effects of extreme cold weather combined with CBRN-produced injuries have not been extensively studied. However, with traumatic injuries, cold hastens the progress of shock, providing a less favorable prognosis. Thermal effects will tend to be reinforced by reflection of thermal radiation from snow- and ice-covered areas. Care must be exercised when moving chemically contaminated patients into a warm shelter. A CW agent on the patient's clothing may not be apparent. As the clothing warms to room temperature, the CW agent will vaporize (off-gas), contaminating the shelter and exposing the occupants to potentially hazardous levels of the agent. A three-tent system is suggested for processing patients in extreme cold operations. The first tent (unheated) is used to strip off potentially contaminated clothing. The second tent (heated) is used to perform decontamination, perform emergency medical treatment (EMT), and detect off-gassing. The third tent (heated) is used to provide the follow-on care and patient holding.

(4) In rain forests and other jungle environments, the overhead canopy will, to some extent, shield personnel from thermal radiation. However, the canopy may ignite and create forest fires and result in burn injuries. By reducing sunlight, the canopy may increase the persistency effect of CW agents near ground level. The canopy also provides a favorable environment for BW agent dispersion and survival.

(5) In desert operations, troops may be widely dispersed, presenting less profitable targets. However, the lack of cover and concealment exposes troops to increased hazards. Smooth sand is a good reflector of nuclear thermal and blast effects; generating an increase in the number of injuries. High temperatures will increase the discomfort and debilitating effects on personnel wearing MOPP, especially heat injuries.

## **5. Health Service Support Planning Considerations**

a. Health service support is integral to theater strategic, deliberate, and crisis planning and execution. To provide adequate FHP and HSS, definitive planning and coordination with component/joint planning and intelligence staffs are required. The FHP and HSS activities must ensure adequate preparations before and during the transition to these operations in a joint environment. Additional guidance is provided in JP 3-0 and JP 4-02.

b. The CCDR establishes the command's FHP and HSS requirements and uses directive authority to ensure the proper coordination of all FHP and HSS capabilities in the force. Planning for HSS must include all aspects of HSS requirements especially the unique characteristics and effects of CBRN weapons and TIMs. Health service support planning must begin simultaneously with the operational planning process to ensure its synchronization with the campaign plan or operation plan (OPLAN). Timely, effective planning and coordination are essential for ensuring HSS mission success. The health threat, occupational and environmental health (OEH) threats, medical intelligence, patient estimates, theater evacuation policy, hospitalization, patient movement, and available lift, all play a significant part in supporting the theater mission. The medical planners must consider the above listed factors in planning FHP and HSS in support of the CCDR. Joint Publication 4-02 reflects more detail on FHP and HSS planning. Plans must include PVNTMED, bioenvironmental engineering/public health, and veterinary support as part of the early entry force to ensure DNBI prevention and food safety considerations begin as the force enters the theater of operations (TO). Refer to JP 5-0 for additional information on contingency and crisis action planning.

c. It is imperative that medical CBRN defense be fully integrated into the deliberate planning process to maximize readiness. Key elements include patient estimates, medical surveillance, OEH surveillance, prophylaxis (including immunizations), diagnostics, mass

casualty management, evacuation, and casualty decontamination requirements. The potential for high host nation casualties may make host nation medical facilities unavailable to the joint force. Gaps in the medical CBRN defense capabilities of multinational forces must be addressed in order to ensure multinational cohesion and effectiveness in both planning and operations. Joint and multinational exercises must include realistic standards for conducting HSS operations in a CBRN environment.

d. In addition, key staff elements must be closely coordinated with during the planning process. The CBRN staff will have conducted the CBRN intelligence preparation of the operational environment and development of CBRN aspects of courses of action (COAs). In addition CBRN, operations, and intelligence staffs will require input during the planning process in selection of decision points and trigger levels following biological attacks. Medical input is key in developing biological surveillance plans which aid in the rapid decisionmaking necessary to reduce the risk to the force. Additional information can be found in FM 3-11.86/MCWP 3.37.1C/NTTP 3-11.31/AFTTP (I) 3-2.52. Planning must also consider the use of all health service support capabilities to prevent, detect, respond, and recover from CBRN attack. Each capability has a role to play to mitigate the effects of an attack and each must be synchronized with both the medical and nonmedical capabilities.

e. The USAF theater medical system operates within the air and space expeditionary task force (ASETF) and joint task force (JTF) structures to support CCDR's objectives. When the threat of CBRN use is high, a robust expeditionary CBRN structure is required to support the mission. To assist operational planners and the Air Force forces (AFFOR) as they develop concept of operations (CONOPS) in support of JFC deliberate and crisis action plans, this section offers the following planning guidance for employment of Air Force Medical Service (AFMS) assets in CBRN environments. Planners must review and understand the mission capability statements and CONOPS of the various AFMSs unit type codes (UTCs) to fully understand how best to employ them.

f. Planning the flow of resources into the theater and the continued sustainment of those resources should involve input from the commander and his planning, operations, and logistics staffs to ensure campaign objectives are met with minimal overall operational risk. This must be considered during all phases of campaign planning and execution. Health service support planners should provide the commander a risk analysis and recommendations on COAs to support CBRN-related operations.

## **6. Command, Control, Communications, Computers, and Intelligence Systems in a Chemical, Biological, Radiological, and Nuclear Environment**

a. The JFC controls the C2 system to ensure that data and information get to the right place on time and in a form that is quickly usable by its intended recipients. In this regard, command, control, communications, computers, and intelligence (C4I) systems play a critical role in delivering this data throughout the joint force. These communications systems permit the JFC to pass critical information at decisive times, to exploit tactical success, and to facilitate future operations. Logistics, operations, and intelligence functions all depend on responsive C4I systems. The C4I systems are the central system tying together all aspects of joint operations and allowing commanders and their staffs to initiate, direct, monitor, question, and react.

b. In a CBRN environment an unbroken chain of communications must extend from the CCDRs, commanders of Service components, and all subordinate commanders. The C4I systems must provide this chain of rapid, reliable, and secure flow and processing of data to ensure continuous information exchange throughout the force. To ensure the continuous

and uninterrupted flow and processing of information, joint warfighters must have C4I systems that are interoperable, flexible, responsive, mobile, disciplined, survivable, and sustainable.

c. In a high threat CBRN environment, it is imperative that the communications architecture includes lines of communication among deployed combat units, medical units tasked with providing medical care, and specialized units providing CBRN detection, warning, and decontamination functions. To provide adequate defense, the Marine air-ground task force commander organizes CBRN defense assets. Units at all levels must be capable of detecting and identifying CBRN agents, warning of and reporting CBRN attacks, performing individual and collective protection measures, decontaminating personnel, equipment, and terrain, and administering first aid according to unit medical operations and exposure guidance. For more information on HSS C2 see FM 4-02 (Army), Air Force Doctrine Document (AFDD) 2 (USAF), MCWP 3-37.1 (USMC).

d. Operational Communications.

(1) The Annex K of the OPLAN details the communications architecture between echelons of command and between supported and supporting units and provides security procedures and frequencies. Refer to Appendix B for more information and sample of a medical annex. In cases where no OPLAN is published, the tasking order should provide communications details or is determined in predeployment planning between the medical commander and the supported command surgeon for medical communications and within the deploying medical forces for internal communications. It is critical to ensure that communications assets and systems are compatible with systems used in the TO.

(2) National policy dictates the survivability of C4I systems through which decisions are transmitted to the command forces. It is not practical or economically feasible to make all C4I systems or elements of a system equally survivable. The degree of survivability for C4I systems supporting the function of C2 should be commensurate with the survival potential of the associated command centers. (Refer to JP 6-0.)

## **7. Obtaining Medical Intelligence Information on Chemical, Biological, Radiological, and Nuclear Threats**

a. Operations in a CBRN environment place a great need for HSS demands on the intelligence system. A clear and commonly shared assessment of adversary CBRN capabilities and US, multinational, and host nations HSS capabilities and limitations in countering adversary CBRN use are of great importance. The CBRN threat information gathered by the component/joint intelligence staff is used by the deployed HSS staff for planning and the employment of HSS assets. Threat assessments should include the identification of industrial sites in the theater that use, produce or store large quantities of TICs. Toxic industrial materials could become a health hazard to deployed forces if these sites are accidentally or intentionally destroyed or left in normal operation. Threat information is also used to prepare the health threat and update environmental health and industrial facility databases. The NCMI produces all-source medical intelligence assessments for HSS functions.

b. The NCMI responds to requests from the Armed Forces for emergency, up-to-date medical intelligence assessments. The NCMI is the nation's premier producer and coordinator of all-source medical intelligence. The NCMI produces intelligence for global force protection and homeland health protection to safeguard US interests worldwide. The NCMI remains an integral part of the Defense Intelligence Agency (DIA).

c. The NCMI predecessor, the Armed Forces Medical Intelligence Center, focused on force protection for deploying DOD military personnel. The NCMI is integrating foreign intelligence and partnering with domestic agencies to share health information to protect the health and welfare of US military forces and citizens, at home and abroad. The NCMI's growing partnerships include the Department of Homeland Security and other domestic agencies, and coalition and foreign partners. The NCMI partners with other intelligence agencies to provide critical information on countries that do not report openly share health information with international health agencies such as the World Health Organization (WHO). For these countries, medical intelligence may be the only source of information on health threats.

d. Some of the functions of NCMI are to—

- Assess potential health threats to foreign populations and medical capabilities to respond to these threats in support of US health diplomacy missions in developing countries.
- Assess foreign intelligence on veterinary disease threats and capabilities to assist in decisions on preventing and controlling these diseases overseas before they impact the homeland.
- Monitor the threat of global outbreaks of diseases such as anthrax and of terrorist or criminal use of TICs.

e. The NCMI partners with other intelligence community and nonintelligence community agencies within the federal government and with US allies to provide intelligence in three critical ways—

(1) Provide earliest possible warning on foreign health threats to prevent serious illness and/or mitigate potential impacts.

- Identify, assess, and prepare reports on naturally occurring outbreaks of diseases such as an avian influenza, anthrax, plague, or West Nile virus.
- Evaluate a wide range of TICs to identify potential environmental hazards and model health impacts.
- Assess health events such as disease outbreaks and chemical releases to identify and warn on possible indicators of terrorism and/or intentional use of biological or chemical agents.

(2) Develop and disseminate intelligence reports and forecasts on the following health threats and issues:

- Foreign health systems' capabilities to support and sustain forces in the field, and medical response capabilities to naturally occurring bio-threats and CBRN events.
- Foreign environmental health risks, including TICs.
- Foreign infectious disease threats, including baseline intelligence on the natural distribution of known BW agents such as anthrax and plague.
- Foreign applications of biotechnology such as vaccines and therapeutics for avian influenza and CBRN medical defense.

(3) The NCMI fosters information-sharing partnerships with academia, industry, other federal agencies, and foreign nations.

- The NCMI leads intelligence community outreach efforts on health threats and issues to collaborate and consult with academia and industry to understand such diverse topics as newly emerging dangerous pathogens,

modeling of the dispersion of chemical hazards, and trends in development of future medical therapeutics and vaccines.

- The NCMI collaborates with federal agencies to share health information and analytic methodologies to bolster the capabilities of the US government to warn of foreign and domestic health threats and to model possible intervention scenarios to assist decisions on countermeasures to prevent serious illness and/or mitigate health impacts.

f. Accurate and timely medical intelligence is a critical HSS tool for planning, executing, and sustaining all military operations. A supporting intelligence element should exist at some point in the medical unit's chain of command. This element, whether military or civilian, should be the primary source for the HSS planner to access the necessary intelligence for the execution of HSS operations. The HSS personnel must develop a feedback system with the supporting intelligence element to provide and receive intelligence updates.

g. When obtaining intelligence to meet specific medical requirements, first determine if local intelligence data or NCMI publications can satisfy requirements. If significant requirements remain unanswered then submit a formal request for information through intelligence channels. The request will be reviewed by the component/joint intelligence officer, Joint Staff Operations Directorate (JSOD) (J-3), or up or down to the level where the desired information is available. These requests could conceivably be passed up to the primary source of the DOD strategic intelligence, the DIA. In this case, DIA may validate the requirements and submit them to the NCMI for completion. The requirements become tasks for NCMI to respond to the requester.

h. Accurate and timely medical intelligence is a critical HSS tool for planning, executing, and sustaining all military operations. A supporting intelligence element should exist at some point in the medical unit's chain of command. This element, whether military or civilian, should be the primary source for the HSS planner to access the necessary intelligence for the execution of HSS operations. The HSS personnel must develop a feedback system with the supporting intelligence element to provide and receive intelligence updates.

i. There are other specialized organizations that provide expert information resources on medical aspects of CBRN threats, casualty prevention, CBRN agent sample and specimen collection, and medical care and management of casualties. These include the Defense Threat Reduction Agency (DTRA), the Armed Forces Radiobiology Research Institute (AFRRI), the Naval Medical Research Center (NMRC), the US Army Medical Research Institute of Infectious Diseases (USAMRIID), the US Army Medical Research Institute of Chemical Defense (USAMRICD), USACHPPM, and the US Army Nuclear and Chemical Agency (USANCA). See Appendix D for more information on technical reachback points of contact.

j. United States Air Force HSS in a CBRN environment reflects the Air Force ground support operational environment. Air bases are lucrative targets for attack. The USAF deployed medical facilities may be located near active airfields that are likely targets for military or terrorist CBRN attack. The AFMS assets support the passive defense component of USAF operational counter CBRN doctrine (refer to AFDD 2-1.8), as well as the tactical surveillance and identification components of the crosscutting element of command, control, communications, computers, intelligence, surveillance, and reconnaissance (C4ISR).



(1) Medical assets and information can save lives and maximize combat effectiveness by providing critical components of the air base “passive defense,” conducting tactical CBRN surveillance and identification missions, and by properly treating, stabilizing, and processing CBRN casualties.

(2) The deployed medical commander (DMC) has a need-to-know and must be cognizant of operational intelligence pertaining to the CBRN threat. The DMC and key staff must have appropriate security clearances for access to this information. The DMC and his key CBRN staff must be integrated into the ASETF battle staff and CBRN cell, as tactically and situationally appropriate.

## **8. Joint Warning and Reporting Network**

a. The Marine Corps is the lead Service for implementation of the Joint Warning and Reporting Network (JWARN) program. The JWARN will provide joint forces with an integrated comprehensive analysis and response capability to minimize the effects of hostile CBRN attacks or accident/incidents, environmental hazards, or hazards from TIM. The system will consist of hardware, software, and connectivity with command, control, communications, computers, intelligence, and information (C4I2) systems and remote detectors/sensors. The JWARN will be compatible and integrated with Joint/Service C4I2 systems, the Defense Medical Surveillance System (DMSS), and networks/broadcasts.

b. The JWARN is an acquisition category (ACAT) III (Sentinel and Oversight Program) information system that networks CBRN sensors, mission application software tools, and C4ISR systems. The JWARN builds on Block I capabilities by fully integrating with common operating environment-based and tactical C4ISR systems automatically generates alerts for warning and dewatering affected forces automatically generates hazard area plots.

c. The JWARN provides the JFC with the capability to—

- Report CBRN and TIM hazard detection.
- Analyze the detections to enable identification of the hazard and the affected locations and units.
- Disseminate warning information to affected units in near real time.
- Control and configure a local sensor network.
- Generate and display hazard areas Interconnected to weather and medical databases.
- Retrieve and archive automatically event data to enable postoperations forensic evaluation.

d. The JWARN Block 1 (JWARN 1E/Signal Fire) enables an immediate and integrated response to threats of contamination through rapid warning and dissemination of CBRN information—

- Collect and consolidate sensor information manually.
- Report CBRN and TIM hazard detection.
- Generate hazard area plot Allied Tactical Publication (ATP)-45(C), hazard prediction and assessment capability (HPAC), and joint effects model (JEM).
- Display hazard warning area on common operational picture (COP) networked to C2 personal computer and Maneuver Control System.
- Generate warning and dewatering (CBRN) messages to affected forces.

e. The JWARN provides benefits to the warfighter—

- Automates the current largely manual, error-prone process.

- Minimizes time from detection to warning (less than 2 minutes).
- Provides timely warning and dewatering of affected units to maximize combat effectiveness.
- Automates recording and archiving of exposure data which will enable more effective forensic analysis.
- Integrates with current and future C4I2 systems.

f. The JWARN is designed to—

- Integrate and be compatible with Joint Service C4I2 systems located in C2 centers at the appropriate level, defined by Service specific annexes, and employed by CBRN defense specialists and other designated personnel.
- Disseminate warnings and transfer data for decisions down to the lowest level on the battlefield.
- Provide additional data processing, production of plans and reports, and access to specific CBRN information to improve the efficiency of limited CBRN defense personnel assets.
- Accelerate the warfighter's response to an enemy CBRN attack.

g. Medical units and staffs must be integrated into the COP provided by JWARN. The information contained in the system includes NBC-1 through 5 reports as well as NBC situation reports (SITREPs). These reports quickly allow the medical staffs and units to gain situational awareness to anticipate the locations, timing, and magnitude of required medical asset support requirements. Additionally, NBC reports (NBC-4 or NBC SITREP) may be submitted by medical units or staffs upon diagnosis of a disease or injury of interest such as anthrax or chlorine exposure, both of which may occur clandestinely with the first indication being presentation at an MTF.

## Chapter II CASUALTY PREVENTION

### 1. General

a. Casualty prevention, a force multiplier, is essential throughout the health life cycle of Service members. Before deployment, good health requires control of environmental (to include disease and stress) and occupational threats to prevent casualties and to maintain a healthy and fit force. During deployment, the enemy and the total environment present a health threat to the forces. The enemy threat produces most combat-related casualties commonly called battle injuries, while disease, environmental injuries (such as heat and cold), and stress threats produce DNBI casualties. Implementation of casualty prevention management limits casualties from environmental, occupational, operational, and CBRN warfare threats.

b. Casualty prevention is a CBRN passive defense force multiplier focusing on threats posed by enemy forces and complex endemic and environmental health threats. Failure to counter these threats jeopardizes mission accomplishment. Casualty prevention concentrates on countering two types of threats: health threat and enemy threat. The health threat is composed of a complex set of environmental and operational factors that combine to produce DNBI which, historically, creates the largest number of military casualties. The enemy threat usually produces smaller numbers of more seriously injured casualties. The enemy threat depends on the enemy's willingness and ability to use conventional and nonconventional weapons systems, munitions, and CBRN agents. Failure to counter either threat jeopardizes mission accomplishment and ultimately impacts achieving operational objectives. Medical readiness provides the means to mitigate these threats. Information provided by ongoing health surveillance and DNBI reporting is critical to counter CBRN operations and are used as passive defenses and medical surveillance for casualty prevention.

c. Passive defense protects personnel from the effects of a CBRN attack and improves the capability of personnel to survive and sustain operations in a CBRN environment. Passive defense includes FHP and HSS measures, a process that begins before deployment, and encompasses the entire deployment scenario. The elements of passive defense measures against a CBRN attack consist of: contamination avoidance, protection, and contamination control. For more information on passive defense, see FM 3-11 (FM 3-100)/MCWP 3-37.1/NWP 3-11/AFTTP (I) 3-2.42 and FM 3-11.34/MCWP 3-37.5/NTTP 3-11.23/AFTTP(I) 3-2.33. Preparations for operations in potential CBRN environments begin early in predeployment and include threat assessments, medical screening, preexposure immunizations, pretreatments, prophylaxis, quantitative fit testing and risk-based training on the ability to survive and operate (ATSO) in CBRN environments, training for HSS personnel in the use of protective equipment, and training of medical personnel in the specifics of CBRN casualty care.

d. Casualty prevention seeks to provide the line commander the best available health-based risk assessment of the tactical situation improving his situational awareness and enabling the warfighter to perform the mission. It becomes imperative that passive defenses be aggressively pursued and institutionalized throughout the deployment process. By using chemoprophylaxis early on, as indicated through health surveillance, we can secure and sustain an effective force.

e. Prevention of DNBI casualties requires the full commitment of individual Service members and unit commanders. Health service support actions required to prevent and/or mitigate DNBI include—

- Implementing and refining medical and OEH surveillance activities.
- Collecting and analyzing specimens and samples.
- Developing objective exposure measurements to identify DNBI threats.
- Determining effective methods of assessment.
- Developing countermeasures to mitigate actual and potential health threats.

f. Geographic dispersion of forces and improved personal protective systems will reduce injuries.

g. Prevention of CBRN casualties requires full use of detection capabilities, timely reporting, and use of protective measures.

## **2. Medical Surveillance and Occupational and Environmental Health Surveillance Activities**

a. Medical surveillance is the ongoing, systematic collection, analysis, and interpretation of data derived from instances of medical care or medical evaluation, and the reporting of population-based information for characterizing and countering threats to a population's health, well-being, and performance.

b. Occupational and environmental health surveillance is the regular or repeated collection, analysis, archiving, interpretation, and dissemination of OEH-related data for monitoring the health of, or potential health hazard impact on, a population and individual personnel, and for intervening in a timely manner to prevent, treat, or control the occurrence of disease or injury when determined necessary. For more information on medical surveillance and OEH surveillance, see DODD 6490.02E, Department of Defense Instruction (DODI) 6490.03, and Memorandum for the Chairman (MCM) -0028-07.

c. The determination of unit-specific rates of illness and injuries (including related CBRN/TIM casualties) of public health significance is the foundation of these programs. Surveillance is closely integrated with the timely dissemination of data to those responsible for the prevention and control of DNBI. Implementing guidance is found in DODI 6490.03. The establishment of uniform and standardized health surveillance and readiness procedures for all deployments is contained in DODD 6490.02E, and DODI 6055.1.

d. Surveillance forms a basis for medical resource allocation, refines knowledge of the health threat, and permits continual assessment of the effectiveness of measures used to prevent and control DNBI. The surveillance teams gather, analyze, and submit this information to commanders, command surgeons, medical planners, and others that require this information.

## **3. Medical Countermeasures for Chemical, Biological, Radiological, and Nuclear Casualty Prevention**

a. Combatant commanders must ensure PVNTMED supplies and equipment are provided and maintained to support implementation of their prevention responsibilities. Additionally, they should maximize the use of joint training to exploit existing Tri-Service PVNTMED expertise. Preventive medicine training is essential for DNBI prevention and should become an integral part of predeployment preparation.

b. The spectrum of FHP and HSS capabilities must include the ability to prevent and mitigate the effects of CBRN casualties and conventional injuries. Health service support includes a combination of preventive and curative measures that are effective in a CBRN environment. Therefore, commanders must ensure that all personnel are in a constant state of readiness to survive and accomplish their missions in CBRN environments. In addition to ensuring that immunizations are kept current, commanders must ensure that personnel are fully trained in the techniques and procedures for CBRN survival. This includes regularly scheduled training and instruction in the use of all available IPE and available medications (such as chemoprophylaxis, pretreatments, and barrier creams).

c. Endemic disease and BW agent threats in the joint operational area (JOA) must be identified during the predeployment period. It is important to monitor the health of the force to gauge the predeployment health status of units and to identify preexisting (baseline) health characteristics of an individual. Infectious diseases in the AO should be prioritized and monitored according to the threat each poses to the force and the achievement of the mission. Appropriate medical countermeasures must be implemented, particularly in the areas of food and water vulnerability, waste disposal, and personal protective measures (such as immunizations, prophylaxis, insect repellents, and insect netting).

d. Preventive measures in FHP and HSS planning for CBRN environments include—

(1) Development of the body's natural defenses through individual and unit health and fitness programs.

(2) Integration of military PVNTMED and civilian public health preventive capabilities to the extent feasible.

(3) Protection of medical supplies and equipment by using CW agent-resistant coatings and covers.

(4) Frequent testing of all food and water sources and supplies for CBRN contamination.

(5) Force protection measures extended to HSS organizations and facilities to ensure HSS availability in the event of adversary CBRN attacks.

(6) Integration of HSS units and facilities into joint force plans and activities to limit CBRN exposure and contamination following a CBRN attack, through application of CBRN defense principles.

e. During deployment, vigilant monitoring of DNBI rates (sick call, outpatient treatment, and hospital admissions) in relation to the numbers of disease vectors and local pathogens is required for effective planning and refinement of appropriate countermeasures to infectious disease. Information drawn from historical data, type of deployment, duration of the deployment, and the level of support needed can be used to create a predictive DNBI model.

#### **4. Disease Incidence Following the Use of Chemical, Biological, Radiological and Nuclear Weapons**

a. Factors of prime importance in determining the nature and severity of the disease effects are—

- Immunization status of personnel.
- Underlying health status of the population.
- Population density.

- Degree of industrialization in the AO.
- Availability of health services.
- Availability of sanitation facilities.
- Availability of food supplies.
- Availability of water and ice.
- Climate.

b. The manner and situation in which nuclear weapons are used is important. A single weapon detonated in a socially stable area will have less serious effects than a detonation in an area where combat has already disrupted the social stability. At Hiroshima and Nagasaki, Japan (excellent examples of the first type of situation), the survivors who could get away were able to obtain food, shelter, and care from surrounding intact areas. With prolonged combat operations, such intact areas would not be available, resulting in no food, shelter, or care for survivors. There will be a breakdown in social order and there will be a lack of effective medical support (including PVNTMED functions and facilities).

c. Without PVNTMED capabilities, increased incidence and morbidity from diseases will follow. Some diseases will predominate in incidence, depending upon the geographical areas involved and the endemic diseases present.

(1) In urban areas with temperate climates, several diseases are epidemic threats. These epidemic threats may include—

- Dysentery (due to a variety of pathogens).
- Rickettsial diseases, particularly typhus and scrub typhus.
- Hepatitis.
- Tuberculosis.
- Malaria and cholera (in many parts of the world).

(2) There are several reasons for the increased risk of disease including, but not limited to—

- Crowding of surviving populations with limited sanitary facilities as was seen during the flight of Rwandan refugees into the North Kivu region of Zaire and in Europe at the end of World War II.
- A lack of prophylaxis and immunizations with resultant increases in the susceptibility factor of a given population.
- A lack of pest management activities.
- With the high levels of fallout covering wide areas, a large number of people will sustain sublethal whole-body doses of radiation. The interaction of irradiation with infections is not clear; but it may be the result of latent infections manifesting and decreased resistance to infection. The result is an increased incidence of disease.
- Each class and order of animals has marked differences in sensitivity to irradiation. Arthropods, for example, are much more resistant than vertebrates. The normal balance between arthropods and birds that prey upon them in a given area may be severely upset, producing a marked overgrowth of arthropods. If the arthropods include vectors of disease there would be a serious increase in disease hazards. If there is an increase in arthropods that destroy vegetation there would be a serious destruction of food crops.
- The introduction of a BW agent in an AO in which the disease organism is endemic or epidemic can increase the risk level for exposed personnel.

d. This risk can be mitigated by the rapid diagnosis of BW infection. Medical units including PVNTMED, veterinary detachments and field hospitals now have the capability to identify BW agents in specimens and samples. The Joint Biological Agent Identification and Diagnostic System (JBAIDS) uses polymerase chain reaction (PCR) to identify the deoxyribonucleic acid (DNA) of threat agents. For more information on JBAIDS, refer to Chapter VII.

e. Routine disease surveillance information may be the sentinel indication of BW agent use. Early disease recognition enables effective intervention. A BW attack may create a disease mass casualty situation in the area of operation. The medical commanders have the core knowledge and competency for many BW passive defense actions. The medical commander fields deployable and forward-deployed assets that employ biotechnology to rapidly and accurately identify specific pathogens of military concern. This capability, coupled with health surveillance systems built on advanced information technology and management architecture can provide early recognition of a covert BW attack and rapid identification of agents, vastly improving commander situational awareness and enabling early and appropriate intervention.

## **5. Sustainment of Health Service Support Operations in a Chemical, Biological, Radiological, and Nuclear Environment**

a. Planning for and maintaining a sound medical and OEH surveillance program for all operations can maximize force effectiveness by eliminating or reducing the effects of CBRN threats. Health service support personnel must include the unique characteristics and effects of CBRN weapons/agents in their FHP and HSS plans. Although most essential care is rendered outside the area of immediate combat in a nontactical environment, triage, patient decontamination, and initial resuscitative care are necessary in the combat area. Medical commanders must ensure that MTFs can locate clean areas to establish operations or employ collective protection shelter (CPS) systems in areas that have the potential for being contaminated.

b. The CCDR and his medical planners establish the command's HSS requirements and ensure the proper coordination of all HSS capabilities. Medical plans must account for the possible disruption of supply lines, contamination or destruction of medical units, and the contamination of medical evacuation assets. Resupply of units in the downwind hazard area or on the far side of a contaminated area must account for the need to protect both the Class VIII supplies, the platform used to conduct the resupply, and the personnel conducting resupply. Prior coordination for thorough or operational decon must be made with the CBRN staff. Medical Chemical Defense Materiel (MCDM) will be in demand post CBRN attack. The MCDM must be pushed to locations near to the units attacked to allow resupply of nerve agent antidotes, antibiotics, or skin decon kits to both Service members as well as for medical equipment set (MES) potency and dated (P&D) items. The CBRN casualty estimation during the planning process will give medical planners and logisticians an approximate demand for MCDM following a CBRN attack. Casualty estimation both aids in risk assessment, course of action analysis, and medical force planning.

c. Adversary use of CBRN weapons/agents can cause large numbers of casualties in a short period of time. In addition to agent-related casualties, planning should include a means to manage/triage nonagent harmed personnel/psychological casualties who may overwhelm medical/triage or other health monitoring assets in an event involving CBRN agents. This has been borne out in real life incidents such as the Tokyo subway sarin gas release and the radiological accident in Goiania, Brazil; where the number of nonagent harmed persons reporting to be monitored/addressed through health assessment far exceed

actual medical casualties (the Goiania incident nonagent casualties outnumbered those actually exposed to radiation 450:1). Commanders and HSS planners must have procedures in place for CBRN casualty management. Effective care and management of CBRN casualties require planning to treat large numbers of individuals as discussed in Chapter III.

d. Planners must include a comprehensive, workable plan to decontaminate casualties to be evacuated from the TO. Contaminated casualties must be decontaminated before entering the strategic air evacuation system unless the CCDR and Commander, United States Transportation Command (USTRANSCOM) direct otherwise.

e. When BW agents are a threat, decontamination, isolation, and processing procedures must be in place to prevent the spread of contagious infections. Every attempt should be made to contain contagious diseases within the AO. Adequate preplanning is particularly critical when contagious casualties (for example, smallpox or plague) are anticipated. Preplanning coordination with USTRANSCOM on the use of air assets, and the Department of State (DOS) for permission to fly contagious casualties over another nation's airspace, must be accomplished. Refer to Chapter IV of this manual; FM 8-284/NTRP 4-02.23 (NAVMED P-5042)/AFMAN (I) 44-156/MCRP 4-11.1C; AFTTP 3-42.3; and AFTTP 3-42.5 for more detailed information. The most current guidelines can be obtained from the Commander, USTRANSCOM.

f. The demand for PVNTMED and US Public Health Service (PHS) will increase commensurate with the CBRN threat. Preventive medicine and public health personnel and the command surgeon assist the CCDR in determining the health risks associated with CBRN hazards, the safety of drinking water and ice, and the appropriate time for using pretreatments, prophylaxis, immunizations, barrier creams, and other preventive medicine measure (PMM). Preventive medicine and public health personnel must establish and maintain medical and OEH surveillance programs. These programs are established before deployment and continue after deployment. To maintain combat effectiveness, commanders and HSS personnel must continually evaluate capabilities and make adjustments to conform to the CCDR's priorities.

## **6. Preparation and Training for Chemical, Biological, Radiological, and Nuclear Defense**

a. Health service support encompasses a full spectrum of operational medical concepts designed to establish future benchmarks for the military health system (MHS) challenges delineated in Joint Vision 2020. Health service support is more than clinical medicine; it involves enhanced methods of preventing casualties before, during, and after a military operation. The tenets of FHP and HSS include—

- (1) Emphasis on fitness, preparedness, and preventive measures.
- (2) Improvements in monitoring and surveillance of threats and forces engaged in military operations.
- (3) Service members' and commanders' awareness of the health threat before it can affect the force.

b. Medical readiness training is founded on the art of military medicine. The training includes an understanding of how the combat environment (including CBRN) affects—

- Service members and the related preventive and clinical interventions required.
- Hazard exposures and regional diseases.



- Baseline clinical competence, including mass casualty management.
  - Clinical knowledge and skills specific to combat-unique injuries, CBRN injuries, and familiarity with platform-specific roles, supplies, and equipment.
  - In addition to the training clinical skills in casualty management medical care providers must be trained to survive in a CBRN environment.
  - Medical planners must be trained to plan for operations in a CBRN environment.
  - Collective training must include appropriate CBRN scenarios.
- c. For more information on the efficiency and interoperability of medical support planning for operations in CBRN environments refer to STANAG 2478.

## 7. Predeployment Procedures

a. Predeployment requires inclusion of detailed planning for FHP and HSS in a CBRN environment. Health service support commanders and planners must look beyond mobilization. They must be prepared to deploy their command at a short notice to a CBRN environment and conduct their mission both in CONUS and OCONUS. They must project the unit's theater requirements and provide the required support. In preparing for deployment, unit commanders should consider but not be limited to—

(1) Requesting information on the CBRN threat in the AO. Confirming all personnel have up-to-date prescribed immunizations for CBRN threats and are physically fit for deployment.

(2) Ensuring each person receives force health protection prescription products (FHPPP) such as DOD-prescribed CBRN immunizations, prophylaxis, barrier creams, and pretreatments.

(3) Ensuring personnel treat uniforms with approved insect repellent systems.

(4) Incorporating CBRN-related PMM into the standing operating procedure (SOP).

(5) Ensuring personnel have adequate personal hygiene supplies.

(6) Ensuring personnel have their chemical protective overgarment, gloves, overboots, protective mask, skin decontaminating kits (SDKs), and individual equipment decontamination kits.

(7) Distributing PVNTMED guidelines.

(8) Establishing a medical surveillance system.

(9) Establishing an OEH program.

(10) Ensuring units have authorized CPS systems and that personnel are trained on their employment.

(11) Conducting just-in-time (JIT) training on CBRN subjects according to the projected operating environment.

(12) Ensuring commanders, as well as all deployable personnel, are trained in Service-specific operational risk management methods.

b. Logistics requirements and sustainment operations are a critical concern to the battlefield commander throughout the campaign. Deploying units must be self-sustaining for a specified period of time after arrival within the theater. Pre-positioned logistics may augment the supplies and equipment that accompany deploying units.

c. Mobility strategy demands that forces are able to move personnel and materiel to the scene of a crisis at a pace and in numbers sufficient to achieve quick, decisive mission success. Air and sea lift users must supply a full and complete description of all air and sea lift requirements in order for the USN and USAF to match transport assets against those requirements. This is accomplished through the time-phased force and deployment data (TPFDD) validation process. Medical planners must ensure CPS systems and medical CBRN defense equipment are correctly reflected in the TPFDD. The TPFDD is the supported CCDR's statement of his requirements by unit type, time period, and priority for arrival used in the joint mobility strategy. The TPFDD is both a force requirements document and a prioritized transportation movement document. The TPFDD also defines the CCDR's nonunit-related cargo and personnel requirements to include civilians to sustain his forces.

## 8. Predeployment Actions

a. The capability to defend against CBRN attacks and sustain combat operations in CBRN environments requires forewarning and properly trained and equipped forces throughout the theater. Casualty prevention initiatives using passive defense measures are planned for early in the predeployment planning process. Passive defense measures include consideration of the four Ss: Sense, Shape, Shield, and Sustain. *Sense* is action to detect CBRN attack and include syndromic surveillance, clinical diagnosis, occupational and environmental health surveillance and other medical indications and warnings. *Shape* is the ability to form a medical or integrated CBRN COP and include CBRN casualty estimation, health risk assessment, and medical asset and workload visibility. *Shield* is the ability to protect personnel through vaccinations, pretreatments, collective and individual protection, health risk education, and medical restriction and quarantine. *Sustain* is the ability to recover and conserve the fighting strength through patient decontamination, treatment, provision of psychological support, risk communication, and the application of medical individual decon kits to include M291 Skin Decon Kits or reactive skin decon lotion (RSDL) as well and medical unit operational and thorough decontamination.

b. The medical commander must ensure that the following actions are addressed during the predeployment phase. For more information on predeployment health activities, refer to DODI 6490.03.

(1) Medical Estimate of Situation. The HSS planner officer or noncommissioned officer (NCO) or the designated medical intelligence officer, in conjunction with the medical CBRN defense officer and the CBRN casualty management officer, will do the medical estimate. Medical commanders will conduct predeployment vulnerability assessment of PVNTMED concerns (validating NCMI-identified health threats). Assess vulnerabilities to local food and water sources, potential epidemiological threats, local medical capabilities, vector/pest threats, and hygiene of local billeting and public facilities. These assessments will provide the necessary information to determine the initial force protection strategies and resources required to mitigate risks to DOD personnel and assets.

(2) Casualty Prevention Measures (Shield). These actions must be done prior to deployment:

(a) Immunizations:

- Department of Defense minimum requirements must be current (as defined by the most recent Advisory Committee on Immunization Practice vaccine-specific schedules) in tetanus-diphtheria, influenza, hepatitis A, measles, mumps and rubella, and polio.

- Service-specific requirements. Refer to Army Regulation (AR) 40-562/ Bureau of Medicine and Surgery Instruction (BUMEDINST) 6230.15A/Air Force Joint Instruction (AFJI) 48-110/Commandant, US Coast Guard Instruction (CG COMDTINST) M6230.4F.

(b) Deployment-specific medical countermeasures. Based upon the geographical location, the CCDR will determine the need for—

- Additional immunizations (for example, anthrax, meningococcus, or Japanese encephalitis vaccine, smallpox).
- Chemoprophylactic medications (for example, mefloquine, chloroquine, doxycycline).
- Other individual personal protective measures (such as insect repellent, insect netting, and uniform impregnation).

(c) Individual health assessment. Conduct predeployment health assessments using the Department of Defense (DD) Form 2795 (Pre-Deployment Health Assessment) and ensure medical and dental requirements are current according to Service policy, including—

- Mandatory occupational health examination and training requirements (for example, respirator exams and fit testing).
- Dental Class I/II (refer to FM 4-02.19).
- Significant health conditions (for example, medical profiles, pregnancy).
- Collection of additional baseline biological samples as warranted by the deployment health threat.
- Human immunodeficiency virus (HIV) testing according to Service policy or the supported combatant commander policy (serves dual purpose: HIV screening and predeployment serum sample).
- The most recent tuberculin skin test (TST) results must be documented appropriately in the deployment health record. Currency (or periodicity) of TST is established by Service-specific policies based upon analysis of Service-unique risk factors. Thus, Service policies may permit more than a 24-month period to elapse between TSTs. (For previous purified protein derivative converters handle according to Service policy.)
- Deoxyribonucleic acid sample on file. To confirm the unit/individual status of DNA specimens on file, contact the DOD DNA Specimen Repository (commercial telephone [301] 295-4379, facsimile [301] 295-4380, or e-mail [afrssir@afip.osd.mil](mailto:afrssir@afip.osd.mil)).
- Ninety to 180-day supply of prescription medications.
- Required medical equipment (such as glasses, protective mask inserts, hearing aids, or dental orthodontic equipment, and so forth).
- Medical Record. Create or update the deployed medical record (DD Form 2766 [Adult Preventive and Chronic Care Flowsheet]) with—
  - Blood type.
  - Medications/allergies.
  - Special duty qualifications.
  - Corrective lens prescription.
  - Immunization record.

- Completed DD Form 2795. Medical summary sheet identifying medical conditions (such as glucose-6-phosphate dehydrogenase [G6PD] deficiency, sickle cell trait, and so forth).

(d) Predeployment health threat brief. Provide information to deploying personnel identifying health threats and countermeasures to include applicable immunizations and other preexposure drugs such as pyridostigmine bromide.

(e) Medical CBRN defense briefing. Train all personnel in CBRN-related self-aid, buddy care, and CLS skills to include immediate decontamination and the administration of nerve agent antidotes, and the wear/care and inspection of protective mask and clothing. Train all medical personnel in CBRN casualty triage and treatment. Train WMD personnel in triage, emergency treatment in a CBRN environment, and how to thoroughly decontaminate CBRN-contaminated casualties.

(3) Review of medical plans. All medical predeployment/deployment pertinent to providing operational support (such as CCDR OPLANs, OPLAN Annex I, deliberate plans from the beddown base, and CBRN passive defense plans) must be reviewed. This plan will define how the medical force will arrive at the deployment location, set up, and achieve initial operational capability (IOC) status.

(4) Coordinate service and support. Medical, civil engineering (CE), transportation and logistics support personnel must work together to provide the base with a fully integrated CBRN defense capability. The medical commander coordinates with CE readiness support when integrating CBRN considerations into the beddown plan to prevent duplication of effort. The medical commander and his staff coordinate with the logistics planner to prioritize time-phased flow of medical materiel and personnel to accommodate the most appropriate time to have resources and CBRN passive defense capabilities in theater.

(5) Conducting risk assessments for all known health hazards in accordance with JP 3-0., JP 2-01.3, and Service operational risk management guidance. Incorporate health risk assessments into overall operational plans and specify requirements for risk control decisions by the appropriate level in the command.

(6) Incorporating risk management and surveillance recommendations into the FHP and HSS Appendix, Annex I (Medical) of the deliberate or crisis action plan.

## **9. Deployment Procedures**

a. During deployment, commanders maintain vigilance to ensure CBRN preparedness of their units that includes JIT training and individual and unit protective equipment inspections. Refining the existing medical contingency response plan to reflect the current mission, identification of CBRN threats and other factors will impact the health of the force operating in a CBRN environment. Commanders must ensure—

(1) Up-to-date medical surveillance/documentation and OEH surveillance data in accordance with applicable policies.

(2) Review of casualty prevention responsibilities, review of casualty care responsibilities, review of decontamination capabilities and water supply for decontamination and the review of resupply issues to include adequate supplies of antidotes, anticonvulsants, bandages, mask filters, IPE for HSS staff and anticipated casualties, and patient protective wrap (PPW) for anticipated casualties.

(3) Personnel must—

- Use work/rest cycles during the early stages of the deployment to become acclimated to the AO (to include the ability to operate in MOPP Level 4), mission permitting.
- Take prophylaxis and pretreatments as prescribed.
- Keep immunizations up to date.
- Use barrier creams (skin exposure reduction paste against chemical warfare agents [SERPACWA]) when assuming MOPP Level 4.
- Use the insect repellent system.
- Practice good personal hygiene.
- Drink adequate amounts of water.
- Request PVNTMED support when needed.
- Practice good field sanitation processes or measures.

b. The supported CCDR will provide guidance and support to component commands to—

(1) Develop individual protection and unit deployment policy for deploying personnel to include which MCDM should be issued to individuals or to units in bulk.

(2) Develop policy on the storage and handling of bulk issued MCDM to ensure the material remains effective throughout the operation. Each type of MCDM has unique storage requirements needed to prolong its efficacy; however, storage considerations must not outweigh the requirement for Service members to have the material available when needed.

(3) Ensure subordinate medical activities conduct timely, standardized, comprehensive surveillance, risk assessments, and prevention of health hazards.

(4) Ensure DOD health surveillance requirements are met for reporting and archiving of health surveillance data and reports (DNBI, reportable medical events, and OEH surveillance data). Ensure documentation in the individual medical records of all individual health treatment provided at all Roles of care and any notable environmental and occupational exposures. Special attention is needed to ensure individual exposure records can be linked to individual health records.

(5) Ensure environmental health risk assessments are continuously reviewed and updated throughout the deployment using data collected in theater. Significant newly identified risks should be communicated to all appropriate organizations, including the DIA through NCMI, combatant commands, Services, and Service occupational and environmental health centers.

(6) The JTF/combatant command personnel readiness unit will ensure the Defense Manpower Data Center is provided theater-wide rosters of all deployed personnel, their unit assignments (company-sized or equivalent) and the unit's geographic locations according to the reporting requirements of DODI 1336.5. Accurate personnel deployment rosters are required to assess the relative significance of medical disease/injury in terms of the rate of occurrence among the deployed population. Without the means to identify the locations of deployed personnel it will not be possible to accurately determine potential exposures to HAZMAT and agents.

(7) Conduct pest control operations using the integrated pest management program described in DODI 4150.07, DOD Pest Management Program. Document the types,

concentrations, amounts, application methods, dates and times, locations, and the personnel potentially exposed to the hazardous substances. The DD Form 2766 is the DOD standard form in the medical record for recording essential readiness indicators. This will be the common location for minimum documentation by all Services, which may be supplemented by other forms such as PHS Form 731 and Service-specific forms. The DD Form 2766 will deploy with the individual.

## 10. Deployment Actions

a. The deployment phase consists of preattack, attack, and postattack postures. The medical commander should be knowledgeable with the various capabilities of supporting medical units that are assigned and available to the deployed location, as well as the reachback capability of medical assets assigned to support the theater. The medical commander should use all resources available to provide protective measures for all assigned personnel and casualties. Detailed information on all phases of CBRN operations is found in FM 3-11 (FM 3-100)/MCWP 3-37.1/NWP 3-11/AFTTP (I) 3-2.42 and AFTTP 3-42.3.

b. Preattack phase casualty prevention measures—

- Site selection.
- Health surveillance and DNBI reporting.
- Vulnerability assessments and surveillance plans.
- In-processing deployment Service members.
- Field hygiene and sanitation.
- Collective protection.
- Individual protective equipment.
- Medical sector CBRN detection and contamination control plan.
- Establishment of decontamination operations and HAZMAT waste areas.
- Coordination of logistics for adequate resupply of PPW (to include blower unit), replacement mask filters, IPE, antidotes, anticonvulsants, and water supplies for medical decontamination.
- Continued training of medical and WMD personnel in CBRN casualty management.
- Preparation of hardened facilities depending on the threat condition.
- Coordination with CBRN staff for biological surveillance plan.
- Planning for sufficient patient movement item (PMI [ventilators]).
- Use of chemical agent detectors in patient treatment areas for unexpected chemical casualties.

---

Note: Must use blower unit when using PPW.

---

c. Attack phase casualty prevention measures include—

- Alarm conditions.
- Donning of IPE.
- Understanding MOPP level.
- Operation of CPS.
- Knowing ATSO principles for an environment.
- Monitoring of CBRN JWARN.

d. Postattack phase casualty prevention measures include—

- Surveillance for health risks and exposure symptoms requiring treatment.
- Detection of agents.
- Identification to determine the specific CBRN agent employed.
- Contamination avoidance.
- Continued protection measures.
- Contamination control/decontamination of personnel, equipment, supplies, and food stores as indicated.
- Triage/treatment of CBRN and conventional casualties.
- Coordination of casualty disposition/evacuation.
- Disposition of contaminated equipment and supplies.
- Patient quarantine.

## **11. Actions Before a Chemical, Biological, Radiological, and Nuclear Attack**

a. Given the disruption of transportation, communications, and operations during and following a CBRN attack, it should be clear that preparation is the key to survival and effectively providing HSS. Preparing a simple and complete tactical standing operating procedure (TSOP) and FHP and HSS plan that integrates CBRN is the first step. Critical training for medical personnel before a CBRN attack includes how to—

- Survive the attack individually and as a unit.
- Operate the Role 1 or Role 2 MTF in the environment.
- Effectively care for CBRN patients.

b. Even minimal site preparation (nuclear hardening or chemical-biological [CB] protecting) may improve survival, greatly reduce contamination, and maintain the ability to continue to provide HSS. The following discussion provides more information on each environment. As with other military personnel, HSS personnel must keep their immunizations current; use available prophylaxis against suspect CB agents; use pretreatments for suspect CW agents; use insect repellents; and have antidotes and essential medical supplies readily available for known or suspected CBRN effects. The best defense for HSS personnel is to protect themselves, their patients, and medical supplies and equipment by applying contamination avoidance procedures. They must ensure that stored medical supplies and equipment are in protected areas or in their storage containers with covers in place. One method of having supplies and equipment protected is to keep them in their shipping containers until needed. When time permits and warnings are received that a CBRN attack is imminent or that a downwind hazard exists, HSS personnel should employ their CPS (see Chapter XI) or seek protected areas (buildings, tents, or other aboveground shelters for BW or CW attack; culverts, ravines, basements, or other shielded areas for nuclear attack) for themselves and their patients. Other tasks include—

- Verifying CBRN defense FHP and HSS inventories are complete.
- Reviewing supported units CBRN plans, procedures, casualty collection points, decontamination sites, and resources available to support the HSS mission.
- Coordinating with the intelligence staff officer (S-2)/Army or Marine Corps component intelligence staff officer (Army division or higher staff, Marine Corps brigade or higher staff) (G-2)/intelligence directorate of a joint staff (J-2); operations staff officer (S-3)/Army or Marine Corps component operations staff officer (Army division or higher staff, Marine Corps brigade or higher staff) (G-3)/operations directorate of a joint staff (J-3); logistics staff officer (S-4)/Assistant

Chief of Staff for Logistics (G-4)/logistics directorate of a joint staff (J-4) of the supported unit to develop the HSS COAs to obtain necessary materiel to support extended operations without resupply (main supply route [MSR] contamination or transportation support is not available).

- Coordinating with supported units for at least eight nonmedical augmentation personnel to accomplish patient decontamination under medical supervision at the Roles 1 and 2 MTFs. The USAF only coordinates for personnel support only when not supported by an expeditionary medical decontamination team (EMDT). The EMDTs will generally support a 10-bed or larger USAF Expeditionary Medical Support (EMEDS) MTF in a CBRN environment.

## **12. Actions During a Chemical, Biological, Radiological, and Nuclear Attack**

a. While it is possible that the CBRN attack will be a discrete short event, the more likely scenario is the enemy will use CBRN throughout the conflict. The CBRN warning and reporting system (CBRNWRS) will provide as much notice as is possible. Using the information provided, HSS personnel will continue their mission by using the best available protected areas. If warned of a CBRN attack, personnel should take up positions within the best available shelter; and leadership will direct movement out of these positions when it is safe. For more information on CBRNWRS, see FM 3-11.3/MCRP 3-37.2A/NTTP 3-11.25/AFTTP(I) 3-2.56.

b. Redeployment procedures involve the transfer of units, individuals, or supplies from one AO to—

- Another AO.
- Other locations within the area.
- Their home station/demobilization station for the purpose of further operational employment.
- Demobilization.

c. Forces redeploy out of the operational area as quickly as mission, enemy, terrain and weather, troops and support available-time available, civil considerations (METT-TC) allow upon the achievement of objectives. However, the CCDR may have follow-on operations or security concerns that require a well-planned sequence to the drawdown of forces. The CCDR may order reconstitution operations to be completed prior to the redeployment of all forces. The tactical commander must plan redeployment consistent with the follow-on operational mission requirements. For more information on redeployment, see JP 3-0 and JP 5-0.

d. Careful contingency planning that provides workable guidelines for the disposition of casualties and remains must be conducted prior to the operation and prior to rotating troops out of the AO. If BW agents have been used in the TO, redeployment planning must include the health screening of troops before their movement out of the theater to prevent the spread of disease. Planning must also incorporate close coordination with multinational unit commanders, who have forces in the theater to ensure disease containment.

e. There are four phases to redeployment—

- Recovery, reconstitution, and redeployment planning activities.
- Movement to and activities at ports of embarkation.
- Movements to and activities at ports of debarkation.
- Reception, staging, onward movement, and integration (RSO&I).



f. Although many of the considerations for redeployment correspond to those for a deployment, there are differences. During deployment, elements of a unit are configured for strategic movement with the ultimate goal of reassembling the elements into an effective force in theater. During redeployment, unless the unit is redeploying to a new theater, the goal is to move forces home rather than building a force for theater operations. Therefore, redeployment preparation involves reestablishing unit integrity and accountability of personnel and equipment. In the reconstitution process, commanders reestablish the unit by undoing organizational changes made to the unit for operations in the theater. The unit may or may not redeploy to home station as a pure unit. Redeployment to new theaters may require organizational modifications, as in the original deployment.

g. The CCDR must consider actions to attain specific CBRN-related objectives and conditions particularly those associated with disabling or destroying enemy CBRN capabilities. The CCDR must also ensure all personnel and equipment is decontaminated before redeployment. Upon given notice from the CCDR, establishes when HSS requirements and capabilities are drawn down or are no longer needed.

### **13. Actions After a Chemical, Biological, Radiological, and Nuclear Attack**

a. After a CBRN attack, personnel should assess their own health status and those of their subordinates. All personnel must survey their equipment to determine the extent of damage and their capabilities to continue the mission. Initially, patients from nuclear detonations will be suffering thermal burns or blast injuries. Also, expect patients and HSS personnel to be disoriented. Nuclear blast and thermal injuries will immediately manifest; most radiation-induced injuries will not be observed for several hours-to-days; however, rudimentary assessment of radiation doses can be done by observing patient symptoms (for example, time until onset of vomiting). Chemical warfare agent patients will manifest their injuries immediately upon exposure to the agent, except for blister agents. Biological warfare agent patients may not show any signs of illness for hours to days after exposure, except for trichothecene mycotoxins. All patients arriving at Roles 1 and 2 MTFs must be checked for CBRN contamination. Unit chemical defense equipment including Automatic Chemical Agent Detector Alarm (ACADA), improved chemical agent monitor (ICAM), AN/PDR-77 and AN/VDR-2 radiation, detection, indication, and computation (RADIAC) set can be used for this purpose. In situations involving the rapid evacuation of casualties prior to identification of CBRN contamination, these systems can be used as monitoring devices in patient reception areas as they can be set to alarm when detecting contamination.

b. Patients are decontaminated before treatment (see Chapter V) to reduce the hazard to HSS personnel, unless life- or limb-threatening conditions exist. Patients requiring treatment before decontamination are treated in the EMT area of the patient decontamination site (PDS). Examples of patient conditions that may require treatment at the contaminated treatment station of the PDS are massive hemorrhage, respiratory distress, and/or severe shock.

c. Incident reports (including acute and/or catastrophic exposures to TIC/TIM and CBRN warfare agents) with accompanying data must be accomplished—

- Initial reports must be made not later than 7 days after an incident or outbreak.
- Interim and final reports shall be forwarded not later than 7 days after investigation and report completion.
- Combatant commands will forward copies of the reports to the (Defense Occupational and Environmental Health Surveillance (DOEHS) data portal for archival.

## **14. Other Chemical, Biological, Radiological, and Nuclear Defenses**

a. It is advisable to assign PVNTMED and/or veterinary representatives to monitor the breakout, preparation, and handling of food supplies in a contaminated environment. They should also be involved in the monitoring of potable water supplies for contamination.

b. In a biological hazard environment, medical personnel are responsible for evaluating biomedical samples for use in identification of the agent.

c. In radiological defense, medical personnel are responsible for recording the accumulated radiological dose of each Service member, treating casualties from radiation illness, and monitoring personnel who appear to have absorbed, inhaled, or ingested radiological contamination.

d. Personnel may be given potassium iodide pills (as a pretreatment) if the fallout from nuclear reactors is a threat.

## **15. Postdeployment Actions**

a. The postdeployment actions consist of a continual monitoring for medical and OEH surveillance and active collection of repository data. Actions will include—

- Completion of DD Form 2796 (Post-Deployment Health Assessment [PDHA]) for exposures documentation.
- All environmental exposures should be highlighted and surveillance data stored in the DOEHS Data Portal. Data must be sent and archived according to DODI 6490.03.
- Provider's responsibilities to redeploying personnel by continuation of medical treatment and documentation of casualties.
- Forwarding surveillance data to DOD as specified in DODI 6490.03.
- Disposition of contaminated equipment and supplies. Clean up of CBRN waste from patient decontamination sites will need to be addressed during decontamination operations and at their termination.
- Submission of FHP and HSS lessons learned in accordance with Service requirements and the Joint Uniform Lessons Learned System.

b. Service members are identified in need of medical evaluation upon return to home/processing station based on review of medical treatment received in theater, the post-deployment health assessment form, and other pertinent health surveillance data. Reserve Component (RC) members in need of a more detailed medical evaluation or treatment shall complete DD Form 2697 (Report of Medical Assessment) and, with the Service member's consent, be retained on active duty pending resolution of his medical conditions as provided in Section 12301 of Title 10, United States Code.

c. Medical debriefings are conducted with redeploying Service members on all significant health events, CBRN and TIM exposures, and concerns (also identified on postdeployment health assessments). Ensure these events and exposures are documented in individual Service member's health records. Medical debriefing ideally occurs within 5 days prior to departure from theater, but may be conducted within 5 days upon return to CONUS/home station.

d. Significant OEH-related events/exposures are included in operational after action reports (AARs). This will include any disease outbreaks, location of TIMs sources, contaminated sites (HAZMAT/wastes, CBRN, and other), presence of disease vectors, and other operational factors that affected the overall health status (acute, chronic, or latent

effects) of the deployed Service members. Ensure AARs are provided to the intelligence community (including NCMI) and Service centers for lessons learned to be incorporated into future operational planning.

e. The Armed Forces Health Surveillance Center (AFHSC) operates the DMSS deployment health data repository. All deployment health surveillance information will be forwarded to the DMSS for permanent archival and integration with DOD health information systems. For more information on postdeployment health assessment, see DODI 6490.03. Tri-Service reportable events guidelines and case definitions, blank pre- and postdeployment health assessment forms, DNBI reporting forms, and DMSS contact information are located on the AFHSC Web site at: <http://afhsc.army.mil>.

f. Health service support commanders must accomplish the following at the home station or processing station of the redeploying Service member—

(1) For deployments to high tuberculosis (TB) threat areas or operations, such as those involving close contact with large refugee populations, conduct TB screening between 3 and 12 months after redeployment according to Service-specific requirements. For deployments to low endemic TB threat areas, conduct TB screening according to Service-specific policy. Interpretation of the TST results should be according to Service policy.

(2) Collect, when indicated by Service policy, a serum sample for HIV testing and storage in the serum repository. Collect additional biological samples as warranted by the events occurring in theater or postdeployment health assessment responses and evaluations.

(3) Conduct additional health assessments and/or health debriefings when indicated.

(4) Service members returning from a theater with deployment-related health concerns will be evaluated using the Postdeployment Health Clinical Practice Guideline. Health care providers should consult the DOD postdeployment health Web site, <http://www.pdhealth.mil>, for further information on the clinical practice guidelines.

g. For postdeployment health reassessment, complete DD Form 2900 (Post-Deployment Health Reassessment [PDHRA]) when required. A DD Form 2900 will be administered to each redeployed individual within 90 to 180 days after return to home station from a deployment that required completion of a postdeployment health assessment. For individuals who received wounds or injuries that required hospitalization or extended treatment before returning to home station, the reassessment will be administered 90 to 180 days following their return home. After the DD Form 2900 is completed, a trained health care provider will discuss health concerns indicated on the form and determine if referrals are required. Educate individuals on postdeployment health readjustment issues and provide information on resources available for assistance. The original of the completed DD Form 2900 must be placed in the deployed individual's permanent medical record. Submit copies of the completed DD Forms 2900 electronically to the DMSS. Services may require submission of the forms to DMSS via their surveillance hubs.

**This page intentionally left blank.**

## Chapter III

# CASUALTY CARE AND MANAGEMENT

### 1. General

Operational casualty management strategies include effective care and efficient management by HSS organizations. Organizations should be prepared to treat large numbers of casualties in the event of CBRN weapon use. Casualties may include combatants and noncombatants. Large numbers of individuals with psychological stress reactions should also be expected. Each element of the medical evacuation and treatment process must balance casualty care issues with the goal of conserving and restoring the command's combat capabilities.

### 2. Chemical, Biological, Radiological, and Nuclear Mass Casualty

a. Mass casualty is any large number of casualties produced in a relatively short period of time, usually as the result of a single incident such as a military aircraft accident, hurricane, flood, earthquake, or armed attack that exceeds local logistic support capabilities. (Refer to JP 1-02 and FM 1-02/MCRP 5-12A).

b. With the employment of CBRN weapons/agents, a mass casualty situation can present itself at any time and at any role of care. Treatment is often limited to life- or limb-saving care and triage must be conducted within strict guidelines. It is important that all patients be decontaminated before they are admitted into an uncontaminated area.

c. The roles of military units and organizations need to be defined for a successful preparation, planning, and execution of decontamination operations.

(1) Individual responsibility. When a Service member becomes contaminated from a CBRN attack, the following immediate decontamination procedures are carried out to prevent him from becoming a casualty:

- Skin decontamination is a basic survival skill and should be performed immediately by the individual or a buddy upon being contaminated.
- Personal wipe down should be performed as soon as possible (preferably within 15 minutes of contamination). This is done to remove contamination from individual equipment. Use detector paper or an ICAM to locate the agent. Use a RADIAC set to locate radiological contamination and then brush, wipe, or shake it off.

(a) Self-aid. Self-aid consists of measures that Service members can apply in helping themselves. These include self-administration of antidotes (only for nerve agent exposure) and assumption of the appropriate MOPP level.

(b) Buddy aid. Buddy aid consists of emergency actions to restore or maintain vital body functions in a casualty who cannot administer self-aid. Mental confusion, muscular incoordination, physical collapse, unconsciousness, and cessation of breathing may occur so rapidly that the individual is incapable of providing self-aid. These actions include—

- Decontaminating the casualty.
- Putting the remaining protective clothing on the casualty to preclude further absorption of contamination through any exposed skin.
- Evacuating the casualty as soon as possible.

(2) Contaminated unit responsibilities include—

(a) Operational and thorough troop/personnel decontamination is carried out by contaminated units (with possible assistance from a decontamination unit). This may include individual decontamination beyond the scope of immediate decontamination, decontamination of mission-essential equipment, and limited terrain decontamination. Operational and thorough decontamination reduces the level of contamination, thus lessening the chance of spread and transfer. When combined with weathering, MOPP levels may be reduced without further decontamination, depending on the surface or material being decontaminated and the agent. See FM 3-11.3/MCRP 3-37.2A/NTTP 3-11.25/AFTTP(I) 3-2.56 for more information on the decontamination of specific surfaces.

(b) The contaminated unit is responsible for setting up, operating, manning, and closing the detailed equipment decontamination (DED), detailed aircraft decontamination (DAD), and detailed troop decontamination (DTD) area at the operational and thorough decontamination site.

(c) The higher headquarters of the contaminated unit (battalion, brigade, division, or corps) will coordinate and provide nonmedical personnel *augmentees* to support the medical unit/facility with patient decontamination. The USAF only coordinates with their higher headquarters for support only when not supported by an EMDT. The EMDTs will generally support a 10-bed or larger USAF EMEDS MTF in a CBRN environment.

(3) Chemical decontamination unit responsibilities include—

(a) Chemical, biological, radiological, and nuclear units (battalion crew, decontamination platoon) assist the contaminated unit with operational and thorough troop/personnel decontamination. The CBRN unit determines the general location of the DTD within the decontamination site and provides technical advice on setting up, operating, and closing the DTD area. The supported unit is required to keep on-hand supplies to conduct a DTD; however, the CBRN unit may supply the majority of the equipment and supplies expended to conduct a DTD. The CBRN unit will be responsible for submitting a complete CBRN 5 report after the site is closed.

(b) A supporting CBRN unit performs the DED or DAD. The DED and DAD operations are conducted as part of a reconstitution effort during breaks in combat operations. These operations require immense logistical support and are manpower-intensive. The DED and DAD restore items so that they can be used without protective equipment. As a safety measure, some Services require the use of protective gloves until clearance decontamination has been completed. These operations require support from a CBRN decontamination unit or element.

(4) Mortuary affairs responsibilities include—

(a) Mortuary affairs personnel are responsible for coordinating the disposition of contaminated remains. This includes the decontamination of remains when required. The joint mortuary affairs office acts as the theater central point of contact for coordination for the mortuary affairs decontamination collection point (MADCP). Refer to JP 4-06 for more information on the handling of contaminated human remains (HR).

(b) The CCDRs are responsible for searching for, recovering, tentatively identifying, and evacuating remains from their areas of responsibility (AORs).

(c) Service component commanders are responsible for providing or arranging for mortuary affairs support for their personnel.

(d) Subordinate commanders at all levels are responsible for the initial search for, recovery, tentative identification, and evacuation of all deceased unit personnel within their AO (see FM 4-20.64 and JP 4-06). If the threat of CBRN is suspected or present, commanders will request MADCP support to perform recovery operations and the subsequent decontamination of remains.

(e) The remains are placed in a CB HR pouch, if available, and care is taken to minimize the spread of contamination. When a CB pouch is not available, the Type II-A HR pouch should be used.

(f) Mortuary affairs decontamination collection point responsibilities include—

- Establishing and operating the MADCP and adhering to the procedures such as managing wastewater from decontamination operations and ensuring adequate rest cycles are in place as outlined in JP 4-06.
- Coordinating to pick up contaminated remains from PDS, MTFs, and troop DTD location for transport to MADCP.

(g) Personnel support is required after completing the evacuation mission to the MADCP, such as thorough DTD. The conduct of detailed HR decontamination takes about one hour per individual remains. The MADCP site will also receive support from a supporting decontamination unit for a complete DTD or for decontamination of HR.

(h) When remains arrive at the MADCP without the DD Form 1380 (US Field Medical Card [FMC]) or if it has not been reviewed and signed by a medical officer, the MADCP will coordinate with the supporting medical company or the nearest MTF as discussed in JP 4-06. The Armed Forces Medical Examiner (AFME) usually signs the DD Form 2064 (Certificate of Death [Overseas]); however, current procedure in theater requires the medical officer to sign the *draft* DD Form 2064 pending the AFME determination. The AFME is currently located at Dover AFB instead of in theater.

---

Note: Transportation and handling of remains is a logistics function.

---

(5) Medical unit responsibilities include—

(a) Medical personnel supervise the patient decontamination operations. For those MTFs not supported by an EMDT, augmentees from the supported units are usually required to assist in the decontamination process and perform patient lifting and washing. When a CBRN incident is expected, higher headquarters must plan, prepare, and coordinate to augment the medical units with nonmedical personnel in support of patient decontamination operation. Some basic information to consider when planning medical CBRN support—

- Each Service has patient decontamination procedures, including personnel and equipment requirements.
- Larger facilities, such as Roles 3 and 4, have more equipment and staff to handle larger numbers of patients evacuated to them from smaller, forward MTFs.
- No MTF is staffed to perform patient operational or thorough decontamination while providing medical treatment.
- Patient treatment, patient evacuation and protecting its medical staff from exposure to CBRN are the core mission of the medical personnel during a CBRN incident.

- Larger MTFs will require greater numbers of personnel as they will need to process greater numbers of patients.
- Roles 1 and 2 medical units capable of conducting split-based operations may collocate with CBRN decontamination units prior to an expected CBRN attack. This allows the use of experienced CBRN defense personnel to augment patient decontamination operations prior to the arrival of units conducting operational or thorough decontamination.
- In the US Army, the minimum number of personnel required for basic PDS operation at a Roles 1 and 2 MTF is 8 nonmedical personnel and 20 nonmedical personnel at a Roles 3 and 4 facility.

(b) Additional personnel should be considered to allow for a work-rest rotation of workers. These personnel are split into two categories to assist with either ambulatory and litter decontamination.

(c) Medically trained personnel are located at the triage area, dirty side EMT areas, litter and ambulatory decontamination areas, clean side of the hot line, and clean treatment area.

(d) Patient decontamination must be performed by nonmedical personnel from the supported units or units located within the base cluster or in vicinity of the MTF under the supervision of the medical personnel (see Table III-1).

(e) Assigned medical units/personnel support the contaminated unit during operational and thorough troop/personnel decontamination or DTD by providing medical support to the site (see Table III-2).

**Table III-1. Troop Decontamination Levels and Responsible Unit**

<i>Levels</i>	<i>Techniques</i>	<i>Responsible</i>
<b>Immediate</b>	Skin decontamination	Individual
	Personal wipe down	Individual/buddy
	Operator wipe down	Individual/crew
	Spot decontamination	Individual/crew
<b>Operational</b>	MOPP gear exchange	Unit
	Vehicle wash down	Battalion crew or decontamination platoon
<b>Thorough</b>	DTD	Contaminated unit with assistance from CBRN unit
	DED/DAD	Decontamination platoon
<b>Clearance</b>	Unrestricted use of resources	Supporting strategic resources



**Table III-2. Patient Decontamination Levels and Responsible Element**

<b>Levels</b>	<b>Techniques</b>	<b>Responsible</b>
<b>Immediate (Patient)</b>	Complete decontamination of contaminated areas of patient's MOPP prior to evacuation or RTD, without removing MOPP.	Individual/Buddy
<b>Operational/ Thorough (Patient)</b>	Decontamination at a PDS and treatment of conventional and chemical injuries at MTF prior to transport using ground, water, and air.	Augmentees supervised by medical unit/personnel

(6) The placement of the DTD or PDS depends upon METT-TC. The best scenario is to collocate medical patient decontamination and nonmedical troop decontamination side-by-side or in close proximity from each other for easy coordination. The PDS is for CBRN casualties requiring medical treatment while the DTD is for CBRN casualties requiring decontamination. Once it is determined that a CBRN casualty does not require medical treatment at the PDS, this casualty is sent to the DTD and not through the PDS for decontamination. Patient thorough decontamination involves decontamination procedures for litter and ambulatory patients. This encompasses a series of specific steps for patient medical stabilization, the removal of clothing, wash down, and mask removal before entry into the MTF. There is no room or the time to take care of nonmedical casualties at the PDS.

(7) The brigade level or equivalent is the lowest level that the DTD operation can be effectively planned. However, decontamination support for other unique operational organizations (for example, special operations forces) may require execution at a lower level. The operation requires close coordination between the chemical officer, logistics officer, command surgeon, and medical commander. The US Army field decontamination equipment sets provide buckets, sponges, liquid soap, high test hypochlorite (HTH) for a shuffle pit and hypochlorite solution preparation, litters, and litter stands. Decontamination procedures are generally personnel- and labor-intensive operations.

(8) Afloat Casualty Treatment/Patient Decontamination. As with shore forces, casualty decontamination should be performed separately from noncasualty decontamination. A medical staging area or mass casualty area should be placed near the decontamination area, but far enough away so that personnel will not be affected by any contaminant.

### **3. Triage**

a. Triage is the classification of patients according to the type and seriousness of illness or injury. It must be remembered that triage refers to priority for medical or surgical care, not priority for decontamination. Triage achieves the most orderly, timely, and efficient use of HSS resources. However, the triage process and classification of CBRN patients differs from conventional injuries.

b. In CBRN mass casualty situations, the magnitude of the casualty situation will necessitate that the conventional treatment priorities must be modified. This means a radical departure from the traditional practice of providing early complete essential treatment to each casualty on the basis of individual needs. For this concept of treatment, using priorities designed to assist in providing the greatest benefit for the largest number of patients without wasting specialist skill and medical resources, the following system of triage is used (ID-ME):

(1) **IMMEDIATE TREATMENT:** To include those requiring emergency life- or limb-saving surgery. These procedures should not be time-consuming and should concern only those casualties with high chances of survival. (Examples: respiratory obstruction, accessible hemorrhage, and emergency amputation.)

(2) **DELAYED TREATMENT:** To include those badly in need of time-consuming major surgery/resuscitation, but whose general condition permits delay in surgery/treatment without unduly endangering life. (Examples: Large muscle wounds; fractures of major bones; intraabdominal and/or thoracic, head, or spinal injuries; uncomplicated major burns; and some incapacitating effects of CBRN agents.) To mitigate the effects of often critical delay in surgery/treatment, sustaining treatment (such as stabilizing intravenous (IV) fluids; splinting; administration of antibiotics; catheterizations; gastric decompression; relief of pain; and pharmacological and respiratory support for the effects of CBRN agents) is required.

(3) **MINIMAL TREATMENT:** To include those with relatively minor injuries who can effectively care for themselves or who can be helped by untrained personnel. (Examples: Minor lacerations, abrasions, fractures of small bones, minor burns, and nonincapacitating effects of CBRN agents)

(4) **EXPECTANT TREATMENT:** To include casualties who have received serious and often multiple injuries, and whose treatment would be time-consuming and complicated with a low chance of survival. (Examples: Severe multiple injuries; severe head or spinal injuries; large doses of radiation; widespread severe burns; and intractable CNS respiratory effects of CBRN agents.) If fully treated, they make heavy demands on medical manpower and supplies. Until the mass casualty situation is under control, they will receive supportive care as allowed by manpower and resources available. Continued efforts to ensure their comfort by use of appropriate doses of narcotic analgesics and retriage as more resources become available is vital to manage these patients. The extent of treatment will depend on available supplies and manpower and may involve the use of large doses of narcotic analgesics. These casualties should not be abandoned, and every effort should be devoted to their comfort. The possibility of survival should always be kept in mind, even with alarming injuries. For more information on triage in a CBRN environment, refer to *Emergency War Surgery* (Third United States Revision) and *The Textbook of Military Medicine, Medical Aspects of Chemical and Biological Warfare* (Borden Institute).

c. Special categories of patients who do not easily fit into the above categories and casualties who pose a risk to other casualties, medical personnel, and the treatment facility—

(1) Retained, unexploded ordnance: these patients should be segregated immediately.

(2) Enemy Prisoners of War (EPWs)/Detainees: although treated the same as friendly casualties, it is essential that the threat of “suicide bombers” and “human booby traps” be prevented by carefully screening all EPWs prior to moving into patient areas

including triage area. Refer to Field Manual-Interim (FMI) 4-02.46 for more information on the medical treatment of detainees.

#### **4. Mission-Oriented Protective Posture Levels**

a. In a CBRN incident, not all casualties will be in MOPP gear. Military personnel will likely care for civilians casualties. As MOPP levels increase, individual protective equipment is added to the equipment worn at lower levels. Each increase in the MOPP level reduces the time troops must take to attain MOPP-4 and full protection. When the threat of CBRN use is high, commanders may establish a standing MOPP level (other than MOPP-0) for troops during military operations. In the event of a CBRN attack, this effectively reduces the time required to attain MOPP-4. The levels of MOPP are—

- MOPP Level 0—None of the protective clothing and equipment is worn, but it is readily available.
- MOPP Level 1 (Suspected)—MOPP suit on (jacket and trousers), carry boots, gloves, and mask.
- MOPP Level 2 (Possible)—MOPP suit on, boots on, carry gloves and mask.
- MOPP Level 3 (Probable)—MOPP suit on, boots on, mask on (with hood), carry gloves.
- MOPP Level 4 (Imminent)—All MOPP gear on.

b. The protective overgarment and hood can cause body heat buildup, which can lead to heat exhaustion in warmer weather. The protective mask and hood degrade the ability to see, speak, and hear. The rubber gloves restrict air circulation and limit the sense of touch and the ability to perform tasks requiring delicate manipulation. The wearing of full IPE or personal protective equipment (PPE) can cause psychological stress (such as claustrophobia) in some people. All of these problems can reduce the effectiveness of HSS. Therefore, flexibility in adjusting the MOPP levels should be exercised to meet mission requirements, environmental conditions, and the threat of CBRN exposure.

#### **5. Civilian Casualties**

Civilian casualties may become a problem in populated or built-up areas, as they are unlikely to have protective equipment and training. Roles 1 and 2 MTFs may be required to provide assistance when civilian medical resources cannot handle the workload. However, aid to civilians will not be undertaken without command approval or at the expense of health services provided to US personnel.

#### **6. Taxonomy of Care**

a. In JP 4-02, HSS offers seven distinctive and overlapping care capabilities that enhance performance in a military force. These capabilities circumscribe the entirety of HSS. They include the medical resources (personnel, materiel, facilities, and information) and the organizational enabling capacity to deliver HSS. All seven care capabilities are requisite to sustained health and are mutually supportive to that purpose. Each capability, however, has unique attributes that can be identified, improved, and applied to attain the desired well-being during a CBRN incident.

(1) Policy and Resource Acquisition Capability. All HSS CBRN capabilities are dependent on sound policy and sufficient resource acquisition. Policy provides the framework from which the HSS community derives the direction and identifies the requisite people, materiel, facilities, and information to promote, improve, conserve, or

restore well-being. With policy as the guide, resource acquisition occurs through planning, programming, budgeting, and disbursement of funds. This Title 10 United States Code activity is foundational to the HSS community's capability to organize, train, and equip sustainment forces.

(2) **Prevention and Protection Capability.** Health service support can support the warfighter in a CBRN environment by applying prevention and protection capabilities. These capabilities are both wide-ranging and diverse and match the complexity of human health needs. These capabilities are focused on the individual, while others are directed at the Family, organization, or force. Additionally, the Services will develop and enforce specific minimum standards; these standards will ensure Service members are free of diseases or medical and dental conditions that are incompatible with expeditionary military service.

(a) When focusing on the joint force, the medical portion of protection is labeled FHP. It includes all measures taken by commanders, leaders, individual Service members, and the MHS to promote, improve, or conserve the mental and physical well-being of Service members across the range of military operations. These measures enable a healthy and fit force, prevent injury and illness, and protect the force from health hazards.

(b) Members of the joint force have to be physically and mentally fit. This requirement demands programs that promote and improve the capacity of the personnel to perform military tasks at high levels under extreme conditions (for example, wearing of IPE) and for extended periods of time. These preventive and protective capabilities include physical exercise, nutritional diets, dental hygiene and restorative treatment, combat and operational stress management, rest, recreation, and relaxation geared to the individual or organization.

(c) Methods to prevent disease are best applied synergistically. Sanitation practices, waste management, pest and vector control are crucial to protection from disease. Regional spraying and the application of insect repellent to guard against hazardous flora and fauna are examples of prevention methods. Prophylactic measures can encompass human and animal immunizations, dental chemoprophylaxis and treatment, epidemiology, optometry, counseling on specific health threats, and issuance of protective clothing and equipment.

(d) Key to preventive and protective care is information the capacity to anticipate the current and future health environment and its proper delivery to the affected human population. Derived from robust health surveillance and medical intelligence, this information addresses occupational, natural environmental, and enemy-induced threats from industrial hazards; air and water pollution; endemic or epidemic disease; and CBRN and DE devices/weapons. The HSS system must be capable of acquiring, storing, moving, and providing information that is timely, relevant, accurate, concise, and applicable to the intended human user. In summary, this information capability is crucial to HSS.

(3) **First Responder Capability.** More than any other care service; the first responder capability is defined by its time requirements. It is this health care capability that provides immediate medical care and stabilization to the patient in preparation for evacuation to the next HSS capability in the continuum of care. This capability can offer primary care outpatient services, emergent care services, medical subspecialty services, and ancillary services.

(4) **Forward Resuscitative Capability.** This capability is characterized by the capacity to perform advanced EMT as close to the point of injury as possible, to attain

stabilization of the patient, and to achieve the most efficient use of life- and limb-saving medical treatment. The forward resuscitative care capability typically provides essential care for stabilization to ensure the patient can tolerate evacuation. This capability covers advanced emergency services, postsurgical inpatient services, surgical subspecialty services, and ancillary services.

(5) Theater Hospitalization Capability. This capability delivers HSS via modular hospital configurations and/or a hospital ship required to medically sustain forces in a theater. This HSS capability involves hospitals purposely positioned to provide in-theater support. Theater hospitalization capabilities deploy as modules or multiple individual capabilities that provide incrementally increased medical services in a progressively more robust theater. The theater hospitalization capability offers essential care to either return the patient to duty (within the theater evacuation policy and/or stabilization to ensure the patient can tolerate evacuation to a definitive care facility outside the theater.

(6) Definitive Capability. This capability is rendered to conclusively manage a patient's condition and is usually delivered from or at facilities in the homeland but may be delivered in OCONUS facilities outside the homeland. For the Service member this care capability normally leads to rehabilitation, RTD, or discharge from the Armed Forces. It includes the full range of preventive, curative, acute, convalescent, restorative, and rehabilitative medical care and it extends to the families of members of the armed forces and Service retirees.

(7) En route Capability. The purpose of an en route capability is the continuation of care during movement (evacuation) within the HSS roles of care without clinically compromising the patient's condition. Patient movement involves transitory medical care, patient holding, and staging capabilities during transport from the site of injury or onset of disease, through successive capabilities of medical care, to an MTF that can meet the needs of the patient. Each Service component has an organic patient movement capability for evacuation from point of injury to initial treatment at an MTF.

(a) En route capability can take three forms. Casualty evacuation (CASEVAC) involves the unregulated movement of casualties aboard ships, land vehicles, or aircraft. Medical evacuation refers to dedicated medical evacuation platforms staffed and equipped to provide en route medical care using predesignated tactical or logistic aircraft, boats, ships, and other watercraft temporarily equipped and staffed with medical attendants for en route care. Aeromedical evacuation (AE) specifically refers to USAF fixed-wing movement of regulated casualties, using organic and/or contracted mobility airframes, with AE aircrew trained explicitly for this mission.

(b) On today's lethal battlefield, the reduced medical footprint forward, and the *evacuate and replace* philosophy, place a high demand on the en route care capabilities of all Services. Consequently, patient movement capabilities are even more critical than in the past and Service medical elements must integrate with lift operations, as well as with the associated capabilities of our Nation's allies and coalition partners.

b. For more information on the taxonomy of care, refer to JP 4-02.

## **7. Roles of Care**

a. The US military doctrine supports an integrated and capability-based health care system to triage, treat, evacuate, and return Soldiers to duty in the most efficient time and manner. The US Army uses roles of care (previously referred to as *levels and echelons*) to denote differences in capability rather than the quality of care. Each role has the capability of role forward of it and expands on that capability. The Army Medical Department

(AMEDD) is using terminology of roles of care with some modifications on the definition to meet US Army requirement. For information on the NATO definitions of roles of care, refer to STANAG 2228/AJP-4.10 (A) and the *Emergency War Surgery Handbook*.

b. Role 1. Care consists of care rendered at the unit level. It includes self-aid, buddy aid, and CLS skills, examination, and emergency lifesaving measures. Examples include the maintenance of the airway, control of bleeding, prevention and control of shock, splinting or immobilizing fractures, and the prevention of further injury. Treatment may include restoration of the airway by invasive procedures; use of IV fluids and antibiotics; and the application of splints and bandages. These elements of medical management prepare casualties for RTD or for evacuation to a higher role of care. Supporting medical units are responsible for coordinating the movement of patients from supported MTFs. The USMC Role I capabilities include only first aid (self-aid, buddy aid) and emergency care provided by a unit corpsman, battalion aid station (BAS), shock trauma platoon, and Marine wing support group. In the USAF, the first two roles of care (Roles I and II) are normally provided at a deployment location and emphasize self-aid and buddy care. Casualties become medical patients when a medical diagnosis and treatment sequence have been determined.

c. Role 2. Care includes physician-directed resuscitation and stabilization and may include advanced trauma management (ATM), EMT procedures, and forward resuscitative surgery. Supporting capabilities include basic laboratory, limited x-ray, pharmacy, and temporary holding facilities. Casualties are treated and RTD or are stabilized for movement to an MTF capable of providing a higher role of care. Ground or air movement is coordinated for transfer the patient to a facility possessing the required treatment capabilities. Role 2 is the first role where Group O packed red blood cells (Rh+-) will be available for transfusion. The medical battalion's surgical company and the forward resuscitative surgery system are the only units in the USMC that provide Role II care.

d. Role 3. Care is administered that requires clinical capabilities normally found in a facility that is typically located in a reduced-level enemy threat environment. The facility is staffed and equipped to provide resuscitation, initial wound surgery, and postoperative treatment. This role of care may be the first step to restoration of functional health, as compared to procedures that stabilize a condition to prolong life. Blood products available may include fresh frozen plasma and Group A, B, and O liquid cells and may also include frozen Group O red cells and platelets. The USMC care at Role III and above is provided by other Services as determined by the JFC.

e. Role 4. In addition to providing surgical capabilities found at Role 3, this role also provides rehabilitation and recovery therapy. Definitive care includes the full range of acute, convalescent, restorative, and rehabilitation care and is normally provided in CONUS by military and the Department of Veterans Affairs hospitals, or civilian hospitals that have committed beds for casualty treatment as part of the National Disaster Medical System (NDMS). On occasion, OCONUS military or allied/coalition and/or host nation hospitals approved by the CCDR as safe havens may also be used. This role may include a period of minimal care and increasing physical activity necessary to restore casualties to functional health and allow them to RTD or to a useful and productive life.

## **8. Role 1 Health Service Support in a Chemical, Biological, Radiological, and Nuclear Environment**

a. When operating under a CBRN threat or when a CBRN attack is imminent, the MTF must prepare for continuation of its mission. Should an attack occur or a downwind hazard exist, the MTF must seek out a contamination free area to establish a clean treatment area

or must establish collective protection to continue the mission. Some MTFs have chemical biological protective shelter (CBPS) systems. When available, these systems serve as the primary shelter for the MTF; they are operated in the full CB mode when attack is imminent or has occurred. See Chapter XI for information on establishing an MTF in a CBPS system. When operating in the CB mode only patients requiring life- or limb-saving procedures are allowed entry into the MTF. Patients that have minor injuries that can be managed in the contaminated EMT area of the PDS will receive treatment in this area. Patients with injuries that require further treatment, but can survive evacuation to the Role II MTF will have their MOPP immediately decontaminated, their injuries managed, the integrity of their MOPP restored, and be directed to an evacuation point to await transport to the Role II MTF. When patients or personnel are contaminated or are potentially contaminated, they must be decontaminated before admission into the clean treatment area (see FM 3-11.5/MCWP 3-37.3/NTTP 3-11.26/AFTTP[I] 3-2.60 for personnel decontamination procedures and Chapter V for patient decontamination procedures).

b. Select sites for Roles 1 and 2 MTFs that are located away from likely enemy target areas. Cover and concealment is extremely important; they increase protection for operating the MTF.

c. Operating a CBPS system in the CB mode at the BAS requires at least eight medical personnel. The senior health care NCO performs patient triage, limited EMT, and minor injury care in the PDS. One health care specialist supervises patient decontamination and manages patients during the decontamination process. Two trauma specialists work on the clean side of the hot line and manage the patients until they are placed in the clean treatment area or are sent into the CBPS for treatment. They also manage the patients that are awaiting medical evacuation to the Role 2 MTF. The physician, physician assistant, and two health care specialists provide ATM in the clean treatment area or inside the CBPS. See Chapter XI for CPS entry/exit procedures.

d. When Roles 1 and 2 MTFs are receiving CBRN contaminated patients, they require at least eight nonmedical personnel augmentees from supported units to perform patient decontamination procedures under medical supervision. These MTFs are only staffed with medical personnel to provide patient care under conventional operational conditions. Without the augmentation support, they can either provide patient decontamination or patient care, but not both.

## **9. Role 2 Health Service Support in a Chemical, Biological, Radiological, and Nuclear Environment**

a. Role 2 HSS responsibilities include, but not limited to—

- Evacuating patients from the BAS and medical evacuation on an area support basis from within the brigade sustainment area.
- Providing Role 1 medical treatment on an area support basis.
- Operating the medical company Role 2 MTF, which provides a patient holding capability for up to 40 patients for 72 hours. See FM 4-02.6 for detailed information on Role II conventional HSS operations.
- Providing limited dental service.
- Providing limited PVNTMED support in the areas of medical surveillance, OEH surveillance, food service sanitation, water quality control (including CBRN contamination surveillance), and communicable disease control.
- Providing limited COSC; these patients are returned to duty as their condition permits.

b. In the division, corps, and echelons above corps (EAC), Role 2 MTFs are the same as for the brigade, except patients may be evacuated from a forward Role 2 MTF, as well as from a BAS.

c. When operating under a CBRN threat or when a CBRN attack is imminent, the Role 2 MTF must prepare for continuation of its mission.

d. Forward Surgical Team (FST). Forward Surgical Teams are either organic to divisional and nondivisional medical units or are forward deployed in support of divisional or nondivisional medical companies to provide a surgical capability. Refer to FM 4-02.25 for more information on FST operations. However, when forward deployed and CBRN contamination is imminent, the FST must employ collective protection in order to continue its support mission. When operating in a contaminated area, the FST CBPS system must be complexed with the Role 2 MTF CBPS system. The FST cannot operate in a CBRN environment without the support of the Role 2 MTF. They do not have the capability to decontaminate patients. All patients are decontaminated in the Role 2 MTF PDS. They are then processed into the EMT section of the Role II MTF, where they are triaged and routed to the FST for surgery, if required.

## **10. Role 3 Health Service Support in a Chemical, Biological, Radiological, and Nuclear Environment**

a. Many factors must be considered when planning for Role 3 MTF support on the integrated battlefield. The MTF staff must be able to defend against threats by individuals or small groups (two or three) of infiltrators and survive CBRN strikes or TIMs incidents while continuing their mission. This threat may include the introduction of CBRN or TIM in the MTF area, the water or food supplies and the destruction of equipment and/or supplies. On the larger scale of surviving CBRN strikes and continuing to support the mission, operating in a contaminated environment will present many problems for hospital personnel. The use of CBRN weapons or TIMs release can compromise the quality and quantity of health care delivered by medical personnel due to the contamination at the MTF, constrain mobility and evacuation, and contaminate the logistical supply base. While providing hospital support, consider the following assumptions—

(1) Their location, close to other support assets, makes them vulnerable to CBRN strikes and release/dispersion of TIMs.

- Command, control, communications, computers, and intelligence infrastructure, logistical nodes, and base clusters are high value targets.
- Most CBRN weapons are designed for wide-area coverage. Chemical warfare and BW agents may present a hazard some distance downwind from the area of attack; also, residual radiation may extend for hundreds of kilometers (km) from ground zero.
- The large signature (size, heat, or infrared) of a hospital makes it easy to find and target (the assumption is that the hospital is very near the intended targets).
- Medical treatment facilities located near road networks and airfields for access to evacuation routes increase their exposure to tactical strikes of CBRN weapons and exposure to TIMs releases.

(2) There are an ever-increasing number of countries and individuals with the ability to manufacture and deliver CBRN weapons/agents. This activity increases their use potential at all levels of conflict. Refer to Table I-5 for listed countries.



---

Note: When using existing civilian hospitals, the materials for a RDD may be at these hospitals. Exploding the material in place is very practical for a small team of terrorists.

---

(3) In addition to the wounding effects of CBRN weapons on troops, their use will have other effects upon the health care delivery system.

(a) Follow-on treatment may have to be delayed due to the need for patient and facility decontamination.

(b) The arrival of contaminated patients at the MTF will require MTF personnel to perform triage; administer EMT procedures in the patient decontamination area; supervise augmentation personnel performing patient decontamination; and constantly monitor the hospital for contamination. A Role 3 MTF requires at least 20 nonmedical personnel from supported units within the geographic area/base cluster of the hospital to perform patient decontamination under medical supervision.

(c) Patients may have been triaged and decontaminated at a Role 1 or Role 2 MTF. However, all patients must be triaged and checked for contamination as they arrive at the Role 3 hospital ambulance drop off point. Triage ensures patients receive life- or limb-saving care in a timely manner. If patients are arriving from a suspected CBRN contaminated area, they must be decontaminated before admission into the clean treatment area of the MTF. The patient decontamination area is established on the downwind side of the MTF. When the MTF does not have collective protection, the patient decontamination point must be at least 50 yards downwind of the hospital entry point. When the MTF is located inside a base cluster, the patient decontamination area may have to be established some distance from the MTF to prevent contamination of other units in the area. Should this be the case, the patients may have to be transported by ambulance or other vehicle from the clean side (hot line) of the patient decontamination area to the receiving point of the hospital.

b. Medical treatment facilities are not kept in reserve. All HSS personnel and equipment losses due to CBRN contamination or radiation will have to be replaced.

## **11. Management of Chemical, Biological, Radiological, and Nuclear Casualties in a Medical Treatment Facility**

a. Defense Planning Against Use of CBRN Weapons/Agents. Many factors must be considered when planning for hospitalization on the battlefield. To the maximum extent possible, MTFs are located away from tactical or logistical targets. The MTF staff must be able to defend against a CBRN threat and survive CBRN strikes while continuing their mission.

---

Note: Medical units should ensure that they have an ample supply of 7 mil butyl rubber gloves available so that staff can continue to perform medical procedures that require the ability to palpate and still have finger dexterity for fine motor tasks.

---

b. Without a CBPS system, MTFs may operate for a limited time in a nonpersistent agent environment, but are incapable of operating in a persistent agent environment.

(1) Chemical/biological filters will be a critical item of supply. Therefore logistics activities must ensure that sufficient quantities of replacement filters are available or are on order to meet mission requirements. Logistics will also be responsible for the safe disposal

of the filter and all of the contaminated equipment that cannot be decontaminated (tentage, plastic sheets, blankets, linens, and contaminated uniform items).

(2) Liquid CW agents can penetrate the tent, extendable, modular, personnel (TEMPER) in about six hours or the general purpose (GP) tentage in a shorter period of time. These agents can penetrate the standard/packaging wrappings on medical supplies, sterilized equipment and supplies, and medications/solutions that come in contact with agent liquid, vapor, or contaminated dust. The vapor, liquid, and dust can also contaminate open water/food supplies. It is critical that these items be in a covered area or covered containers prior to an attack.

(3) Without a CPS, treatment procedures in an actively contaminated area involving an open wound or the respiratory tract are limited. Exposing open wounds and the respiratory tract can provide a route of entry for the CBRN agent. Without hardened protection, the MTF, staff, and casualties are susceptible to the blast, heat, and missile effects of nuclear weapons.

(4) The MTF's medical equipment is vulnerable to the effects of the EMP produced by nuclear weapons. The EMP has no known harmful effects to humans, animals, or plants, but is very damaging to electronic equipment. It is very difficult to decontaminate most medical equipment. Decontamination may only be possible by aging (allowing the agent to off-gas).

(5) Medical treatment facilities are not kept in reserve. All personnel and equipment losses due to CBRN contamination will have to be replaced by out-of-theater resources. For more information on CPS, refer to Chapter XI.

## **12. United States Marine Corps Operations Casualty Management**

a. Casualty management in USMC operations poses some interesting challenges. There are three scenarios (shipboard, sustained operations ashore, and amphibious operations) that must be addressed by USMC HSS resources.

b. Shipboard. Ships may become contaminated directly as a result of an actual hit or nearby airburst. Clouds of vapor or aerosols which drift offshore may also contaminate ships indirectly. Initial casualties, which will primarily be exposed deck personnel or personnel within spaces contaminated by penetrating chemical munitions, should be moved to a collection area where initial triage and hasty decontamination can be performed before transfer to the ship's medical department.

c. Sustained Operations Ashore. These operations are generally characterized by established bases and logistical support.

d. Amphibious Operations. Casualties will be moved from the point of illness or injury to different roles of care. Movement of the casualties may not progress through each role in sequence. Depending on the tactical situation and degree of air superiority, casualties may move from the point of illness or injury directly to Role III care. Nonambulatory casualties should be placed in PPWs before transfer between roles. In the early stages of amphibious operations, the assault force is extremely vulnerable because of the lack of established support base ashore.

### 13. Protection of Medical Treatment Facilities

a. Use of Intelligence Data and Planning. Protection of MTF assets requires intensive use of intelligence data and careful planning. The limited mobility of MTFs makes their site selection vital to minimize collateral damage from attacks on other units.

(1) Medical treatment facilities must be located as close to the supported troops as possible to provide responsive care. However, their limited mobility and a possible lack of CPS systems must be considered when selecting their locations.

(2) Protective factors (distance from other units and interposed terrain features) must be balanced against the operational factors (accessibility and time required for casualty transport).

(3) Regardless of the weapon system used, relatively large portions of any tactical area will remain uncontaminated. Medical treatment facilities should avoid movement through or operation in contaminated areas.

b. Planning for Defensive Measures. Many defensive measures will either impede or preclude performance of the MTF mission. A successful MTF defense operation against a CBRN threat is dependent on accurate, timely receipt of information via the CBRN reporting system. This warning data will allow MTFs to operate longer without the limitations and problems associated with MOPP use, and then adopt a defensive posture when absolutely necessary. The detailed information on the areas affected and the types of agents used allows the MTF staff to—

- Predict the number and types of casualties to be expected.
- Establish a casualty decontamination area.
- Request casualty decontamination assistance.

c. Protective Procedures. Because most MTF sections operate in sheltered areas (tentage or ISO shelters), some protection is provided against vapor, liquid, and particulate (fallout) hazards. Positioning equipment (such as trucks) under trees or other cover provides similar effects. Setting up MTFs in existing structures (concrete or steel buildings) provides the maximum protection from hazards and eliminates many decontamination problems.

---

Note: This paragraph implements STANAG 2931.

---

(1) Concealment and good operations security (OPSEC) will help prevent identification of a unit. However, camouflaging the MTF must be weighed against the loss of Geneva Conventions protection. The NATO STANAG 2931 provides for camouflage of the Geneva emblem on medical facilities where the lack of camouflage might compromise tactical operations. Medical facilities on land, supporting forces of other nations, will display or camouflage the Geneva emblem in accordance with national regulations and procedures.

(2) When failure to camouflage would endanger or compromise tactical operations, the camouflage of medical facilities may be ordered by a NATO commander of at least brigade level or equivalent. Such an order is to be temporary and local in nature and countermanded as soon as the circumstances permit. It is not envisaged that large, fixed medical facilities would be camouflaged. The STANAG defines medical facilities as medical units, medical vehicles, and medical aircraft on the ground. Refer to STANAG 2931 and FM 4-02 for additional information.

(3) Dispersion is a defensive measure employed by tactical commanders; however, hospital operations limit the value of this technique. One technique that may be used is locating sections of the MTF (such as the motor pool, personnel billets, laundry, and logistical storage) further from the MTF complex than normal. This would increase dispersion without severely compromising the HSS mission.

(4) The MOPP will not protect personnel from external gamma and neutron radiation exposure. It will however protect personnel from external alpha particles and all but most energetic beta particles. Standard MOPP Level 4 affords excellent radiological *contamination* protection. Standard issue military protective masks (M-40 or equivalent) provide excellent protection from inhalation and ingestion of radioactive material.

## 14. Chemical Environment

a. Consider that all patients generated in a CW agent environment are contaminated. The vapor hazards associated with contaminated patients may require HSS personnel to remain at MOPP Level 4 for long periods. The MTF must be set up in clean areas or employ CPS. If there is liquid agent contamination or a continued vapor hazard, the MTF should be moved and decontaminated, mission permitting.

b. Initial triage, EMT, and decontamination are accomplished on the dirty side of the hot line. Life-sustaining care is rendered, as required, without regard to contamination. Normally, the senior medical personnel perform initial triage and EMT at the Role I MTF. Secondary triage, ATM, and patient disposition are accomplished on the clean side of the hot line. When treatment must be provided in a contaminated environment outside the CPS the role of care may be greatly reduced because medical personnel and patients are in MOPP Level 4. However, lifesaving procedures must be accomplished. See FM 4-02.285/MCRP 4-11.1A/NTRP 4-02.22/AFTTP (I) 3-2.69; 8-500; and the *Medical Management of Chemical Casualties Handbook* for specific treatment of CW agent patients. Decontamination of most chemically contaminated patients and equipment requires the use of materials that will remove and neutralize the agent. See FM 3-11.5/MCWP 3-37.3/NTTP 3-11.26/AFTTP(I) 3-2.60 for military equipment decontamination procedures and Chapter V for specific casualty decontamination procedures.

### WARNING

**Cross-contamination of patients by decontamination personnel can result in further injury to the patient. Decontamination personnel handling patients must not have been involved in decontamination operations or be thoroughly decontaminated prior to handling patients. Bleach requires contact time with agent for complete neutralization dependent on the ambient temperature. Ensure decontamination personnel have waited a sufficient amount of time before handling patients to allow for this contact time to neutralize agent.**

c. Chemical Protection.

(1) Individual protection. When CPS systems are not available, using the correct MOPP level is essential in MTF mission performance. The level of MOPP assumed depends upon the level of threat.

(a) An alternative approach for the MTF commander is the use of the mask-only posture. This posture is acceptable when the hazard is from vapor only (such as nonpersistent agents). Casualties and personnel in tents and expandable shelters are protected from solid or liquid contamination (transfer hazards for a limited time). Personnel can work efficiently and for longer periods in mask-only posture instead of MOPP Level 4. However, the commander must weigh these factors against the potential contamination transfer risk. This risk should be small, except in areas where casualties or materiel are received from the outside. Individuals returning to or bringing materiel from the outside must be extremely careful not to bring contamination into the mask-only area. When considering this alternative, remember that except those casualties in PPW, the casualties must also be at mask-only posture.

(b) Medical facilities must ensure that they have an adequate supply of new replacement filters on hand for casualties as well as staff. Casualties who have gone through decontamination will need to have their filters replaced immediately after decontamination. Decontamination team members will need to have their filters replaced frequently if they come in contact with large amounts of contamination. The MTF personnel should plan for the safe storage and disposal of patient and medical staff's contaminated respirator filters.

(c) The MTF must have a warning system that alerts all personnel of impending or present hazards. This system must include visual and auditory signals; the signals must operate inside and outside of the MTF complex. There are numerous problems associated with warning personnel; they include—

- The wide area covered by MTF operations.
- Some shift personnel will be asleep at all times of the day or night.
- The considerable noise from the power generation and environmental control equipment.
- Tentage and equipment, which interrupts the line of sight.

(2) When the CBRN alarm is activated, all personnel (including off duty personnel) report to their duty stations as soon as they are in MOPP. This allows for 100 percent personnel accountability and provides additional personnel to secure casualties and materiel.

(3) With all openings secured and the ventilation system turned off, the nonchemically protected MTF is at its best posture. For nonpersistent agents (vapor hazards), personnel and casualties stay at the designated MOPP level until the all clear signal is given; then normal operations are resumed.

---

Note: Casualties with injuries that prevent them from assuming a protective posture should be evacuated immediately to a clean treatment facility.

---

#### d. Casualty Protection.

(1) Casualty protection depends on prior planning and timely warning of the chemical threat. Each casualty's protective mask must be available and serviceable. If the casualty came from a contaminated area, the mask must be decontaminated and the filter changed. The mask decontamination and filter change may have to be performed by MTF personnel. If ambulatory casualties' medical conditions permit, they may be able to perform this task. Check all masks for serviceability as soon as the mission permits, although this should have been checked prior to deploying to the AO. Do not wait until the warning has been received to begin checking the mask. Each area must have an established plan for

operations (to include assisting casualties assuming MOPP or other protective posture) in the CBRN environment.

(2) Medical treatment facility personnel always mask themselves first and then assist casualties in masking. On minimal care wards, most casualties can put on their own masks. For those who cannot, other casualties can assist them after putting on their own masks. On the intermediate care wards, some casualties will be able to put on their masks, but many will require assistance.

(3) Many casualties with head and neck wounds or who are on life-support devices will be unable to wear their individual protective masks; these casualties must be placed in PPWs with blowers. While the PPWs have two ports for IV or blood infusion lines, the staff may have to adapt for other devices (Foley® catheters, traction, and cardiac monitors) by using tape and other means to seal the gaps created in the seal around the edge of the PPW. Casualties requiring assisted ventilation are at extreme risk, unless their air supply is protected. The sequence of protecting everyone is mask yourself first; assist those patients who can wear their protective masks; and then place those patients who cannot mask in the PPW. Specific treatment information for the treatment of radiological casualties is found in FM 4-02.283/NTRP 4-02.21/AFMAN 44-161(I)/MCRP 4-11.1B, and the AFRRl's *Medical Management of Radiological Casualties Handbook* (<http://www.afrrl.usuhs.mil/outreach/pdf/2edmmrhandbook.pdf>).

(4) Materiel protection. Protection of materiel, especially expendable supplies, requires covers and barriers. All materiel not required for immediate use is kept in shipping containers, medical chests, or under cover (such as tentage, plastic sheeting, or tarpaulin) for protection against particulate or liquid hazard. Protection against vapor hazard may require multiple barriers through which the vapor must penetrate. For example, IV solutions are in their individual plastic bags, in the cardboard shipping box, on a covered pallet, or in a military van (MILVAN). This presents four barriers against the vapor hazard. These principles should be used to the maximum extent practical.

e. Environmental protection. As noted previously, the MTF offers some protection against liquid or fallout contamination, but little protection against vapor hazards.

(1) When MOPP Level 2 posture must be assumed, close and secure all tent flaps, vents, and doors to prevent the entrance of liquids or particles. All MTF personnel outside of shelters assume command-directed MOPP level. Cover or move all equipment and supplies into shelters if possible. Keep all equipment and supplies not immediately needed covered or in closed containers.

(2) When MOPP Level 3 or mask-only posture is assumed shutdown the MTF ventilation system if in a nonchemically protected facility to prevent drawing vapors or fallout contamination into the MTF. This measure provides some protection of the internal environment during the time required for the vapor to penetrate the tentage. For chemically protected facilities keep the ventilation on to maintain positive airflow.

## **15. Biological Environment**

a. A BW agent attack (such as the enemy use of bomblets, rockets, spray or aerosol dispersal, release of arthropod vectors, and terrorist or insurgent contamination of food and water) may be difficult to recognize. Airborne dissemination of BW agent exposure is the likely means of delivery. While such agents may produce large numbers of casualties, initial casualties may be seen at the MTF in small numbers. When a trend is identified, the use of a BW agent may be suspected. General protective measures are the same as for any

infectious disease; specific protective measures are used once the vector or method of transmission has been identified.

b. Designating a single MTF to care for these patients (from a casualty care or disease transmission standpoint) may not be necessary. However, if there are a limited number of cases, consolidating them all at one facility maximizes the use of limited diagnostic laboratory and personnel assets. Biological warfare attack protective measures are the same as the measures for CW agents when bombs, sprays, or aerosols are used. The difficulty in rapidly identifying BW agents may force the use of higher levels of MOPP for longer periods of time. Faced with this situation, a careful evaluation of the mask-only posture is necessary before implementing any level of MOPP.

c. Quarantine, exposed personnel or isolation of casualties may be warranted in some cases, particularly with infectious biological agent exposure. If these situations exist, then quarantine and isolation procedures should be followed. For additional information, refer to FM 8-284/NTRP 4-02.23/AFMAN (I) 44-156/MCRP 4-11.1C; AFTTP 3-42.3; AFTTP 3-42.22; and current Air Force directives on isolation procedures.

d. Frequently, BW agent exposure does not have an immediate effect on exposed personnel. All HSS personnel must monitor for BW agent indicators such as—

- Increases in disease incidence or fatality rates.
- Sudden presentation of an exotic disease.
- Other sequential epidemiological events.

e. Passive defensive measures (such as immunizations, good personal hygiene, physical conditioning, using insect repellents, wearing the protective mask, and practicing good sanitation) will mitigate the effects of many BW agent intrusions.

f. Health service support commanders and leaders must enforce contamination control to prevent illness or injury to HSS personnel and to preserve the MTF. Incoming vehicles, personnel, and patients must be surveyed for contamination. Ventilation systems in MTFs (without CPS) must be turned off if BW agent exposure is imminent.

g. Decontamination of most BW agent contaminated patients and equipment can be accomplished with soap and water. Soap and water will not kill all biological agents; however, it will remove the agent from the skin or equipment surface. See Chapter V for specific casualty decontamination procedures.

h. Treatment of BW agent patients may require observing and evaluating the individual to determine necessary medications, isolation requirements, or medical management procedures. See FM 8-284/NTRP 4-02.23 (NAVMED P-5042)/AFMAN (I) 44-156/MCRP 4-11.1C and the USAMRIID's *Medical Management of Biological Casualties Handbook* (<http://www.usamriid.army.mil/education/instruct.htm> [select "download Bluebook 6th Edition"]) for specific treatment procedures for BW agent contaminated patients.

i. Medical surveillance is essential. Most BW agent patients initially present with common symptoms such as low-grade fever, chills, headache, malaise, and coughing. More patients than normal may be the first indication of BW agent attack. Daily medical treatment summaries, especially DNBI reports, need to be prepared and analyzed. Trends of increased numbers of patients presenting with unusual or the same symptoms are valuable indicators of enemy employment of BW agents. Daily analysis of medical summaries can provide early warnings of BW agent use, thus enabling commanders to initiate preventive measures earlier and reduce the total numbers of troops lost due to the illness. See Chapter 2 of this publication and DODI 6490.03 for information of medical

surveillance procedures. See Chapter VII for suspected specimen collection, packaging, chain of custody documentation, and shipment to the supporting medical laboratory. See FM 8-284/NTRP 4-02.23 (NAVMED P-5042)/AFMAN (I) 44-156/MCRP 4-11.1C for preventive, protective, and treatment procedures.

## **16. Nuclear Environment**

a. The HSS mission must continue in a nuclear environment. Chemical, biological protective shelters are essential to continue the support role. Well-constructed shelters with overhead cover and expedient shelters (reinforced concrete structures, basements, railroad tunnels, or trenches) provide good protection from nuclear attacks.

b. Most protective measures against nuclear attack require engineer and/or intensive logistics support. This support includes placing sandbag walls around tents, digging trenches for casualty occupation, or constructing earthen berms. Occupying existing structures, depending upon their strength and potential flammability, may be the best protection against the effects of a nuclear strike. Leaving equipment packed and loaded until actually needed for operations will help protect materiel in a CBRN environment.

c. Personnel and casualty protection requirements will depend upon the threat.

(1) If the threat is nuclear fallout, the MTF structure provides protection; the fallout can be brushed or washed off. This allows protection while permitting casualty care to continue virtually uninterrupted. A need to relocate the MTF will depend upon the degree of contamination, the amount of decontamination possible, and the projected stay before a normal move in support of tactical operations.

(2) Medical treatment facility tentage alone offers little protection against blast and missile effects. If the casualties are to remain in the tents, they are placed on the floor. Place all equipment on the ground or as low as possible and secure all loose objects. In GP tents and TEMPER, sandbags can be piled around the base of the tent poles to add stability. The tent poles and casualties cots/beds should keep the canvas off the ground enough (if the tent collapses) to continue minimal casualty care.

(3) Medical treatment facilities are very susceptible to the thermal effect of a nuclear detonation. Tents will not provide protection against the thermal pulse. If the thermal effect (fires) is an impending threat, casualties and personnel in tentage must move to trenches or other nonflammable areas.

d. Armored vehicles provide some protection against the blast and radiation effects of nuclear weapons. Patients generated in a nuclear attack will likely suffer multiple injuries (combination of blast, thermal, and radiation injuries) that will complicate medical care. Nuclear radiation patients fall into three categories—

(1) The irradiated patient is one who has been exposed to ionizing radiation, but is not contaminated. They are not radioactive and pose no radiation threat to health care providers. Patients who have suffered exposure to initial nuclear radiation will fit into this category.

(2) The externally contaminated patient has radioactive dust and debris on his clothing, skin, or hair. This radioactive debris can cause burns if not removed quickly. This usually presents a housekeeping problem to the MTF, similar to the lice-infested patient arriving at a peacetime MTF. However, an accumulation of radioactive debris from several patients admitted to the MTF may present a threat to other personnel. The externally



contaminated patient is decontaminated at the earliest time consistent with required medical care. Lifesaving care is always rendered, when necessary, before decontamination.

(3) The internally contaminated patient is one that has ingested or inhaled radioactive material or radioactive material has entered the body through an open wound. The radioactive material continues to irradiate the patient internally until radioactive decay and/or biological elimination removes the radioactive isotope. Attending medical personnel are shielded, to some degree, by the patient's body. Inhalation, ingestion, or injection of radioactive material sufficient to present a threat to health care providers is highly unlikely.

- e. Medical units operating in a radiation fallout environment will face three problems:
- The MTF may be immersed in fallout, requiring decontamination and relocation efforts.
  - Patients may continue to be produced from continued radiation exposure.
  - The contaminated environment hinders medical evacuation operations.

f. Decontamination of most radiologically contaminated patients and equipment can be accomplished with soap and water. Soap and water will not neutralize radioactive material however; it will remove the material from the skin, hair, or material surface. The waste can become a concentrated point of radiation and must be managed and monitored. One way to mitigate waste is coordinate with the CBRN officer and the supporting engineer unit to construct containment areas for the contaminated wastewater.

## **17. Medical Treatment Facility Contamination Control**

a. The MTF must designate a hot line that delineates the area of possible liquid contamination (between the hot zone and warm zone). Contaminated casualties are evacuated across the hot line to the warm zone for triage and decontamination. After decontamination, the casualties are moved across the hot line to the cold zone for continued care and evacuation. The hot line (away from the MTF) is considered contaminated by liquid agent. The patient decontamination site is located in this area. The area on the other side of the hot line, near the MTF is considered the clean area and should be free from liquid contamination. No individual is to cross the hot line until decontaminated. See Chapter V for detailed information and for layout of the *zones of contamination*.

b. The hot line must be manned by personnel who can provide security to ensure that contaminated individuals do not enter the clean treatment facility or clean treatment area.

c. Engineering controls, such as concertina wire or other sturdy fencing material should be used when available to restrict travel across the hot line to the clean area, except through guarded ECPs.

d. At these ECPs, casualties are checked for contamination using the ICAM/CAM, M8 paper, or other detection devices.

- e. Providing emergency services will be complicated by several factors—
- Varying levels of treatment received prior to arrival at the MTF.
  - Combined conventional wounds and CBRN agent effects.
  - Heat-related complications associated with MOPP use.
  - Increased numbers of psychological casualties who must be triaged quickly to allow for treatment of those who need emergency management.
  - The need to have EMT personnel at the patient drop off point for triage—
    - EMT in the dirty area.

- Care in the decontamination area.
- Triage and care at the hot line.
- Care in the MTF in the clean area.
- The potential of having to triage and provide casualty care while in MOPP gear.
- Reduced ability for EMT personnel to communicate between the various phases of the decontamination/treatment process.
- The need to provide supervision/guidance to the nonmedical decontamination augmentation personnel from the supported units.

f. Contaminated casualties must be triaged in the decontamination area that is established at the MTF. Contaminated casualties will not be brought into the clean EMT area until decontaminated. All casualties are screened for contamination. Based on the initial screening, the casualty is routed to the contaminated triage station or to the clean triage station. Contaminated casualties are triaged, and then routed to the decontamination area or to the contaminated treatment area. Casualty admission to the clean treatment area may be delayed; however, life- or limb-saving care is provided in the contaminated treatment area before decontamination.

g. The provision of general medical services in the MTF will be continued with minimal interruptions in the CBRN environment. The noninvasive nature of these services allows their continuation at most MOPP levels. General medical services will be constrained by MOPP Levels 3 and 4 and the mask-only posture. Most of these constraints will be—

- Communication limitations.
- Loss of the oral route for administering medications to casualties.
- Limited ability to accurately evaluate the eyes, nose, and mouth of casualties wearing a protective mask.
- Reduced ability to perform examination/assessment of casualties in PPW or MOPP Levels 3 and 4.
- Inability to provide oxygen therapy or ventilator support to a casualty in a vapor hazard environment, unless a CB filter mask is available.
- Logistics constraints based upon the fact that key areas such as dietetics, supply, and laundry are not in inclined in the CPDEPMEDS. These services may be reduced or delayed in the CBRN environment.

#### h. Surgical Services.

(1) Surgical services will be severely limited in the CBRN environment outside of a CPS. At any level above MOPP 0, surgical services are halted if performed in an unprotected, contaminated area except for life- and limb-expedient procedures. These emergency procedures may be performed with limited contamination risk to the casualty if performed in a relatively contamination-free area (such as an EMT area that has not been contaminated by a CBRN attack) where MOPP gear is worn by staff only as a precautionary measure. Surgery cannot be safely performed outside a CPS in a contaminated area due to a variety of factors including—

- Lack of protected ventilation for casualties during and after surgery.
- Inability to maintain a sterile field while using MOPP gear.
- Direct access for the CBRN agent through open wounds to the circulatory and respiratory systems.
- Decreased dexterity and vision resulting from MOPP gear use.
- Inability to quickly place the casualty in a PPW should the need arise.

(2) Due to the relatively high number of trauma cases, MTF services may be severely constrained by CBRN contamination. The MTF location and the possible need for hasty relocation are two major planning considerations for the commander and staff.

(3) Casualty accounting and medical regulating are critical factors in the transfer of casualties from an MTF without CPS that must move out of a CBRN environment. Medical treatment facilities without CPS should stop receiving casualties when a persistent hazard is identified. Casualties should be transferred to a clean MTF.

i. Nursing Services.

(1) Providing nursing care in a contaminated medical treatment area without CPS is influenced by the amount of protective gear worn by the nursing staff and the casualties. The casualties may be in MOPP gear, in a PPW, or wearing only their protective mask; any of which will interfere with care. Nursing personnel may be at any MOPP level or in protective mask only.

(2) Direct assessment of a casualty's vital signs is extremely limited at MOPP Level 3 or 4; however, a carotid artery pulse can be taken by palpating the neck area. The casualty's respiratory rate and level of consciousness may be assessed visually. Palpitation of the blood pressure through a PPW may be possible if it is relatively strong or at least in the normal range. The casualty's temperature cannot be monitored; this is an area of concern due to the possibility of heat stress.

(3) Only gross neurological signs can be assessed through the PPW. However, even this assessment is complicated by the presence of miosis and by the health care provider's mask. Cardiac and urinary output monitoring is continued uninterrupted for casualties wearing a mask only and for casualties in the PPW.

(4) Oral hygiene and bathing are postponed until a safe environment is available (MOPP Level 2 or less). All toileting will occur within the MTF complex using a bedpan, a urinal, a bucket, a container with a plastic liner, or a chemical toilet.

(5) At MOPP Level 3 or 4, feeding must be postponed. A nutritional assessment is needed to determine how long each casualty can tolerate a fasting state when the MOPP Level 3 or 4 remains for over 24 hours.

(6) Intravenous medications are mixed in a CPS area or in a clean area and then transported in a protective wrap (such as multilayers of plastic, medical chest, or layered cardboard) to the user. However, IV solutions, blood, and injections can be given to casualties in an unprotected ward. Normally, oral medications are only given at MOPP Level 2 or lower.

(7) Treatment procedures that have the potential of contaminating the casualty's pulmonary or circulatory systems are conducted only at MOPP Level 2 or below. However, EMT procedures may have to be performed in the contaminated treatment area or the casualty decontamination area.

(8) Continuous oxygen therapy requires a collective protection environment or a CB filter-supported respirator.

(9) Delivery of nursing care at MOPP Level 3 or 4 is limited due to the sensory restrictions of MOPP gear. Time is taken to reassure the patients on a personal basis, as much as possible, and by routinely monitoring the ward environment. Communications are difficult and identities are masked. Use of handwritten name tags for staff and casualties (including casualties in PPW) is required to ensure the identity of all personnel.

(10) As with all procedures, the time required for recordkeeping rises markedly at MOPP Level 3 or 4. Contaminated paperwork cannot be evacuated with the casualty. Transcribe essential information onto uncontaminated documents for evacuation with the casualty. A record of casualty exposure time to a contaminated area is prepared to assess the cumulative risk to the casualty.

(11) Dressing changes cannot be performed while the casualty is in a PPW or at MOPP Level 3 or 4.

(12) Chest tubes and nasogastric tubes in a contaminated environment should be managed in a way similar to the administration of IV fluids. Casualties with these tubes will require close monitoring.

(13) Nursing staff should be monitoring the patient's psychological status. Casualties may require additional monitoring for stress reactions when placed in a PPW or MOPP suit.

j. Dental Services.

(1) General. Dental service support is provided at the AO at Roles 2, 3, and 4. Since dental units have a bigger footprint and are collocated with other support assets, they are vulnerable to a CBRN strike. The CBRN operations have an impact at all levels; thus, dental units must be prepared to survive on the integrated battlefield. Defense against CBRN weapons must be included in the dental unit's SOP. Individual and collective tasks must be intensely trained on a regular basis. Survival depends on the ability of personnel to use basic survival skills against a CBRN attack.

(2) Mission in a CBRN Environment. The overall mission of dental units to provide dental services is greatly affected in the aftermath of a CBRN attack. First, the unit must survive the attack and rapidly recover from its effects. Secondly, in the event of mass casualties, care must be redirected to the alternate wartime role of augmenting the adjacent MTF. Dental units do not possess CPS therefore, providing dental services in a CBRN environment will be limited to treatment of maxillofacial emergencies requiring immediate attention. This care will be provided at an MTF in a CPS.

(3) Dental Treatment Operations. As a general rule, in the aftermath of a CBRN attack, dental treatment operations will cease until deliberate decontamination of the unit and its equipment has been accomplished. Only maxillofacial injuries, of an immediate life-threatening nature, should be treated. After a CBRN attack, the resources of the dental unit are redirected toward support of any mass casualty situation that may have been generated at an adjacent MTF or toward decontamination and relocation to a noncontaminated area. Although the likelihood to treat dental patients in a CBRN environment is extremely low, dental units must have plans for providing dental services.

(4) Patient Decontamination. Decontamination of patients is an absolute requirement before admission into a clean MTF or dental facility. Contaminated patients are triaged and decontaminated before treatment (except for life- or limb-saving care). Both triage and decontamination should be accomplished as far forward as possible. Specific details on patient decontamination are in Chapter V. It is important to note that medical or dental personnel do not normally perform patient decontamination. Immediate decontamination at the basic skill level is accomplished in place or at the casualty's unit. Thorough patient decontamination is accomplished by the patient decontamination teams (made up of nonmedical personnel [augmentees] from the supported units) that are supervised by medical personnel at the MTF. For more information, refer to Chapter V.

(5) Patient Decontamination at Dental Treatment Facilities (DTFs). Neither dental units nor their DTFs are equipped for patient decontamination. Contaminated patients arriving at a DTF requiring urgent attention must be directed or evacuated to the nearest MTF with a patient decontamination capability.

(6) Patient Protection Status. Dental treatment facilities must also consider the need to protect patients in their care in the event of a CBRN attack or when the threat of an attack is high. Special consideration must be made for maxillofacial patients whose condition prevents them from wearing protective masks.

(a) Immediate Response. In the event of an attack or when the alarm sounds, dental providers and patients immediately cease work and mask. Only after putting on their own mask, do the dental treatment providers assist the patient, if necessary, by removing material that impedes the patient's masking. Only those materials that impede masking or may compromise the airway (such as rubber dam frames or impressions) are removed. The rest are left in place until the all clear is sounded. Special attention must be given to medicated patients in less than a fully conscious state or that are incapacitated.

(b) Mission-Oriented Protective Posture Considerations. The MOPP level should be taken into account when determining the category and extent of dental treatment. Patients should be at the MOPP level prescribed for the dental facility by its parent headquarters. Dental treatment at MOPP Levels 3 and 4, of course, is impossible because of the requirement to wear the protective mask. However, treatment is still possible at MOPP Levels 0, 1, and 2. Treatment at MOPP Level 2 should be limited only to emergency care requiring urgent attention. At MOPP Level 1, most types of dental emergencies can be accommodated. However, only minimal essential treatment should be undertaken to reduce the risk of the patient being caught in a compromised state. At MOPP Level 0, the provision of dental treatment generally is not limited. The degree of the CBRN threat forecast for the area should be considered before undertaking extensive treatment.

(c) Oral and Maxillofacial Injuries. Patients with maxillofacial injuries that prevent proper fit and seal of the individual protective mask must be placed in a PPW. Though patients with these types of injuries are most likely found in MTFs, DTFs should nevertheless be prepared for patients presenting to the DTF. Since the DTF does not have any PPWs, these patients should be immediately evacuated to the adjacent MTF for treatment.

## **18. Medical Treatment Facility Decontamination**

a. The decontamination of MTFs and mission-essential surfaces and equipment requires a well-thought-out process. Fixed-site decontamination capabilities must be planned, coordinated, tested, and adapted for each MTF prior to a CBRN incident. Mobile decontamination equipment capabilities may be available at a fixed site to decontaminate buildings, equipment, roads, ramps, and helipads. Loading docks, entries and exits, and building exteriors can be decontaminated with more conventional methods such as using super tropical bleach (STB) and soap and water. Commanders should identify all systems that are capable of contributing to the decontamination effort (for example, water hydrant, fire hoses, fire trucks, steam cleaners, and water pumps). The commander should designate and train teams that can perform decontamination for fixed-site operations.

b. The decontamination of an MTF consists of two parts: interior and exterior.

(1) Interior. When conducting decontamination of the interior of an MTF, the following activities must occur—

- Secure the area or facility.
- Sample to confirm and determine the extent of the contamination.
- Evaluate the sampling results.
- Isolate the areas to prevent the spread of the contamination.
- Remove critical objects for special decontamination procedures.
- Ensure that contamination is not spread or transferred during movement.
- Decontaminate localized areas of the contamination.
- Properly manage the contaminated waste from the decontamination process.
- Continue monitoring and protecting against low-level exposure risks.
- Document and record the decontamination operations.

(a) Medical Equipment. Moisture, dust, and corrosive decontamination materials can damage unsealed electronic equipment circuitry (such as x-ray machines, electrocardiogram, or respirators). Most field electronic equipment is watertight for environmental protection which provides good protection against CBRN contamination. Contamination will probably not penetrate gasket-equipped protective covers and sealed components on electronic equipment; but if exposed, the contaminants may be present on the outside of cases containing the electronic equipment. The outside portions of the equipment case must be wiped down with a designated decontaminant. After decontaminating the outside, the equipment must be wiped down with water or an approved solvent to remove traces of decontaminant solutions. If equipment seals appear damaged or the penetration of CBRN contamination into the inside of the equipment is suspected, then the unit should be treated as if it was unsealed. Under no circumstances should electronic equipment be immersed in a decontaminant solution or subjected to high-pressure application of decontaminant solutions.

(b) Optics. Optical systems are extremely vulnerable to decontamination materials that might scratch or adversely affect the lenses. Wipe optical systems with a soft, nonabrasive material such as a lens-cleaning tissue, cotton wadding, or a soft cloth dipped in hot, soapy water. Wipe the optical system with decontaminants. Do not immerse it.

(c) Medical Supplies. Some medical supplies tend to absorb CW agents and may not be decontaminated and reused. Decontamination is difficult. It may be necessary to burn or bury them if they are heavily contaminated with a CW agent. Either STB dry mix or slurry may be used. Slurry is more effective. In many cases, weathering and rinsing with soap and water may be the preferred decontamination technique if the medical supplies are sealed. If the nonexpendable medical items (such as surgical instruments) must be decontaminated, boiling for 1 hour in soapy water is the preferred decontaminant for chemical and biological contamination. Radioactive contamination can be removed by brushing and then washing. It may also be vacuumed. If CBRN protective covers (tarps or poncho) were used to protect the medical supplies from contamination during a CBRN incident/attack. These covers should be decontaminated, buried or destroyed after use.

(2) Exterior. Many materials may absorb contamination and may not be completely decontaminated. The removal or sealing (painting) of these surfaces may be required to reduce the hazard. Continue monitoring the decontaminated surfaces until the detector indicates there is no more off-gassing. As temperatures rise, off-gassing of previously

contaminated surfaces may occur at detectable levels. A point detection device (for example, ICAM/CAM) should be used to monitor contaminated surfaces.

(a) Structures. Wood and concrete tend to absorb liquid agents and they may give off toxic vapors for days or weeks. Building decontamination is very difficult and requires large quantities of decontaminants. Covering the contamination with plastic sheets, STB slurry, sodium silicate, or other substances that cover or absorb the agent can reduce the hazard. Even though a particular part of a building is not intended for occupation, it may still need to be decontaminated to prevent the contamination from spreading.

(b) Ramps, roads and helipads. Ramps, roads and helipads also absorb liquid agents and then give off toxic vapors when heated by the sun. These surfaces may need to be decontaminated several times to reduce hazards. Streets, sidewalks, or other porous surfaces are best decontaminated by weathering if the time and the situation permit.

(3) Weathering. Weathering can increase the evaporation of liquid contamination. In a hot, sunny environment, at least 99 percent of the contamination would have evaporated within a few hours. Therefore, external building wash down may not be necessary. As a result, vapor concentrations will be high but should not last long. If liquid contamination soaks into soft, porous soil (such as loose sand), evaporation is not as quick. Strong winds also increase the evaporation rate. Low temperatures during the night have a reverse effect and tend to increase the persistency of chemical and biological contamination. The sandblasting effect of sandstorms may remove contamination from surfaces facing the storm. Sunlight and high temperatures will destroy many CB agents without additional decontamination measures if time permits. Rain can help the decontamination process by washing away contamination on exposed surfaces. Rain can also hydrolyze some agents. However, runoff may contaminate the soil. For more detailed information on fixed facility decontamination procedures, types of contamination and how to decontaminate them, and decontamination of specific surfaces and materials, refer to FM 3-11.5/MCWP 3-37.3/NTTP 3-11.26/AFTTP(I) 3-2.60 and FM 3-11.4 (FM 3-4)/MCWP 3-37.2/NTTP 3-11.27/AFTTP (I) 3-2.46.

## **19. Training and Exercises**

a. Individual and joint unit decontamination training across the force ensures the readiness to fight and win should an adversary employ CBRN weapons. Training is a responsibility shared by combatant commands, Services, and a number of DOD agencies. Training and exercise programs must incorporate the principles for operations in CBRN environments and include realistic consideration of CBRN weapons effects on sustained combat operations.

b. Training opportunities exist both internally and externally and should include the following:

- Initial and sustainment training.
- Individual, collective, and unit training.
- Intraagency and interagency training.

c. Exercises provide the opportunity to interact with other units or services and federal, state, or local agencies. Exercises developed by non-DOD agencies provide an opportunity to improve military capabilities for support of homeland security operations with minimal resources. These exercises emphasize interoperability requirements and stress staff coordination. They also serve to identify shortfalls in communications or other capabilities that must be corrected.

## 20. Restriction of Movement, Isolation, and Quarantine

a. To prevent the spread of an infectious disease or contagious illness, public health authorities use different strategies. Three of these strategies are: restriction of movement (ROM), isolation, and quarantine. These are common practices in public health and aim to prevent and control exposure to potentially infected or infectious persons. These measures may be voluntarily, implemented or be a directive by public health authorities or by military commanders.

b. The three strategies differ in that ROM restricts persons to stop the spread of illness; isolation applies to persons who are known to have an illness; and quarantine applies to those who have been exposed to an illness but who may or may not become ill. During a declared public health emergency, a commander, in consultation with the public health executive officer, may exercise special powers relating to persons necessary to prevent the spread of communicable diseases. To the extent necessary for protecting or securing military property or places and associated military personnel, such special powers may also include persons other than military personnel who are present on a DOD installation or other area under DOD control. For more information, refer to DODI 5200.8.

(1) Restriction of Movement. The ROM refers to potentially infected persons and the restriction of their movement to stop the spread of that illness. Restrictions of movement may be implemented to prevent the spread of communicable diseases. In the case of military personnel, restrictions of movement, including isolation or quarantine, or any other measure necessary to prevent or limit transmitting a communicable disease may be implemented. In the case of persons other than military personnel, restrictions of movement may include limiting ingress and egress to, from, or on a military installation.

(2) Isolation. Isolation refers to the separation of persons who have a specific infectious illness from a healthy population. Isolation allows for the target delivery of specialized medical care to people who are ill, while protecting healthy people from getting sick. Infected people in isolation may be cared for in their homes, in hospitals, or in designated MTFs. Isolation is a standard procedure used in hospitals for patients with TB and certain other infectious diseases. Although in most cases, isolation is voluntary; however, many levels of government (federal, state, and local) especially the DOD have basic authority to compel isolation of sick people to protect the public.

(3) Quarantine. Quarantine refers to the separation and ROM of persons who, while not yet ill and have not shown signs and symptoms of the disease, have been exposed to an infectious agent and therefore may become infectious. Quarantine involves the confinement and active, continued health surveillance of an individual who is suspected of having been exposed to an infectious agent until determined that they are free of infection. Quarantine is medically very effective in protecting the public from disease.

(4) Protective Sequestration. Protective sequestration is a form of *reverse isolation* where uninfected Service members are isolated from the infected population or contaminated environment as a tactical or strategic reserve. Protective sequestration is a measure or option that commanders may use after a CBRN incident.

## 21. Worried Well

a. During a CBRN incident, many people are fearful of having been exposed to a CB warfare agent, even though they are either at very low risk or have tested negative for exposure. The common term used to describe people in this situation is *worried well*. This term generally refers to people who are worried (or convinced) that they have been exposed



to a CB agent, even though they are physically well and do not actually display the signs and symptoms of being exposed to a CB agent.

b. The actual cause is usually psychological, rather than medical among *worried well* people. Psychological problems commonly associated with *worried well* people include—

- Clinical depression.
- Severe anxiety disorders.
- Phobias.
- Obsessive-compulsive disorder.
- Other psychological disorders.

c. These psychological problems can only be diagnosed by a qualified behavioral health (BH) professional such as a BH counselor, a psychologist, or a psychiatrist. When a Service member presents himself to an MTF during a CBRN incident, he should be considered at some risk of exposure until he has been tested and examined by the above-mentioned BH professionals and can they be ruled out and called *worried well*. It is only through examination, testing, and history taking that the potential of being exposed to a CB agent can be discounted.

d. During the sarin gas release in the Tokyo subway system in 1995, the hospitals were presented with over 5,500 possible casualties. Only 1,000 were casualties related to the attack and only 12 deaths were related to this catastrophe. The total number of those who presented themselves to the hospital with complaints of postexposure symptoms exceeded the number who did require medical treatment caused by exposure.

e. The importance of the appropriate response to the *worried well* during a CBRN incident has to be considered. Medical personnel and BH treatment providers must be prepared to provide some level of treatment for individuals showing acute or transient emotional and behavioral signs and symptoms. While the acutely ill patients have priority of treatment, attention must also be paid to the *worried well* and others affected psychologically. If the *worried well* personnel are not cared for immediately, the command or community will experience BH consequences, even long after the CBRN crisis is over.

**This page intentionally left blank.**

## Chapter IV PATIENT MOVEMENT

### 1. General

a. Patient movement in combat areas is normally a Service responsibility using organic assets (personnel, ground vehicles, watercraft, and aircraft). The CCDR, with the advice of the JFS, is responsible for moving casualties within the theater and deciding the extent to which evacuation assets will be committed to contaminated areas. The Commander, USTRANSCOM is the DOD single manager for intertheater patient movement. The CCDRs are responsible for intratheater patient movement. The primary mission of the DOD patient movement system is to safely transport US military casualties from the combat zone to fixed MTFs and/or to Role 3 MTFs rearward in or out of the combat zone, as required.

b. Medical evacuation may be conducted in conjunction with combat operations, troop movements, or logistics movements within an AO. The JFCs should integrate and coordinate the use of evacuation resources towards the common purpose of reducing mortality while maintaining medical treatment, in support of the theater, and subordinate joint force objectives. Thus, it is critical that each Service component properly plan to operate its portion of the overall patient movement system.

c. The techniques and procedures that govern medical evacuation operations in full spectrum operations almost universally apply when operating in a CBRN environment however, casualties contaminated with CBRN agents will normally be decontaminated prior to evacuation. Decontamination and processing procedures must be in place to prevent the spread of CBRN agents and to ensure the appropriate protection for casualties, crew, and evacuation asset.

d. A CBRN incident also has the potential to instantaneously produce a very large number of casualties, severely impacting the entire medical treatment and evacuation systems. The resulting casualties can be at seriously ill or injured and may require ventilator support.

### 2. Medical Evacuation in a Chemical, Biological, Radiological, and Nuclear Environment

a. A CBRN environment forces the unit leadership to consider to what extent they will commit medical evacuation assets to the contaminated area. If the unit or task force is operating in a contaminated area, most of or the entire number of organic medical evacuation assets will operate there. However, efforts should be made to keep some ambulances free of contamination. For conventional medical evacuation operations see JP 4-02 and FM 4-02.2.

#### b. Tactical and Operational Medical Evacuation.

(1) Once the use of CBRN weapons has been confirmed and areas of contamination identified, subordinate commanders must decide the extent to which they will commit evacuation assets not already contaminated during the attack. Depending on the situation, there may already be adequate numbers of vehicles, watercraft, and aircraft operating within the affected areas to transport the number of casualties sustained. Full use of these assets should be made while keeping the safety and operational exposure of the personnel operating them in mind. These platforms (if not otherwise damaged) can respond

relatively quickly to transport the wounded to designated areas where they can undergo patient decontamination and receive medical treatment.

(2) On the modern battlefield, land forces have three basic modes of evacuating patients (personnel [litter bearers], ground vehicles, and aircraft). Watercrafts may also be used to conduct patient evacuation for waterborne forces (see MCRP 4-11.1E).

(3) Using litter bearers to carry the patients involves a great deal of stress. Cumbersome MOPP gear, added to climate, increased workload, and the fatigue of battle will greatly reduce personnel effectiveness. If personnel must enter a radiologically contaminated area, an operational exposure guide (OEG) record must be established. In addition, either a thermoluminescent dosimeter or electronic radiation dosimeter (such as the AN/UDR-13) should be worn. Radiation exposure records are maintained by the CBRN officer/NCO and made available to the commander, staff, and command surgeon. The exposure is entered into the individual's medical record, (refer to FM 4-02.4 for information on maintenance of field medical records). Based on the OEG, the commander and leaders will decide which medical evacuation assets will be sent into the contaminated area.

(4) Every effort is made to limit the number of ground medical evacuation assets that are contaminated. Medical evacuation considerations include—

(a) A number of ambulances will become contaminated in the course of battle. Optimize the use of resources; use those already contaminated (medical or nonmedical [CASEVAC]) before employing uncontaminated resources.

(b) Use ground ambulances instead of air ambulances in contaminated areas; they are more plentiful, are easier to decontaminate, and are easier to replace.

(c) Use ground vehicles to cross the line separating clean and contaminated areas. The ground ambulance proceeds to an MTF with a PDS; the patient is decontaminated and treated. If further medical evacuation is required, a clean ground or air ambulance is used. The routes used by ground vehicles to cross between contaminated and clean areas are considered dirty routes and should not be crossed by clean vehicles, if the mission permits. Consider the effects of wind and time upon the contaminants; some agents will remain in the area for extended periods of time.

(5) The relative positions of the contaminated area, forward line of troops, and threat air defense systems will determine where rotary wings or aircraft may be used in the medical evacuation process. One or more rotary-wing or aircraft may be restricted to contaminated areas.

(a) Once a rotary-wing or aircraft has entered a contaminated area, it is highly unlikely that it can be spared long enough to undergo thorough decontamination or DED. However, spot or operational decontamination should be performed to the greatest extent possible. This will depend upon the contaminant, the operating tempo (OPTEMPO), and the resources available. Normally, contaminated vehicles (air, water, and ground) will be confined to dirty environments. See FM 3-11.5/MCWP 3-37.3/NTTP 3-11.26/AFTTP(I) 3-2.60 for details on decontamination procedures.

(b) Keep the rotary-wing rotorwash and the aircraft propeller blast in mind when evacuating patients, especially in a contaminated environment. The intense rotorwash and propeller blast will disturb the contaminants and further aggravate the condition. The aircraft must be allowed to land and reduce to flat pitch before patients are brought near it. Additionally, a rotary-wing aircraft must not land too close to a PDS (especially upwind) because any trace of contaminants in the rotorwash will compromise the decontamination procedure.

(6) Immediate or spot decontamination of vehicles, watercraft, and aircraft is accomplished to minimize crew exposure. Spot decontamination is an immediate decontamination technique that will normally be performed on aircraft that have been recovered and will be quickly turned around for continued flight operations. Units must include decontamination procedures in their SOP. For additional information on DED, refer to FM 3-11.5/MCWP/3-37.3/NTTP 3-11.26/AFTTP(I) 3-2.60.

(7) Evacuation of patients must continue, even in a CBRN environment. The HSS leader must recognize the constraints CBRN places on operations, then plan and train to overcome these deficiencies.

(8) To minimize the spread of contamination inside the ground ambulance, watercraft, or aircraft, plastic sheeting should be placed under the litter to catch any contaminant that drips off the patient or litter. The plastic sheeting can be removed with the patient, removing any contamination with it. When plastic sheeting is not available, placing a blanket under the litter will reduce the amount of agent that makes contact with the inside of the ground ambulance, watercraft, or aircraft.

---

Note: The key to mission success is detailed preplanning. A FHP and HSS plan must be prepared for each support mission. Ensure that the FHP and HSS plan is in concert with the tactical plan. Use the plan as a starting point and improve on it while providing HSS.

---

(9) Patient protection during evacuation must be maintained. Patients that have been decontaminated at the MTF PDS will have had their MOPP ensemble removed. The forward deployed MTFs will not have replacement MOPP ensembles for the patients. These patients must be placed in a PPW before they are removed from the clean treatment area for evacuation. The PPW provides the same level of protection as the MOPP ensemble. The patient does not have to wear a protective mask when inside the PPW. The patient is placed inside the PPW that is on a litter. The PPW has a battery-operated blower that can provide a reduction of the body heat load and reduce the carbon dioxide level within the PPW. The PPW will provide protection for the patient for up to 6 hours and is a onetime use item. The blower is reusable and is a decontaminable PMI. Refer to FM 4-02.1 for a discussion of PMI.

**WARNING**

**Do not place contaminated patients in the PPW. This will cause gas chamber effects on patient. It is for use with uncontaminated/decontaminated patients only.**

c. Strategic Medical Evacuation.

(1) Both intertheater and intratheater, medical evacuation by USAF aircraft will be severely limited until decontamination has occurred. Aerial flights from contaminated areas into uncontaminated airspace and destinations may be impossible for extended periods of time; some nations will not allow patients from contaminated areas to travel through or over their country. Therefore, patient holding onsite (or in theater) for an extended period of time must be anticipated.

(2) If a fixed-wing aircraft becomes contaminated as a result of transporting contaminated casualties that aircraft would have to divert to a remote or designated site for decontamination after its mission. This will place the aircraft out of service for an extended

period of time. Therefore, contaminated casualties will require special validation from the Patient Movement Requirements Center for aeromedical evacuation by both the theater CCDR and the Commander, USTRANSCOM.

(3) If the decision is made to move CBRN contaminated casualties using AE resources, the AE crew will need to be in protective posture. When in protective gear, AE crews are severely limited in their ability to assess the casualty and problems can exist in trying to palpate, auscultate, or visually examine the casualty.

(4) Casualties exposed to CW agents or TIM agents must be decontaminated prior to AE. Once casualties are thoroughly decontaminated, further AE decisions are based on actual or suspected clinical diagnosis and casualty medical condition. Commanders, AE elements, and medical personnel should apply specific contamination control measures.

(5) Normally, BW casualties may be evacuated using standard precautions. However, casualties suspected of having highly contagious diseases (such as smallpox and pneumonic plague) will not be placed on AE aircraft unless placed in high-level containment such as patient isolation unit (PIU) or aircraft transport isolator (ATI). The PIU or ATI is a biological agent controlled containment for casualty isolation with treatment access and is transportable by land and air. Ideally, the USAMRIID US Army Aeromedical Isolation Team (AIT) should escort these individuals under high-level containment. This team does not have the resources for mass patient transport.

(6) If the theater situation dictates a mass patient movement with individuals who have infectious diseases, validation for movement must be obtained through the Patient Movement Requirements Center from both the theater combatant commander, and the USTRANSCOM commander. Evacuating contaminated casualties and/or potentially contaminated casualties requires approval of the destination country, overflight privileges, and approval of any country where the aircraft will land for servicing or where casualties will remain overnight. Close coordination between the CCDR and the DOS is required for such movement.

### **3. Medical Air Evacuation Under High Level Biosafety Containment**

a. Air evacuation of patients with potentially lethal, contagious infections poses unique challenges and risks to air crews and medical personnel. Evacuation of such patients is relevant to military contingency operations because troops may be placed at risk for hemorrhagic fevers and other infections during deployment to tropical environments or by adversaries' use of BW agents.

b. Evacuation of patients to the USAMRIID would afford the immediate availability of biosafety Level (BSL) 4 laboratories (designed for the study of pathogens requiring maximum biological containment for laboratory safety) and facilitate rapid diagnosis of diseases due to pathogens posing extraordinary laboratory safety hazards. To safely evacuate a limited number of patients to the containment-care suite and provide medical care while minimizing the risk for transmission to air crews, caregivers, and civilians, USAMRIID maintains an aeromedical isolation team.

c. Maximum biological containment is designed to prevent transmission of highly hazardous pathogens and is accomplished in two steps. First, the health-care worker wears an Occupational Safety and Health Administration (OSHA)-approved protection gear for working in environments with respiratory hazards; second, the patient is isolated within a sealed container under negative air pressure maintained by a battery-powered high efficiency particulate air (HEPA)-filtered ventilation system providing five air exchanges per

hour. Two isolators are used, the stretcher isolator, a lightweight unit for initial patient retrieval and the ATI, a larger unit for definitive transport and in-flight care.

d. Portable isolation units have been used to treat inpatients with suspected Ebola, Lassa, and Marburg hemorrhagic fevers. The transport isolators, the only available technical means of reliably maintaining airborne isolation in a military transport aircraft, have been successfully used for the AE of patients with suspected Ebola fever and suspected and proven Lassa fever.

#### **4. Aeromedical Evacuation Process**

a. The patient must be evaluated and stabilized before transport to ensure survival en route. Only patients likely to survive transport would be evacuated. The physiologic effects of altitude, effect of confinement on patient-care delivery, and psychologic effect of confinement within the isolator must be considered. Mechanical ventilation cannot be provided in the ATI and suction capabilities are limited; therefore, acute respiratory failure and presence of gas trapped within closed body cavities that may pressurize at high altitudes (for example, pneumothorax or intestinal gas due to ileus or bowel obstruction) contraindicate evacuation. Evacuation of patients with conditions requiring special in-flight management, for example, hemodynamic fluctuations and severe anemia, may also be contraindicated.

b. The patient is placed inside the stretcher isolator and carried to a transfer point near the aircraft. There the stretcher isolator and team members' equipment is decontaminated with a quaternary ammonium compound. The ATI is maintained under negative air pressure until decontaminated at USAMRIID. Equipment is removed, placed in bags, and returned to USAMRIID for decontamination of respirators and radios and disposal or decontamination of coveralls.

c. The patient is transported on standard military transport aircraft (C-130, C-5, C-17, KC-135, and CH-47), which maintain an internal cabin atmosphere equivalent to approximately 8,000 feet above sea level while at altitude (26,000 feet to 35,000 feet). This level of air pressure is considered adequate to protect commercial airline passengers and results in an arterial blood hemoglobin oxygen saturation of approximately 90 percent in healthy persons.

d. Design features of the ATI that facilitate in-flight care include its larger size, additional glove ports, two half-suits, cones at the base of the envelope for introducing wires and tubing, sleeves for IV therapy, and large pockets for placing waste supplies. Diagnosis and therapy, which can be delivered in the ATI, include monitoring cardiac function, blood pressure, and oxygen saturation of the blood; providing oxygen supplementation, IV therapy, and phlebotomy; and determining hemoglobin and hematocrit levels and serum electrolytes (by using a portable handheld laboratory analyzer). Because the use of glove ports limits manual dexterity, team members practice these skills on each other during on-ground and in-flight training exercises. To minimize the risk of puncturing the isolator, no glass bottles or instruments with rough or sharp edges are used. Phlebotomy is minimized and a needleless IV system is used.

e. After arriving at USAMRIID, the patient is transferred from the ATI into the containment-care suite through a plastic sleeve connected to a port on an outside wall.

## 5. Patient Isolation Unit

a. Recent developments have driven concern regarding the isolation and transport of contagious patients aboard AE flights. First, while *treat in place* is the primary means of caring for contagious patients, recent theater evacuation policy changes permitted the evacuation of patients on AE missions that resulted in the possible exposure of the aircraft and crew to contagious pathogens. Second, the change from dedicated AE aircraft to the use of opportune airlift means the contamination of mobility aircraft significantly impacts the overall air mobility mission because that aircraft will be rendered unavailable for missions until decontaminated. The decontamination method for aircraft exposed to contagious pathogens has not been developed. Third, the emergence of possible terrorist use of biological pathogens leads to a higher probability of US forces exposure. Fourth, the emergence of new infectious diseases in the civilian sector, such as severe acute respiratory syndrome (SARS) and avian flu, increases the probability of military personnel, their dependents, or government civilian personnel contracting these diseases and thus requiring AE to a definitive MTF. The challenge is to transport these patients without experiencing adverse consequences.

b. The mission of AE is fixed-wing movement of patients requiring supervision and care by AE personnel to locations offering appropriate levels of medical care. The AE system can operate as far forward as fixed-wing aircraft are able to conduct secure operations. The AE is a Total Force system prepared to support the full spectrum of military and humanitarian operations at anytime, and anywhere. Aeromedical evacuation crew members (AECMs) are prepared to move patients on any available fixed-wing, mobility airlift platform. The PIU allows AECMs to take advantage of transiting platforms and enhances mobility airlift platforms capable of performing the AE mission.

c. Contaminated or contagious patients may come from many sources. Events may be the result of a BW attack, terrorist attack, or from exposure to an existing or emerging infectious disease. There may be political pressures to transport these casualties to CONUS for treatment or pressure to leave them OCONUS to avoid the spread of the infection to the general population. Diplomatic efforts may be undertaken to permit AE flights to fly in foreign air space or land for emergency repairs. The decision to move contagious casualties will be directed through USTRANSCOM and the theater CDR.

d. The PIU provides a capability to move a small number of highly contagious patients through the AE system. In most situations, it is recommended that the necessary medical resources be moved to the event location (*treat in place*) rather than moving the contagious patient. The PIU will enhance force protection by providing medical personnel the capability to transport contagious patients without fear of contamination to caregivers, other patients, passengers, and transport vehicles. The PIU will be light enough for use in the field and rugged enough to support movement through the DOD patient movement system. Evacuation of potentially contagious patients requires close coordination with multiple agencies both military and civilian (such as the DOS, Centers for Disease Control and Prevention [CDC], USAMRIID). The USAF Initial procurement is projected at 20 units; IOC was in fiscal year (FY) 07 and fully operational capable expected in FY 09. The PIU will be strategically placed at locations based on risk vulnerability to a pathological event and is not intended to be included in the PMI inventory.

e. The procurement of more PIUs does not mean that more biologically contaminated/contagious patients can or will be transported to MTFs. Factors such as the theater CBRN evacuation policy, the AE crew's PIU level of training, and most importantly, the ability of a destination facility to accept them have to be considered.



- f. The desired operational effects and goals of PIUs are to—
- Ensure no additional infections occur as a result of transporting contagious patients.
  - Provide quality medical care to the contagious patients while they are isolated.
  - Ensure the level of isolation is consistent with medical practices and disease severity.
  - Minimize disruption to the aircraft's primary mission or AE patient movement system during patient transport.
  - Maximize the comfort of the patient within the constraints of the AE environment.

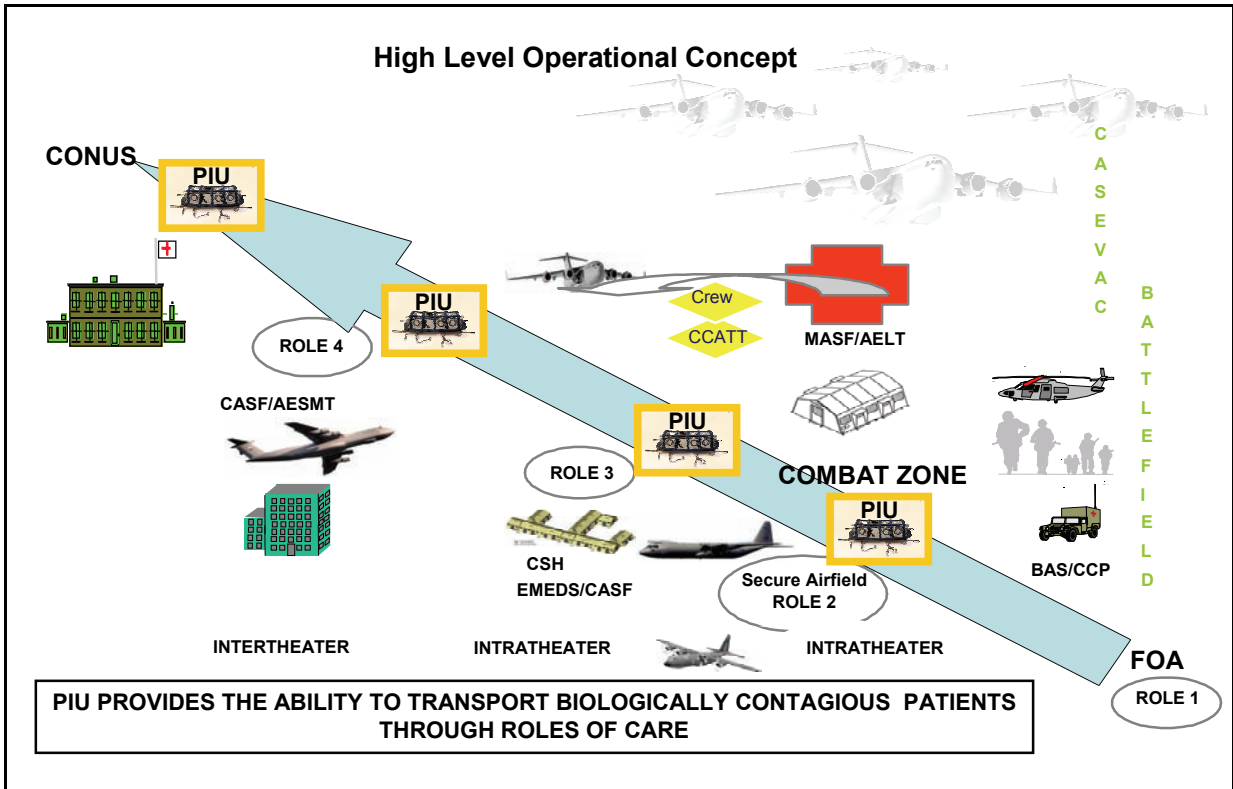

Figure IV-1. Patient Isolation Unit Roles of Care Operational Concept

g. Table IV-1 lists some of the contagious diseases that require patient isolation during AE.

**Table IV-1. Contagious Diseases**

- Arenavirus infection
  - Argentine hemorrhagic fever (Junin virus)
  - Bolivian hemorrhagic fever (Machupo virus)
  - Brazilian hemorrhagic fever (Sabia virus)
  - Lassa fever
  - Venezuelan hemorrhagic fever (Guanarito virus)
- Avian flu
- Bunyavirus infection
  - Congo-Crimean hemorrhagic fever
- Filovirus infection
  - Ebola
  - Marburg
- Orthopoxvirus infection
  - Monkeypox
  - Variola
- Tuberculosis
- Pneumonic plague until sputum cultures are negative
- Any unknown virulent communicable disease pending diagnosis
- Suspected BW-caused infection

## Chapter V

# PATIENT DECONTAMINATION

### 1. General

a. The purpose of this chapter is to describe patient decontamination from initial exposure on the battlefield to the patient's admission to the MTF whether on land or on the sea. This chapter addresses non-Service-specific technical and operational principles, techniques, procedures, methods, equipment, and issues associated with the performance of patient decontamination after a CBRN incident. Patient decontamination must be in place at the MTFs at all roles of medical care.

(1) The principles and processes of patient decontamination are generally identical throughout the Services, with some variances based on METT-TC. Common aspects will be emphasized in this chapter. Suggested patient decontamination procedures are noted in this chapter but are not Service-specific. They are based on the available equipment as follows—

- (a) Patient decontamination with minimal equipment (for example, litter stands, buckets).
- (b) Patient decontamination using plumbed tentage, showers, and roller systems.
- (c) Patient decontamination on a water vessel.

(2) Contaminated patients potentially create increased hazard to first responders, CASEVAC/medical evacuation teams, medical personnel, and medical facilities. The three key purposes of patient decontamination are to—

- (a) Protect the MTF staff and material.
- (b) Protect evacuation team and equipment along the evacuation route.
- (c) Remove contamination from the patient to reduce agent exposure.

(3) In some CBRN scenarios, little or no decontamination may be necessary to process a patient—especially if lifesaving measures are time critical. The extent to which a patient requires decontamination is dependant on various factors—

- (a) Agent (chemical, biological, radiological) and its characteristics (for example, persistent versus relatively nonstable agents, overall severity of effects).
- (b) Conditions of the release and resulting exposure (for example, liquid versus vapor only).

b. Patient decontamination is different from troop or personnel decontamination as patients going through decontamination also have medical conditions that must be managed. With the exception of the Air Force and some ship-based units, which deploy trained medical decontamination teams composed of medical personnel, the patient decontamination process is carried out by nonmedical augmentees who are supervised by trained medical personnel. These nonmedical augmentees are designated by the supported unit commander.

c. Patients who present themselves for decontamination may suffer from the effects of exposure to a CBRN agent, or TIM. They can also have conventional wounds; psychological stress reactions; combat and operational stress reactions (COSR); worried well; and malingerers; or any combination of these. In addition, patients may have heat injuries induced by extended time spent in MOPP Level 4. It is important to quickly determine whether there is potential for residual contamination on a patient or in bodily fluids for certain infectious biological agent that may pose a continued hazard to the patient or a cross-contamination to

responders/MTF personnel. While not all CBRN agents/scenarios require decontamination (see Table V-1), when in doubt utilize most protective personal protection and decontamination actions feasible.

d. The protective ensemble is worn in a military combat situation where there is an expected CBRN threat. Casualties wearing the ensemble are protected from warfare agents in either dry solid, liquid, vapor, and gas form. Removing a contaminated uniform or protective ensemble will remove approximately 95 percent or more of the agent. Foreign objects in wounds (for example, shrapnel) or torn ensemble will cause a breach in the protective ensemble, allowing agents to reach and contaminate the tissues. Individuals not wearing a protective ensemble will have little or no protection when exposed to an agent. Regular clothing can absorb liquid agent, allowing it to touch the skin. Fabric weave can also hold chemical vapors or aerosolized biological agents. In general however, external clothing removal and rinsing of exposed skin and hair with water or soap and water is generally considered adequate decontamination for most chemical vapor only exposures or biological aerosols. Refer to Tables V-1 and V-2.

e. While these guidelines apply specifically to the wartime battlefield scenario, the same principles and techniques can be readily applied to a homeland, garrison/installation, or civilian setting.

### **WARNING**

**Cross-contamination of patients by decontamination personnel can result in further injury to the patient. Decontamination personnel handling patients must not have been involved in decontamination operations or be thoroughly decontaminated prior to handling patients. Bleach requires contact time with agent for complete neutralization dependent on the ambient temperature. Ensure decontamination personnel have waited a sufficient amount of time before handling patients to allow for this contact time to neutralize agent.**

## **2. Levels of Decontamination**

a. General. The levels of decontamination used for patients are similar to those levels used for the decontamination of personnel and equipment. There are three levels of patient decontamination in the conflict area—

- Immediate (gross) decontamination.
- Operational decontamination.
- Thorough decontamination.

b. Immediate (gross) Decontamination. Patient decontamination begins at the time of exposure. To significantly reduce agent absorption and the damaging effects of an agent, decontamination should be performed within the first two minutes after exposure, though later decontamination still has benefits. Decontamination also reduces the possibility of cross-contamination from the exposed Service member's garments to equipment or other persons. The contaminated Service member performs immediate (gross) personal decontamination using the appropriate decontaminant. Contaminated areas on the protective ensemble and exposed intact skin are decontaminated. If Service members are not able to decontaminate themselves due to injury or incapacitation then a buddy performs this function.

c. Operational Decontamination. This is performed at the unit level to reduce contamination on designated in-theater evacuation assets. It is done prior to loading the patient on a vehicle for evacuation within the tactical area. The patient remains in protective ensemble and mask. Any liquid or solid hazard on the ensemble and skin are decontaminated so that the spread of contamination within the evacuation vehicle is minimized.

d. Thorough Decontamination. This is the final level of patient decontamination. It generally involves at least removal of all outer garments and removal of residual agents on skin or in hair. Table V-1 provides some guidance's to what degree of decontamination may be necessary to achieve thorough decontamination for different types and forms of agents. Equipment and technical decontamination where a fourth level of decontamination called clearance decontamination is doctrinally described FM 3-11.5/MCWP 3-37.3/NTTP 3-11.26/AFTTP(I) 3-2.60 for verification that all residual hazard has been mitigated to levels acceptable for unprotected personnel. While it is critical to prevent exposure to medical staff, excessive decontamination procedures should be avoided to prevent delays to medical treatment. This process ensures that the patient has been properly decontaminated and all necessary records regarding decontamination, monitoring results, type and duration of exposure and location of incident are properly recorded to facilitate future medical surveillance and ensure the safety of all personnel after the patient's release or transfer to a medical facility location outside the CBRN environment. This level of decontamination is performed by augmentees who are closely supervised by medical personnel or, in the Air Force and some Navy ship-based units, by trained decontamination teams of medical personnel. Much of this chapter is devoted to discussing various ways to conduct patient thorough decontamination.

### **3. The Importance of Early Contaminant Removal and Medical Monitoring of Patients**

a. Many liquid chemical agents (such as liquid nerve, blister, and cyanide) can sequester in the skin if not promptly removed from the patient through patient decontamination. In liquid form the agents take time to work their way through the skin and into the blood stream to cause systemic effects. The systemic effects from liquid chemical agent on the skin or solid agent on sweaty skin may not be seen for minutes to hours after exposure depending on the toxicity of the agent and amount of agent contacted. Even after patient decontamination, a patient exposed to a dry or liquid agent may continue to show worsening symptoms. With these types of exposures, patients must continue to be treated after decontamination.

b. All patients need close medical monitoring and medical treatment before, during, and after patient decontamination at the medical facility.

c. Decontamination of HR is a mortuary affairs responsibility as described by JP 4-06. Medical and or PVNTMED assets may need to support the process by assisting with the assessment of residual hazard and determining when residual CBRN risks have been adequately mitigated. Decontamination of HR while much less time critical than that of patients is still a real-time process that can be facilitated by proper assessment of the potential residual hazard (contamination). Human remains, as with patients, inherently pose some level of disease risk from potential bloodborne pathogens for which established standard or universal precautions and PPE are designed to mitigate. This does not mean they are *contaminated*. Human remains are considered *contaminated* if a residual CBRN agent is present and poses a known or plausible hazard to personnel beyond those addressed by routine precautions used to handle HR. For many CBRN agents and scenarios, it may not be necessary to classify remains as contaminated. The determination of whether HR are CBRN contaminated and pose a risk greater than that posed by normally anticipated bloodborne pathogens will depend on many

factors to include the type of agent and its characteristics and the conditions of the release and its environment. Some general considerations are provided below:

(1) Biological hazards. Regardless of CBRN conditions, all HRs inherently have the potential to release transmissible disease agents (for example, bloodborne pathogens) that have been internalized and which then may be released in a viable form in blood, body fluids, feces, or gastrointestinal contents. Established procedures and PPE are designed to protect against such risks for common and endemic diseases. For more information, refer to TG 195. These same procedures will protect against similar risks associated with many less common biological agents including some of those identified as potential warfare agents. However, additional safety precautions and PPE for potentially released internal fluids are especially necessary for certain highly infectious, easily transmissible pathogens for which effective treatment and preventive measures are not usually available (such as certain hemorrhagic fevers [Ebola, Marburg, and so forth]) as well as variola virus (smallpox), and *Yersinia pestis* (pneumonic plague). For a complete list of such agents refer to the WHO Risk Group IV agents. Special handling and additional precautions are also advised for certain other agents such as CDC's select (Category A) agents that include *Bacillus anthracis* (inhalational anthrax), *Burkholderia mallei* (glanders), *Yersinia pestis* (pneumonic plague), *Francisella tularensis* (tularemia), and *Variola virus* (smallpox), as well as the WHO Risk Group IV agents. It is noted that for most biological pathogens the risk is due to internal contamination source that cannot be mitigated/eliminated through decontamination. However, certain CBRN scenarios that involve the intentional release of a persistent aerosolized biological agent may have the added consideration of the external biological hazard on clothing or skin. This may be a concern particularly if there is concern of reaerosolization—for example, in the event of an aerosol release of anthrax spores or toxins.

(2) Chemical hazards. The hazards associated with chemical releases are primarily associated with the potential for residual *external* contamination (for example, on clothing, skin, and hair). This is primarily a concern for persistent chemical agents (such as sulfur mustard and nerve agent [VX]), which have low volatility and can remain present at hazardous levels for several hours or days). Nonpersistent chemicals including TICs of military concern (for example, chlorine gas) as well as highly volatile CW agents such as sarin, are typically released as a vapor and dissipate/volatilize quickly so the hazard is naturally degraded/mitigated to negligible levels. While mitigation of even nonpersistent warfare agents are generally processed through decontamination and verified through monitoring (for example, ICAM), decontamination and monitoring of HR from a TIC incident is not necessary.

(3) Radiological hazards. Determination of the degree of contamination risk, appropriate personal protective measures, and other control measures depend on radiation type, dose and dose rates. Internal radiation exposure (generally caused by inhalation or ingestion) will likely pose little health risk to persons exposed to the remains. External contamination can be mitigated by removing clothing and washing the skin.

**Table V-1. General Recommended Decontamination Actions by Type and Category of Agent**

Minimal decon for dusty/solid agents of any type (chemical, biological, radiological)		Carefully cut off and roll back outergarments to contain dust particles. May need to remove inner garments (upwind) if covered in solid dusty agent. HEPA vacuum can be used on garments or garments misted with water prior to garment removal to minimize reaerosolization. Wet towels may be laid over garments first to minimize reaerosolization during misting.	
<b>Additional decontamination guidance by hazard type:</b>			
<b>Chemical</b>		<b>Biological</b>	<b>Nuclear/Radiological</b>
Liquid CW agents	<ul style="list-style-type: none"> <li>- Remove all clothing and equipment.</li> <li>- Physically remove mass agent from skin, mask.</li> <li>- Thoroughly wash with soap and water or use 0.5 percent hypochlorite solution.</li> <li>- Air monitoring (for example, ICAM).</li> </ul>	<ul style="list-style-type: none"> <li>- Outer wear removal.</li> <li>- Thorough soap and water rinse.</li> </ul> <p><i>NOTE 1:</i> No monitoring equipment is available to "clear."</p> <p><i>NOTE 2:</i> The external decon measures will not address hazards associated with <i>internal</i> sources such as bodily fluids and so forth that for certain highly infectious and communicable (transmissible) disease organisms (for example, Ebola, Marburg, and various hemorrhagic fevers) are of greatest concern and must be managed appropriately.</p>	<ul style="list-style-type: none"> <li>- Minimize reaerosolization.</li> <li>- Dry brushing/shaking.</li> </ul> <p><i>Additional precautions if feasible/time allows:</i></p> <ul style="list-style-type: none"> <li>- Soap and water rinse.</li> </ul>
Vapor persistent agents (for example, HD, VX)  and  Liquid TICs (for example, liquid chlorine)	<ul style="list-style-type: none"> <li>- Remove all clothing and equipment.</li> <li>- Wash with soap and water or water rinse will do.</li> </ul> <p><i>Additional precautions for thorough decon:</i></p> <ul style="list-style-type: none"> <li>- Air monitoring (for example, ICAM) for CW agent.</li> </ul>		
Vapor nonpersistent agents (sarin)	<ul style="list-style-type: none"> <li>- Remove all clothing and equipment.</li> </ul> <p><i>Additional precautions for thorough decon:</i></p> <ul style="list-style-type: none"> <li>- Wash with soap and water or water rinse hair and exposed skin.</li> <li>- Air monitoring (for example, ICAM) for CW agent.</li> </ul>		
Vapor TICs (for example, chlorine gas)	<ul style="list-style-type: none"> <li>- <i>No decon needed.</i></li> </ul> <p><i>Additional precautions for thorough decon:</i></p> <ul style="list-style-type: none"> <li>- Outer wear removal.</li> <li>- Wash with soap and water or water rinse hair and exposed skin.</li> </ul>		
<b>NOTE:</b> Wastewater from decontamination that involves solution (soap and water; water; 0.5 percent hypochlorite solution) should be collected and disposed of properly.			

#### 4. Zones of Contamination

a. In interagency operations, a contaminated area is divided into zones of contamination modified following the guidelines prescribed in the Environmental Protection Agency (EPA) Standard Operating Safety Guidelines and the OSHA Act (29 Code of Federal Regulations [CFR] 1910.120). To more effectively manage the contaminated area, a variety of control lines and points are designated depending upon the level of contamination. These same areas hold true in the battlefield.

b. Hot Zone. The hot zone is also called the *isolation zone* (Emergency Response Guidebook 2008) and *exclusion zone* (OSHA's hazardous waste operations and emergency response course). This is the area that is directly contaminated by CBRN agents. In combat, this is the contaminated battlefield or TIM release. Casualties usually undergo immediate (gross) decontamination in the hot zone or near it. The MOPP Level 4 posture will provide protection against warfare agents (for example, chlorine, phosgene, mustard, nerve agents, and cyanide) in an open battlefield environment where the vapor is dispersed by the wind currents. The military protective ensemble is not intended for oxygen-depleted areas or for long term use in confined spaces with high concentrations of TIC. In a confined space or where nonbattlefield TIC (for example, ammonia or carbon monoxide) is used, a SCBA, or special filters that will protect against the specific TIC must be used. Other names for the hot zone include the contaminated area, predecontamination zone, hazard area, dirty area, area of release, or red zone. Refer to Figure V-1 below.

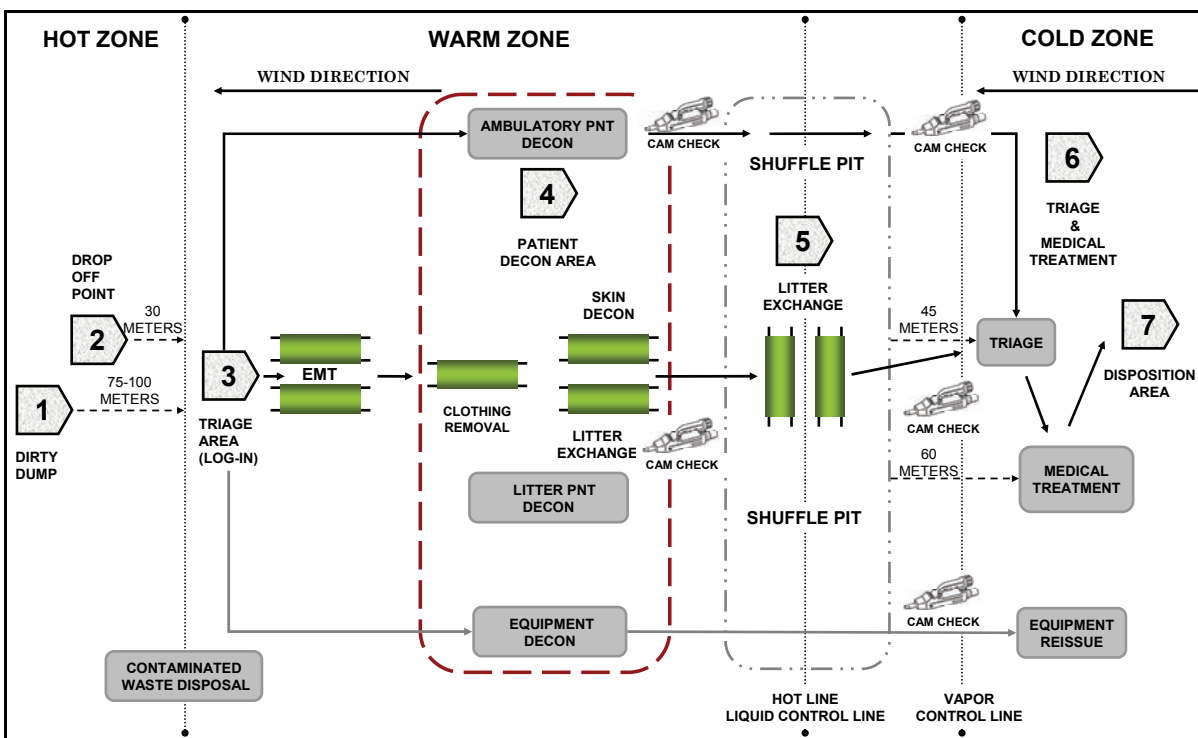

Figure V-1. Patient Decontamination Site Layout

c. Warm Zone. This is an area where low levels of dry, liquid, and vapor contamination can be expected once contaminated individuals enter this area. The contamination hazard is essentially the agent that remains on the patients that are brought into this zone (for example, the primary hazard comes from liquid or dry agent on clothing or the off gassing of vapors from liquid contaminated garments and equipment). While the direct hazards to workers is much



reduced compared to those working in the hot zone, the protective ensemble must be worn by decontamination team members as vapors and particles, even in small amounts, can pose a hazard to those working directly with the patients. The warm zone is located outside of the hot zone. In this zone, immediate (gross), patient operational, and patient thorough decontamination take place upwind of the hot zone incident location. The PDS is initially set up in an area free of contamination. This area becomes part of the warm zone once contaminated casualties begin to arrive. This zone includes control points in and out of the patient decontamination area so that contamination spread is controlled. Protective ensemble at MOPP Level 4 or OSHA Level C provides adequate protection in the warm zone. Other names for the warm zone include the contamination reduction corridor, contamination reduction zone, yellow zone, dirty zone, limited access zone, decontamination zone, decontamination corridor, or protective action zone. Refer to Figure V-1.

d. Evacuation Corridor. This corridor is within the warm zone. This includes land evacuation routes for casualties who may still be contaminated. The PDS is located in that corridor. All patients are routed through this corridor toward the MTF. In some instances patients who have only undergone immediate (gross) and patient operational decontamination may be *dirty evacuated* over or through a clean area for decontamination at a larger MTF. In this case, a separate *warm area* would be created at the vehicle drop-off point and decontamination area at the destination MTF.

e. Cold Zone. The cold zone is an area free from liquid and vapor contamination. The PDS and MTF are initially set up in the cold zone. All personnel and patient's entering this zone have been decontaminated. Protective ensemble and mask are usually not required for personnel downwind of the cold zone unless the area becomes contaminated. Standard precautions must be practiced if a patient is infected with an infectious BW agent. Other names for the cold zone include clean zone, support zone, postdecontamination zone, or green zone. Refer to Figure V-1.

## **5. Personal Protective Equipment Worn by Decontamination Operators**

a. Solid, liquid, and vapor hazards can be present in contaminated patient clothing, skin, and hair. In the PDS, hazardous CBRN agents are typically not present in the large quantities seen in the hot zone. The PDS team members assume MOPP Level 4 or OSHA Level C. Higher OSHA Levels of protection (for example, OSHA Levels A and B) are not usually indicated at the PDS as these levels place undue heat stress and strain on decontamination workers. However, personnel may still need to have them (if available) depending upon the hazards present.

b. The PDS team members using dry decontaminants, water, soap and water, or other liquid decontaminants (see Table V-2) must keep their protective ensemble dry and contamination free by wearing a butyl rubber toxicological agent protective (TAP) apron. An alternative is to wear a chemical resistant, splash protective garment. The TAP aprons and other water-resistant materials can be easily wiped down prior to performing patient lifts. Standard military protective ensemble, such as the joint service lightweight integrated suit technology (JSLIST), cannot be adequately wiped down and exposure to significant moisture will reduce its protective ability.

**Table V-2. General Chemical, Biological, Radiological, and Nuclear Decontaminants/Hazard Mitigation Techniques and Applications**

Type of Application	Type of Contaminant					
	Chemical		Biological		Nuclear/Radiological	
	Personnel: (immediate and time critical)	Surface/ Material/Area	Personnel: (not time critical)	Surface/ Material/Area	Personnel: (less time critical)	Surface/ Material/ Area
Decontaminants/Techniques						
Misting hair/clothes	minimize reaerosolization		minimize reaerosolization		minimize reaerosolization	
Physical removal	remove outer garments		remove outer garments		dry brushing/shaking	dry brushing/shaking
Water only	X	X	X			
Soap and Water	X	X	X	X	X	X
Weathering		X		X		X
Skin Decontamination	X		X			
Individual Equipment Decontamination Kit		equipment		equipment		
STB/HTH		X*		X*		
M100 SDS reactive powder		X*		X*		X
Household bleach solution (5% sodium hypochlorite)		X*		X*		
Dilute bleach solution (0.5% sodium hypochlorite)	Λ	X	Λ	X		
Absorbents (earth/soil, sawdust, ashes, rags)		for liquid decon				
Sealants/physical covers (concrete, asphalt, paint, soil)		X		X		X
Steam		§		X		X
Heat/Fire/Incineration		X		X		

\* These particularly corrosive decontaminants are specifically not to be used on certain aircraft and other equipment (a soap and water alternative is doctrinally mandated. See FM 3-11.5/MCWP 3-37.3/NTTP 3-11.26/AFTTP(I) 3-2.60 for more details.

Λ While military doctrine allows this for decon of persons, federal guidance stipulates that only water or soap and water should be used for personnel/mass decon. See *Best Practice Guidelines for CBR Mass Personnel Decontamination*, 2004.

§ Steam, as well as certain vaporized gases (ammonia, hydrogen peroxide, chlorine dioxide) may be used for the decontamination of interior buildings/heating, ventilation, and air conditioning. These can be logistically involved operations. See hazard chapters of above-mentioned guidelines for specific subject matter expert support.

c. The standard military M40, MCU2P, or new M50 mask can be worn by decontamination team members. An alternative is to wear a powered air-purifying respirator (PAPR) which has a blower motor that pulls air through the filters and into the mask hood. The circulated air blown into the mask hood keeps the decontamination team member cooler, requires no effort from the wearer to pull air through the filter, and reduces carbon dioxide buildup in the mask during heavy work. Masks of this type should be NIOSH-approved and must have an assigned protection factor of 1,000 per OSHA first receiver guidance. When working with soap and water and other liquids, the PAPR blower motor and filters can be worn under the TAP apron or to the rear of the body to keep the filters from getting wet.

d. Patient decontamination is a complex operation and labor intensive that requires special equipment to complete the mission. Some of the special equipment includes—

(1) Litters, backboards, and wheeled carriers. Only decontaminable litters, which have a mesh material that can be readily decontaminated, are to be used for transporting the patient into the PDS. If no decontaminable litters are available then plastic sheeting must be placed on canvas litters to reduce their cross-contamination by liquid or solid contaminants. Cloth litters will rapidly break down when decontaminated with 5 percent hypochlorite solution for longer periods of time. Backboards and wheeled carriers can be decontaminated with hypochlorite

solution between patients but must be rinsed thoroughly with soap and water. The use of wheeled litter carriers in the PDS makes it easy to transport patients between zones.

(2) Voice amplifiers. These should be made available for medical personnel and decontamination team members. This will allow the staff to better communicate while wearing military protective masks such as the M40. Other amplifiers are also available for the MCU2P mask and M50 mask.

(3) Radios. Radios should be made available for the decontamination team officer in charge (OIC) or noncommissioned officer in charge (NCOIC) and leaders for the ECP, drop-off point, triage area, dirty EMT area, decontamination line, hot line, and MTF. This will significantly improve communications which is vital to the smooth operation of the PDS. If handheld radios are used, they can be wrapped inside clear plastic bags and taped if contamination is a concern.

(4) Night operations. Chemical lights and 4-inch wide engineering marking or police yellow tape can be used to designate areas in the PDS. These are primarily needed for night operations. See paragraph 39 of this chapter for more information on night operations.

(5) Toxicological agent protective aprons. These aprons are essential to keep the decontamination team member's protective ensemble dry and to allow for thorough decontamination of the team member's ensemble before lifting patients. They are not needed if a waterproof protective ensemble is worn that can be adequately decontaminated between patients.

(6) Chemical agent monitor. The CAM/ICAM or other chemical detection device must be used to monitor residual contamination or determine if decontamination was successful after the patient has gone through the PDS.

## **6. Decontamination Materials**

a. Physical removal of contaminants is the primary method of decontamination for personnel. Physical removal includes washing and wiping, but never vigorous scrubbing that could abrade the skin. Skin abrasions whether through rubbing or harmful chemical reaction (for example, when 5 percent hypochlorite is mistakenly used as a decontamination solution on the skin), allow agents to move more rapidly through the skin barrier.

b. Recommended materials for patient decontamination include:

(1) Skin.

(a) M291 Skin Decontamination Kit. The SDK is a pad containing an absorbent resin. The M291 has been in the military inventory for many years. The resin pad picks up liquid agent on the skin. It is effective for immediate (gross) decontamination of chemical agent liquid on intact skin, especially in areas where water is not readily available. The SDK can be used for the decontamination of intact skin around wounds, but should not be used in wounds or on abraded skin. It is not effective for removing dry biological or radiological agents or for neutralizing them.

(b) Soap and water. This is the most preferred method. This is a low cost material that removes agents by washing them away. It is effective for removing chemical, biological, and radiological contaminants. It does not kill biological agents or neutralize radiological agents. Water runoff must be collected and treated before disposal. Liquid soap attracts the chemical agent and loosens it so that the action of the water can wash it away. Fat-based soaps and emulsifiers (for example, baby shampoo, castile liquid soap, or soft soap) are much more effective than liquid or powder detergents. Detergents tend to dry the skin and

should not be used. Soap and water is best used during patient thorough decontamination, but can also be used for immediate (gross) and operational patient decontamination if available and practical. It is not practical to use soap and water on the JSLIST or similar protective garment as it will dampen the garment and reduce its protective abilities. It is also not advisable to use hot water for skin decontamination since it will open skin pores allowing chemical agents to easily penetrate and absorb into the skin. For better results, use tepid or lukewarm water with soap.

(c) Other locally available absorbent material. Any material that can absorb a liquid and then be brushed or scraped from the skin without abrading it, can be used as an effective skin or equipment decontaminant to remove liquid agents. Clean sawdust, clay dirt, baking powder, fuller's earth, baby wipes, can be put on the agent found on the skin or equipment, allowed to absorb it, and then carefully wiped away. Large quantities of thickened liquid agent can be removed from clothing and skin by initially scraping it off with an uncontaminated stick or similar device. Clean sand can be used on equipment but it is not advisable to be used on skin since it might be too abrasive and may cause the skin pores to open thus absorbing the chemical agent.

(d) The 0.5 percent hypochlorite (1/2 percent, dilute household hypochlorite) solution. This is the least preferred and only used as an alternative skin decontaminant where there is limited water and dry decontaminants are not available. It can be used for washing off chemical, biological, and radiological agents. This may offer some neutralization of the chemical and biological agents, but not for radiological agents. A 0.5 percent hypochlorite concentration poses little risk of causing skin damage if mixed correctly in 9 parts water to 1 part hypochlorite solution, however, it may cause skin irritation and opens skin pores. To work effectively, it should be wiped on the contaminated areas of the skin with gentle scrubbing of those areas so that contamination is not spread. It can then be left on the skin for several minutes and later rinsed with clean water (several seconds to minutes later). Its oxidation effects are limited and its protective ratio is not significantly different than soap and water. Using copious amounts of soap and water is preferred and will better loosen the agent and help lift it off of the skin with washing. The 0.5 percent hypochlorite solution is used for skin decontaminant as a last resort.

(e) Reactive skin decontamination lotion (RSDL). The RSDL is a liquid decontaminant dispensed on a sponge. The Food and Drug Administration (FDA) has cleared RSDL for use by the US military intended to remove or neutralize CW agents and T-2 fungal toxin from the skin. It is expected to replace the M291, SDK. It washes away chemical agent contamination and also neutralizes the effects of many agents. The RSDL can be used for the decontamination of intact skin around wounds, but is not approved for the decontamination of wounds. The RSDL is a Class VIII item with a basis of allocation of one packet per individual. For more information regarding RSDL, refer to FM 4-02.285/MCRP 4-11.1A/NTRP 4-02.22/AFTTP (I) 3-2.69.

## (2) Wounds.

(a) Clean or sterile water (such as an IV bag of saline) is the most appropriate material for the irrigation of the eyes and contaminated open wounds. Soft tissue closed wounds can be irrigated with clean water, IV saline, or soap and water. Deeper wounds, such as contaminated abdominal or thoracic cavity wounds or contaminated open intracranial (head) injuries should not be irrigated in the field.

(b) Wound irrigation does not necessarily completely decontaminate the wound, but can help dislodge foreign material (such as pieces of clothing or metal which could hold agent) for recovery by aspiration with a large bore sucker, forceps, or other no-touch technique.

(3) Equipment.

(a) The 5 percent hypochlorite (full strength household liquid hypochlorite) solution. This is effective for decontaminating equipment contaminated by CW agents or biological agents. It is not necessary to use this type of solution for radiological contamination as water or soap and water is best for this. The 5 percent hypochlorite solution works by rinsing away the agent while causing an oxidative, burning, chemical reaction with the agent which will neutralize chemical agent toxicity and kill biological agents. This solution should never be allowed to touch the skin as its alkalinity will redden, burn, and damage skin. Damaged skin will lose its protective qualities and will allow chemical agent to travel through it more rapidly and in greater amounts. To effectively neutralize a chemical agent, the 5 percent hypochlorite solution must be in contact with it for at least 10 minutes to 30 minutes. Equipment decontaminated with hypochlorite should be thoroughly rinsed with water or soap and water before use. It is important that hypochlorite not be used on sensitive electronic equipment as it will cause oxidation and rust the equipment. Because of its highly reactive, very strong base, high pH level, and oxidative characteristic, this solution may react with some TIC.

**CAUTION**

Five percent hypochlorite (full strength household liquid hypochlorite) solution is highly reactive and oxidative. It should NEVER be used on skin. It can damage sensitive electrical equipment. Equipment decontaminated with hypochlorite solution must be thoroughly rinsed with clean water before use.

(b) Soap and water. Generous amounts of soap and water work well to decontaminate equipment contaminated by chemical, biological, radiological, and nuclear contaminants. Soap and water dilute most chemical agents but do not neutralize them. It removes biological agents, but will not destroy anthrax spores. Runoff should be collected and killed with hypochlorite or sporicides. Soap and water will remove radiological particles, but runoff must be contained as it contains particles that remain radioactive.

---

Note: Soap and water does not destroy biological or radiological contamination. Water runoff should be collected.

---

(c) M295 Equipment Decontamination Kit (EDK). This can be used on equipment contaminated by liquid chemical agent. The EDK is not effective for dry agents such as biological spores, radioactive particles, or dry chemical agents. The EDK contain the same resin material that is in the M291 SDK only the M295 is stronger in concentration. See Table V-3 for more information.

(4) Marking buckets. During the decontamination of chemically contaminated patients, cutting tools should be placed in buckets of 5 percent hypochlorite solution. It is critical that these buckets be well marked (color coded and labeled) so that the 5 percent solution is not used on the skin. Darker colored buckets such as red or orange can be used for this solution. Lighter colored buckets can be used for soap and water or 0.5 percent hypochlorite solutions if used when soap is not available. Hypochlorite in solutions above 0.5 percent will cause skin alkaline burns that damage the skin and increase agent absorption.

**Table V-3. Summary of Appropriate Uses for Decontaminants**

<b><i>Decontaminant</i></b>	<b><i>Type of PDS</i></b>	<b><i>When and where used</i></b>
M291.	All types of PDS with limited water or freezing temperature conditions.	For dry decontamination of liquid chemical agents only; if water is not available or the ambient temperature is freezing; used on skin and equipment.
M295.	All types of PDS with limited water or freezing temperature conditions.	For dry decontamination of liquid chemical agents only, used on equipment.
Soap and water.	Used at all PDS and is most preferred.  Note: This is the primary decontaminant that is used for PDS with plumbed tentage and on water vessels.	Used for— <ul style="list-style-type: none"> <li>• Skin (copious amounts).</li> <li>• Equipment (copious amounts).</li> <li>• Best for washing away chemical, biological, and radiological agents. Does not neutralize or kill these.</li> <li>• Used to wash down TAP aprons of decontamination team members and rinse decontamination team member gloves washed with 5 percent hypochlorite (bleach) solution.</li> </ul>
0.5 percent hypochlorite (1/2 percent, dilute household bleach) solution.	PDS with minimal equipment.	On skin. This is the least preferred and used as the last resort. If used, not for full body wash.
5 percent hypochlorite (full strength household liquid bleach) solution.	PDS with minimal equipment: patient mask hood; decon team member gloves.  Decontamination equipment (10 to 30 minutes contact time then rinse).  All PDS: Soak cutting tools (chemical and biological agents only); for radiation use soap and water.	Used only on equipment, NOT on skin. Not used with radiological agents. Used for chemical and biological agents to— <ul style="list-style-type: none"> <li>• Wipe down rubber mask hoods.</li> <li>• Wash patient and decontamination team member gloves (then rinse with fresh water).</li> <li>• Fill/pail/bucket for cutting tools.</li> <li>• Decontaminate litters (then rinse with fresh water).</li> <li>• Wipe down equipment (wait for 10 to 30 minute contact time and then rinse).</li> </ul>
Locally available absorbent material— <ul style="list-style-type: none"> <li>• Clean sand.</li> <li>• Baking powder.</li> <li>• Fuller's earth.</li> <li>• Baby wipes.</li> <li>• Flour or bread.</li> <li>• Other dry, nontoxic, absorbent items.</li> </ul>	Any PDS.	For dry decontamination of liquid chemical agents only on skin and equipment; used if water and M291 (skin/equipment) or M295 (equipment only) are not available or ambient temperature is freezing.

**Table V-3. Summary of Appropriate Uses for Decontaminants (Continued)**

Reactive skin decontamination lotion (RSDL).	Any PDS.	Will replace M291. Used for skin and equipment for all types of agents to wipe the contaminant away. Can neutralize some chemical agents and biological toxins.
--	----------	---

## 7. Detection Devices Used During Patient Decontamination

a. Detectors can be used at the drop-off point, to assess which patients require decontamination or after the decontamination process to check for thoroughness of decontamination. Their use is dictated by unit operating plans and specific Service tactics, techniques, and procedures (TTPs) and CONOPS.

b. There are currently no hand-held detectors for biological agents that would be appropriate for patient decontamination operations.

c. There are a variety of RADIAC meters appropriate for patient decontamination operations. The RADIAC meters used for this purpose should measure alpha, beta, and gamma radiation and should have a pancake probe. Suggested military models include AN/PDR-77, AN/VDR-2, or ADM-300 RADIAC set. In the event of radiological contamination, these can be deployed at the same locations as the chemical monitors, such as the ICAM. They can be used to screen for radiologically contaminated casualties and equipment at the ECP and to verify the effectiveness of decontamination.

d. Currently fielded CW agent detection/monitoring equipment does not identify all possible CW agents or TICs. Military detection devices that are currently fielded include, but are not limited to—

(1) Chemical Detector Paper, M8. Detects liquid G nerve agents but does not differentiate between them. It identifies liquid V nerve agent. Detects liquid H blister agents but does not differentiate between them. It does not detect vapors. This could be used by decontamination personnel to help detect liquid agent residue on a patient before or after decontamination.

(2) Chemical Detector Tape, M9. Detects liquid H, G, and V agents but does not differentiate between them. It does not detect vapors but can detect aerosol sprays. This is typically worn on protective gear and can be checked by decontamination teams before the individual's protective ensemble is removed. It is normally not used as a detector during the decontamination process but examining the patient's M9 can help to determine if the individual was exposed to liquid and aerosol forms of a chemical agent.

(3) Chemical Agent Monitor/Improved Chemical Agent Monitor. This device monitors levels of nerve and blister agent vapors in the air (but only one agent at a time). It does not monitor liquid, except for the vapors that a liquid agent might give off. It is typically used after the presence of nerve or blister agent has been established to pinpoint contaminated areas on clothing and protective ensemble. The ICAM may be used at the ECP to assist in determining if decontamination is required and at the end of the decontamination process to verify the effectiveness of decontamination. It may also be used within airlocks on chemically protected MTFs to verify decontamination of individuals inside the airlock entry way. The ICAM can be deployed in pairs, with one on G (nerve agent) mode and one on H (vesicant) mode, or individually if the threat is known and medical signs and symptoms give an indication of the type of agent exposure (for example, the patients present with reddened skin or blisters then

the hazard is likely mustard (H), but if the patients are sweating profusely, have difficulty breathing, are vomiting, and have muscle twitches, then it is likely nerve agent). For instructions on the use and operation of the ICAM refer to Technical Manual (TM) 3-6665-331-10/TO 11H2-20-1. There are similar commercial off-the-shelf equivalents that can detect vapor hazards. These must first be approved for military field use.

---

Note: Chemical Agent Monitor Maintenance. The ICAMs employed in the decontamination station must be operated 6 to 8 hours every 2 weeks to maintain acceptable performance. This regular operation should be achieved using the alternating current power supply with D-Cell adapter or the lithium battery. Alkaline D-Cell batteries (4 per CAM/ICAM) and lithium batteries should be checked/replaced at regular intervals.

---

(4) Automatic Chemical Agent Alarm M8A1. This consists of the M43A1 detector and one or more M42 remote alarms (up to 5 alarms). This is not used to detect agent on a patient, but is used to monitor an area for possible air contamination in clean areas (the cold zone) and areas upwind of the decontamination area and MTF. It can be used as a monitor to establish a vapor control line (VCL) between the hot line and the MTF. It serves as an early warning alarm for G nerve agent and HD vesicant vapors only.

(5) The M22A Automatic Chemical Agent Detector Alarm. This is replacing the M8A1 and consists of the M88 chemical detector and one or more M42 remote alarms (up to 5 alarms).

## **8. Safety, Heat Injury Prevention, and Water Consumption**

a. Of greatest concern to decontamination team members is heat injury and musculoskeletal injury from performing moderate to heavy (patient triage and treatment) and heavy work (carrying litter patient and decontaminating patients) while wearing the protective ensemble. The frequency of accidents, in general, appears to be higher in hot environments than in more moderate environmental conditions. One reason is that working in a hot environment lowers the mental alertness and physical performance of an individual. Increased body temperature and physical discomfort promote irritability, anger, and other emotional stresses which sometime cause workers to overlook safety procedures or divert their attention from hazardous tasks. It is critical that these issues be addressed throughout PDS operations.

b. A safety officer must be appointed for PDS operations. This can be the PDS NCOIC or appointed individual selected by the commander. The primary duty of this individual is to conduct an initial and ongoing risk assessment prior to setting up the PDS and to personally monitor the status of decontamination team members working on the warm side of the hot line at all stations from the ECP to the hot line. This individual must not be involved in PDS tasks such as triage, treatment, litter carry, or patient decontamination. They must be free to move around the warm zone. In addition to personally checking with decontamination team members and observing them closely for signs of heat or musculoskeletal injury, this individual also manages work/rest cycles, monitors temperature and wet bulb heat category conditions, ensures adequate fluids are available for decontamination team members, and enforces safe patient lifting techniques.



c. Worker musculoskeletal injury can easily occur from long periods of patient lifting and litter carrying or injuries caused by falls while wearing protective ensemble. To reduce these injuries the following strategies can be implemented:

- Clear routes within the PDS to reduce tripping hazards.
- Establish multiple decontamination lanes far enough apart to reduce cluttered work areas.
- Ensure that garbage bags containing contaminated waste material are moved from the decontamination lanes to the dirty dump on a regular basis to reduce tripping hazards in the decontamination area.
- Ensure that litter teams move litter patients at a safe speed and do not run.
- Reduce distances that litters need to be transported by litter teams.
- Triage areas and litter transport lanes should be well marked for night operations.
- Enforce proper lifting and litter carry techniques throughout PDS operations.
- Ensure that personnel performing litter carries and patient lifting are fit for the demands of the task.
- Enforce frequent rest breaks.
- Use equipment (for example, roller systems, litter stands, or NATO litter carriers) when available.

## 9. Heat Injury

a. Excessive exposure to a hot work environment, which is the case when the protective ensemble is worn, can bring about a variety of heat-induced disorders/injuries. Chemical protective ensembles make it difficult for the body to cool itself as the ensemble prevents sweat from readily making contact with the air to help cool the skin. This inhibits heat transfer from the body. Refer to Technical Bulletin, Medical (TB MED) 507/Air Force Pamphlet (AFPAM) 48-152(I) for more information.

(1) Heat stroke. This is a life-threatening medical condition associated with working in hot environments. It occurs when the body's temperature regulatory system fails and sweating becomes inadequate. The body's only effective means of removing excess heat is compromised with little warning to the victim that a crisis stage has been reached.

### **DANGER**

**Unless the heat stroke victim receives quick and appropriate medical treatment death can occur.**

(2) Heat exhaustion. This includes several clinical disorders having symptoms which may resemble the early symptoms of heat stroke. Heat exhaustion is caused by the loss of large amounts of fluid by sweating, sometimes with excessive loss of salt.

(3) Heat cramps. Heat cramps are painful spasms of the muscles that occur among those who sweat profusely in the heat and who drink large quantities of water but do not adequately replace the body's salt loss.

b. Humans are, to a large extent, capable of adjusting to heat. This adjustment to heat, under normal circumstances, usually takes about 5 to 7 days, during which time the body will undergo a series of changes that will make continued exposure to heat more endurable. Measures that can be taken to reduce heat load on the individual include—

- Ensure that work/rest cycles are enforced and that manning is adequate to accomplish this.
- Provide shaded areas for rest on the warm side of the hot line.
- Provide shaded covering (for example, camouflage netting or open tentage) over decontamination and warm side triage and treatment areas.
- Reduce MOPP level when appropriate.
- Maintain adequate supplies of drinking potable water for decontamination team members.

c. It is critical that the workload for decontamination teams be distributed among the members so that workers do not keep working to the point of heat or musculoskeletal injury. In a high OPTEMPO, team members may disregard this important guidance. Not enforcing appropriate work/rest cycles will increase the risk for decontamination team member injury and will deplete the manpower pool. Work/rest cycles ensure adequate team member hydration giving the body an opportunity to get rid of excessive heat and break the effects of fatigue. Refer to Table V-4 for work/rest cycles and water consumption information.

**Table V-4. Work/Rest Cycles and Water Consumption (Without Protective Ensemble)**

<i>Heat Category</i>	<i>WBGT Index</i>	<i>Easy Work</i>		<i>Moderate Work</i>		<i>Hard Work</i>	
		WORK/ REST MIN	WATER INTAKE QT/HR	WORK/ REST MIN	WATER INTAKE QT/HR	WORK/ REST MIN	WATER INTAKE QT/HR
1 (WHITE)	78-81.9	NL	½	NL	¾	40/20	¾
2 (GREEN)	82-84.9	NL	½	50/10	¾	30/30	1
3 (YELLOW)	85-87.9	NL	¾	40/20	¾	30/30	1
4 (RED)	88-89.9	NL	¾	30/30	¾	20/40	1
5 (BLACK)	> 90	50/10	1	20/40	1	10/50	1

– The work/rest times and fluid replacement volumes will sustain performance and hydration for at least 4 hours of work in the specified heat category.

– Hourly fluid intake should not exceed 1 quart (qt) and daily fluid intake should not exceed 12 quarts.

– NL means no limit to work time per hour (hr).

– Rest means minimal physical activity while sitting or standing, accomplished in the shade if possible.

**CAUTION**

Wearing protective overgarments adds 10°F (5.6°C) to the wet bulb globe temperature (WBGT) index and wearing body armor increases this by another 5°F (2.8°C). The TAP apron adds an additional 10 degrees to the WBGT index.

d. A worker may produce as much as 2 to 3 gallons of sweat in the course of a day's work. Because many heat disorders/injuries involve excessive dehydration of the body, it is essential that water intake during the workday be about equal to the amount of sweat produced.

e. Most workers exposed to hot conditions drink less fluids than needed because of an insufficient thirst drive. A worker, therefore, should not depend on thirst to indicate when and how much to drink. Five to seven ounces of liquid should be consumed every 15 to 20 minutes to replenish the necessary fluids in the body. Water intake should not exceed 1 quart per hour or 12 quarts per day, as excessive water consumption (overhydration or hyponatremia) can dilute the salt content of the blood to the point where it interferes with brain, heart, and muscle function. This *water poisoning* can result in confusion, nausea, vomiting and/or seizures.

### CAUTION

Hourly fluid intake should not exceed 1 quart (one canteen), and daily fluid intake should not exceed 12 quarts (12 canteens).

f. Heat acclimated workers lose much less salt in their sweat than do workers who are not adjusted to the heat. The average Service member diet contains sufficient salt to acclimatized workers even when sweat production is high. If for some reason, salt replacement is required, the best way to compensate for the loss is to add a little extra salt to the food. Salt tablets should not be used unless directed by a physician.

g. Persons with heart problems or those on *low sodium* diets who work in hot environments should consult a physician about what to do under these conditions.

## 10. Core Components of the Patient Decontamination Site and Patient Flow

a. All military services and all roles of medical care use a similar patient flow during patient decontamination operations. Each Service may use different types of equipment and procedures. This paragraph provides an overview of core components that are found in all PDSs, whether they are set up using minimal resources, plumbed tentage with showers and roller systems, or on board ship.

b. When establishing a PDS, all component areas noted in this paragraph should be considered and addressed.

(1) Entry control point and drop-off point is an area downwind from the triage and decontamination areas. This is where patients arrive at the PDS. On land, this incorporates road access for evacuation vehicles as well as medical evacuation rotary-wing landing areas. These avenues must be organized so that smooth traffic flow occurs during patient drop-off. On a water vessel this area would consist of the flight deck or area where aircraft and water landing craft discharge patients to the ship.

(a) Entry control point when on land is located along an access road to the drop-off point. Security must be provided to control access to the PDS. Security personnel must meet vehicles upon arrival, quickly interview drivers/escorts, and get information from the drivers/escorts as to the number of patients, types of injuries, and types of contamination. They relay this information by radio to the drop-off point and PDS OIC/NCOIC. On watercraft, the ECP might be located at the transport air or watercraft loading area on land.

(b) The drop-off point is where patients are off loaded from vehicles and brought to the triage area. The drop-off point is staffed by augmentees who direct traffic flow, unload

vehicles and move patients to the triage area, remove patient weapons and equipment, and perform quick pat-down searches of patients.

(c) If adequate chemical and radiological monitoring devices and trained staff are available, a monitoring station can be set up at the drop-off point to determine who are contaminated and require decontamination. Personnel at the ECP and drop-off point assume MOPP Level 4 or equivalent OSHA Level C when contaminated casualties are expected.

(2) Warm side (dirty side) triage area. The triage area is located near the drop-off point in the PDS warm zone. Patients are moved to this area from the drop-off point.

(a) Casualties are simultaneously triaged as to their need for medical care, their priority for patient thorough decontamination, and their priority for evacuation to the next role of care. One patient may be medically triaged as Immediate, but not have priority for decontamination until they are medically stable. Another may have priority for medical evacuation, but be Expectant or Delayed. The purpose of triage is to effectively allocate the medical resources available.

(b) This area should initially be large enough to allow for an influx of many patients. The triage area is located adjacent to or can be collocated with the warm side (dirty side) EMT area.

(c) Within the triage area, casualties are moved to either the Immediate (warm side, dirty, EMT), Delayed, Minimal, or Expectant treatment areas. A patient is retriaged as his condition changes. The following is suggested as a placement for specific treatment areas to improve patient flow through the PDS:

- The Immediate category patients are moved to the warm (dirty side) EMT area. This area is located between patient triage (closer to triage area to minimize the time it takes to move from triage area to dirty EMT) and the entrance to the litter decontamination lanes. This way they can be moved to litter decontamination without interfering with the traffic flow from other patient categories.
- The Delayed patient area should be positioned near the entrance to both the litter and ambulatory decontamination lines. This way delayed patients can be processed through either the litter or ambulatory lanes when the lanes become available.
- The Minimal category patients should be positioned near the ambulatory patient area so that if medical care on the clean side of the hot line is needed they can process through the ambulatory lane when it becomes available and will not interfere with the flow to the litter lanes.
- The Expectant category patients should be located near the EMT area, but farther away from the decontamination lanes, so that they can be retriaged and stabilized for decontamination if the EMT area no longer has patients in it. The expectant patient should not be abandoned, but should be separated from the view of other casualties.

(d) Casualties are retriaged as they progress through the EMT and decontamination process.

(e) Personnel in the triage area wear MOPP Level 4 or equivalent OSHA Level C. One triage officer, but preferably two or more (if available), is assigned to this area. The triage officer should be trained in triage. These are typically experienced medical personnel (senior health care specialist, senior corpsman), nurses, or physician's assistants. A discussion of medical triage and treatment protocols for CBRN casualties can be found in FM 4-02.285/

MCRP 4-11.1A/NTRP 4-02.22/AFTTP (I) 3-2.69; FM 8-284/NTRP 4-02.23/AFMAN (I) 44-156/MCRP 4-11.1C; and FM 4-02.283/NTRP 4-02.21/AFMAN 44-161(I)/MCRP 4-11.1B.

(3) Warm side (dirty side) emergency treatment area.

(a) Patients triaged as Immediate for medical treatment are sent to the warm side dirty EMT until their condition is stabilized for patient thorough decontamination or stabilized for dirty evacuation to another MTF. It is suggested that this area be located between the patient triage and the entrance to the litter decontamination lanes.

(b) An initial quantity of medical supplies is located in this area and procedures for resupply must be established. It is important to only put enough supplies here for the anticipated number of patients so that unused supplies are not in danger of becoming contaminated.

(c) The warm side EMT area should be large enough to expand and handle an influx of patients.

(d) Personnel in the warm side EMT area assume MOPP Level 4 or equivalent OSHA Level C. Two or more trained medical personnel are assigned to this area to retriage patients and provide lifesaving medical care while wearing protective ensemble. Staffing should consist of trained and experienced medical personnel (health care specialist, corpsman), nurses, or physician's assistants.

(4) Warm side disposition (dirty evacuation). This is an area located in the vicinity of the warm side EMT area.

(a) Patients who require rapid evacuation to another MTF and who have undergone operational decontamination are medically stabilized, and staged for pick up and transport by designated *dirty* evacuation assets (ground, water, or rotary-wing aircraft) are located here.

(b) Gross contamination is removed from their protective ensemble before being loaded onto the designated *dirty* evacuation vehicle.

(5) Contaminated waste dump area. This area is located away from the decontamination area and clean areas. On land it is at least 75 meters downwind from the drop-off point. On ship, it is at the aft of a ship and away from air intake areas. Bags of contaminated clothing and bandages are taken to this area.

(a) On land, contaminated waste are buried and marked with the appropriate hazard markers. The locations are marked on maps and communicated to headquarters so that the waste can be picked up and properly disposed of. These locations should be guarded to prevent looting of hazardous waste materials by locals who are not aware of the hazards. This may not be possible on the fluid battlefield.

(b) On a water vessel these items are contained until they can be disposed of by proper removal or disposed of in the ships incinerators.

(6) Temporary morgue. This is a location for patients who died of wounds (DOW) after arrival at the MTF or while going through the decontamination process at the PDS. Supported units do not bring their dead to this area. This is only for the temporary storage of the remains of those who DOW. This should be in a cool shaded area away from the triage area. The following steps should be taken:

- Service member's assigned unit should be notified as soon as the contaminated HR are placed in the temporarily established morgue.
- Tag the contaminated HR with DD Form 1380.

- Secure the contaminated HR by placing them in a contaminated human remains pouch (CHRP). If the CHRP is not available at the PDS, contact the battalion S-4/the HSL section to acquire the CHRP.
- The contaminated HR will remain on the warm side of the hot line (temporary morgue) and handled according to theater policy until they are retrieved by the Service members' unit or mortuary affairs to be transported to the MADCP.

(7) Litter patient decontamination line. This is an area located between the warm side EMT and the hot line.

(a) Patients must be medically stable enough to undergo decontamination before they are brought to the litter patient decontamination area.

(b) Litter patient decontamination lanes are established in this area. Ideally, more than one litter patient decontamination lane should be established depending on the number of patients expected.

(c) Personnel assigned to this area assume MOPP Level 4 or equivalent OSHA Level C. Those performing decontamination also wear a TAP apron over their protective ensemble to keep their protective ensemble dry and to allow them to decontaminate their aprons before conducting patient transfers. With the exception of the Air Force, and some Navy units who have trained medical teams throughout the decontamination process, this area is manned by augmentees who are closely supervised by medical personnel.

(8) Ambulatory patient decontamination line. This area is usually located parallel to the litter patient decontamination line.

(a) Ambulatory patients who need to see the physicians at the MTF are processed through this area.

(b) Patients who can be treated in the warm side EMT area and then sent back to their unit should not go through ambulatory patient decontamination.

(c) Ambulatory individuals who do not have medical complaints should be processed through troop decontamination lanes and not through the medical ambulatory decontamination lane.

(d) Medical and decontamination team members can be processed to the clean side through this area or processed through troop decontamination, if it is collocated.

(e) Personnel assigned to this area assume MOPP Level 4 or equivalent OSHA Level C. Those performing decontamination also wear a TAP apron to keep their protective ensemble dry. This area is usually manned by augmentees and at least one medical personnel if available to supervise ambulatory patients as they process through the line and assist one another.

(9) Clean and wastewater storage bladders. These are only used for a PDS with plumbed tentage and shower systems. The bladders are located in the proximity of the decontamination tent. The PDS must be located in areas where the bladders can easily be accessed by vehicles to fill the clean bladder and pump out or pick up and transport the wastewater bladder. The clean and wastewater bladders must not be located next to each other, but ideally should be on opposite sides of the tent. The wastewater bladder must be located farther away from the tent if possible.

(10) Contamination check area. This area is located between the decontamination lines and the hot line.

(a) Here thoroughness of decontamination is checked for chemically and radiologically contaminated patients using the appropriate monitoring devices (for example, chemical: ICAM or M8 paper, radiological: AN/PDR- 77 or AN/VDR-2). Self-sealing plastic bags containing the patient's personal items can also be unzipped and the monitors used to check for contamination of the items inside them. If the items are contaminated they can be decontaminated and placed in a new bag once they are determined to be free of contamination or contaminated items can be bagged and sent to a secure holding area for later disposition.

(b) The station can be set up between the litter patient and ambulatory patient decontamination lines if detectors and those trained to use them are in limited supply.

(c) For shipboard decontamination, this often takes place in the second compartment of the water vessel before the patient and decontamination team members are allowed inside the ship.

(d) The decontamination check area may not be used in some instances such as with the Air Force's small shelter patient decontamination system. This system supplies ample amounts of soap and water for thorough patient decontamination rendering the need for a contamination check unnecessary due to the completeness of the process.

(e) Locating this station inside a plumbed decontamination tent may pose challenges as the spray inside these tents will often create some aerosolization of agent causing the ICAM alarm to activate.

(11) Litter decontamination station. For the decontamination operation with minimal resources, this is located on the dirty side of the hot line. It is located where warm side litters are washed and readied for use by new patients. Buckets and sponges with 5 percent hypochlorite solution are available, as well as water to rinse the litters. With a shower/roller system litter decontamination may only entail sending the litter back through the decontamination station for a wash.

(12) Weapons and contaminated personal effects storage area. This is a guarded area where weapons and patient personal effects are secured and inventoried. This is located on the warm side of the hot line. Items from this area are moved through the contamination check area and decontaminated as needed before being moved across the hot line. If personnel are limited, this area may need to be well organized and under the observation of personnel serving as security augmentees.

(13) Warm (dirty) side rest area. This area is located on the warm side of the hot line. This should be a shaded area (for example, trees, a building, or tentage). The PDS team members can rest and drink water in this area while remaining in their protective ensemble. The warm side water point is located here. Water that will be used for decontamination can be stored here so that it is out of the way of the areas of greatest contamination (drop-off point, dump, and decontamination lines) but still accessible to decontamination team members.

(14) Hot line and shuffle pit. This is the line that separates the PDS warm zone (dirty side) from the cold zone (clean side) where the MTF is located. No liquid or solid contamination crosses the hot line. The line must be indicated in some way (such as by a barrier, tape line, or airlock) so that all personnel know not to cross the line unless they are properly decontaminated. It is best to indicate this area with a specific barrier such as concertina wire to protect the MTF. See Figure V-1.

(a) A shuffle pit or boot rinse is located at the hot line to ensure that footwear worn by individuals working in the shuffle pit area is decontaminated. A shuffle with a sand hypochlorite mixture is only used for a PDS with minimal equipment and is only useful when chemical or biological contamination is evident. A boot rinse can be used on a water vessel or with a plumbed decontamination tent with sprayers. The hot line may also be referred to as the liquid control line (LCL).

(b) At the hot line, information on the patient's FMC is transferred to a clean card and litter patients are transferred to a clean litter to ensure that contaminated FMCs or litters do not cross the hot line. Litters used on warm side of the hot line will stay on the warm side and those used on the cold side of the hot line stay on the cold side.

(c) Team members on the warm side of the hot line are the decontamination team members who have decontaminated the patient. They will bring the patient to the hot line from the warm side. They are still wearing their protective ensemble with TAP aprons. The patient is received on the clean side of the hot line by a team of at least one medical personnel and two augmentees. They take the patient from the decontamination team while trying to avoid physical contact with the warm side decontamination team members. Those assigned to the clean side of the hot line should be at MOPP Level 4 or OSHA Level C but do not require TAP aprons.

(15) Vapor control line. This is a line that encompasses the warm zone and is also located between the hot line and the clean side triage area and MTF. It is typically just upwind of the hot line by 10 meters. Patients and PDS team members remain masked until they cross this line. This line can be established using chemical vapor detectors such as the ACADA. A VCL is not needed for a radiological and biological agent hazard as there are no hazardous vapors from these agents.

(16) Triage/emergency medical treatment area (cold zone). This is an area beyond the hot line and VCL, where patients are retriaged and treated before entry or movement to the MTF. All patients entering this area are free of contamination. With large numbers of patients, this can be a holding and staging area for admission to an MTF or for clean evacuation to another MTF or for ambulance transport from a collocated decontamination area for a nearby MTF. Personnel assigned to this area do not need to wear protective equipment. The staff should protect themselves from infectious patients by practicing standard precautions and wearing appropriate respiratory protection to protect against infectious particles from coughing or sneezing patients.

(17) Disposition (cold zone/clean evacuation). This is an area adjacent to the cold zone triage/EMT area. Patients who have been decontaminated and stabilized can be staged for transport to another treatment facility. Personnel assigned to this area do not need to wear protective equipment unless standard precautions are required to protect them from infectious biological hazards however, periodic monitoring for hazards still need to occur.

(18) Clean side supply point. This is located on the clean side of the hot line, outside of the VCL. The PDS supplies are kept here and are handed across the hot line to the warm side when needed. This way all of the PDS supplies are not exposed to possible contamination. This area should be covered from the elements and protected in the event of chemical, biological, radiological, or nuclear attack or a wind shift from the battle area. Clean side water storage can also be located here for easy movement in water cans across the hot line.



## **11. Collocating a Land-Based Patient Decontamination Operation with Troop Decontamination Operations**

a. If personnel and material resources allow, it is ideal to collocate the PDS with troop decontamination so that manpower assets can be shared. Patient and troop decontamination lanes can be near to or parallel to one another, but must not be in the same lanes. Troop decontamination must not interfere with patient decontamination operations as timeliness of patient movement through decontamination once the patient is stabilized, is critical.

b. If a CW agent is used, the contaminated unit and the medical unit are collocated for decontamination, it is critical that there is ample room to establish a dirty side triage area just forward of the patient decontamination lanes as ongoing medical stabilization of patients throughout the decontamination process.

c. There must be adequate medical staff to man both the PDS areas (for example, conduct triage, supervise patient decontamination and provide EMT during decontamination) and also the supported MTF. An MTF will typically lack the medical personnel to staff both a collocated troop patient decontamination facility and another separate decontamination line immediately adjacent to the MTF. For more information on roles and responsibilities during DTD and patient decontamination, refer to Chapter III.

d. This collocated decontamination area must be close enough to the supported MTF so that the decontaminated patients can be easily transported to the MTF by designated clean ambulances or other vehicles.

## **12. Litter Patient Mask, Protective Ensemble, and Clothing Removal Procedures**

a. Procedures for Protective Ensemble and Clothing Removal. The steps to remove litter patient's protective ensemble are outlined here. The same procedures are used whether decontamination takes place using minimal equipment, a plumbed tent and roller system, or on a watercraft. Services differ slightly on how to cut overgarments (all are noted here), however, the focus is to contain any contamination in and on the protective ensemble so that it does not spread and contaminate the patient.

### **b. Mask Decontamination.**

(1) Wipe/sponge down the voicemitter, eyelets and outserts of the mask with the M295 or 5 percent hypochlorite solution. While wiping down the filter, cover the inlet of the C2A1 filter canister with a hand or gauze momentarily to keep liquid out of the inside of the canister where it could wet the charcoal, reduce filter efficiency, and clog the filter. Rinse the sponge well or replace the sponge if needed.

(2) If the mask has an attached rubber hood, then wipe down the hood using the M295 or 5 percent hypochlorite solution. Do this by starting at the top of the head and wiping down towards the litter and shoulders. Rinse the sponge well or replace the sponge if needed.

c. Remove The Hood. Hoods are of two general types: those that are part of the overgarment and those that attach to the mask.

(1) For integral hoods that are part of the overgarment (such as the JSLIST, USN garment, or Saratoga), the hood is removed by cutting it starting from the top center and cutting toward the rear of the hood. In the case of the litter patient, the material of the cut hood will lie flat on the litter. No decontamination of this hood is necessary. See Figure V-2 below.



**Figure V-2. Cutline for Hoods Integral to Overgarments**

(2) For hoods attached to the mask, first unfasten or cut the shoulder straps. Then begin cutting at the bottom front of the hood and cut up to the bottom of the mask. Then cut any hood straps that connect the hood to the mask. Finally, cut from the center of the forehead, over the top of the head (towards the litter) to the back of the head, so that the hood will lay flat on the litter under the patient's head. See Figure V-3 below.



**Figure V-3. Cutline for Hoods Attached to Mask**

d. Decontaminate Head. After the hood is laying flat on the litter under the patient's head, decontaminate any exposed areas of the patient's head, hair, back of the ears, and neck that were not protected by the hood. The mask remains on the patient. This exposed skin is decontaminated using either the M291, soap and water, or 0.5 percent (1/2 percent) hypochlorite solution (least preferred). Do not use 5 percent hypochlorite solution on skin.

e. Remove the Field Medical Card.

(1) The medical personnel at the litter patient decontamination area should view the FMC prior to removal.

(2) Cut the patient's FMC tie wire, allowing the FMC to fall into a self-sealing plastic bag. Seal the plastic bag and decontaminate the outside of the bag with the M291, M295, or rinse the outside of the bag with a 0.5 percent hypochlorite solution or soap and water for radioactive contaminants. Place the plastic bag with the FMC under the back of the protective mask head harness straps. The FMC will remain with the patient until at the hot line where it will be transcribed on to a clean FMC.

f. Remove Patient's Personal Effects from Overgarment. Remove all items from the protective overgarment pockets and place them in a self-sealing plastic bag. Label the bag with the patient's identification and seal the bag. If the articles are not contaminated, place them in a separate bag from suspected contaminated items. Wipe down the outside of the bag with the M295 or dip it in a bucket of 5 percent hypochlorite solution. Dip in soap and water if the contamination is radiological. The bags are sent on the litter with the patient and checked for contamination at the contamination check area.

---

Note: The patient's identification tags stay around the patient's neck throughout the decontamination process. They are decontaminated with M291, soap and water, or 0.5 percent hypochlorite solution.

---

g. Cut the Patient's Overgarment.

(1) The overgarment jacket and trousers may be cut simultaneously. Two persons may be cutting clothing at the same time.

(2) Cutting is performed using sharp bandage scissors or long-handled seat belt cutters (for example, V-blade knife). Three or more cutting tools are needed for each team member who is cutting off patient clothing, as the tools typically become dull after cutting off the garments of 5 patients.

(3) Cut around bandages, tourniquets, and splints, leaving them in place. Only medical personnel remove bandages, tourniquets, and splints.

---

Note: Put the cutting device in a bucket of 5 percent hypochlorite solution after each complete line of cut and get another cutting tool, which has been sitting in the hypochlorite solution bucket, for the next cut. EXAMPLE: Cutting the sleeve from the cuff to the jacket collar is one cut. If a bucket of 5 percent hypochlorite solution is not available then the cutting tools must be scrubbed using the M295 or M291 between each cut or rinsed thoroughly in running soapy water.

---

**CAUTION**

Bandages may have been applied to control severe bleeding and are treated like tourniquets. Only medical personnel remove bandages, tourniquets, and splints.

h. Remove Overgarment Jacket.

(1) Unfasten or cut the hook and pile closures at the wrists.

(2) Make a cut, one up each sleeve from the wrist to the shoulder and then to the collar. Keep the cuts close to the insides of the arms so that most of the sleeve material is folded outward. An alternative is to start at the collar and cut down the sleeve to the wrist. See Figure V-4.

---

Note: It is essential that cutting tools be replaced as soon as they become dull. Dull tools make cutting difficult and can aerosolize dried agent particles as material is tugged by the cutting tool. A new cutting tool blade will be needed about every 5 patients.

---

(3) Cut the jacket drawstring at the bottom of the jacket and unfasten the hook and pile closures, moving from the waist to the neck and then unzip the jacket. If the jacket will not unzip then make a cut parallel to the zipper.

(4) Carefully fold the sleeves of the overgarment away from the patient's arms, exposing only the black liner. Avoid aerosolizing any dust particles on the garment or allowing the outside of the garment to touch the patient.

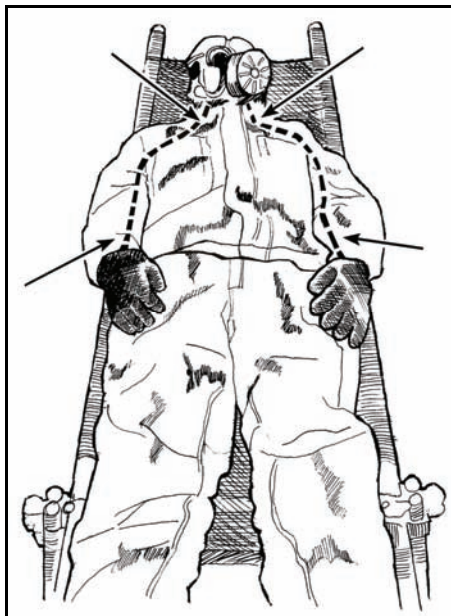

**Figure V-4. Cutline for Overgarment Jacket**

---

Note: To reduce aerosolization of dry agent on the protective overgarment, the overgarment can be lightly misted with water from a manually operated, compressed air sprayer before the patient's mask hood is removed or cutting begins. This will dampen the dry agent which can reduce its aerosolization. The spray from the mister must be very light so that it does not blow the dry agent into the air.

---

(5) Instruct the patient to keep his hands to the sides, away from the pieces of overgarment that are lying on his chest. If the patient is unable to lift his arms then one decontamination team member will hold the patient's gloved hand and perform this action. Another team member then carefully folds the chest sections over the outside of the litter. The patient's arms are then lowered to the sides, keeping the arms away from the area where the overgarment has been removed.

i. Remove Overgarment Trousers.

(1) Cut the trouser suspenders.

(2) Cut the leg closure cord and hook and pile fasteners at the ankle cuff.

(3) Using the cutting tool, cut from the ankle along the inseam of the left trouser leg until the crotch area is reached, and then cut across the zipper. An alternative is to start at the waist and cut from the waist, along the inseam of the trousers, to the ankle cuff.

(4) Allow the trouser halves to drape over the sides of the litter. Carefully roll and tuck the remaining cloth (at the crotch and on the inside of the legs) in on itself ensuring that only the black liner of the cloth is showing. Contain any dust or liquid that may be on the outside of the garment as you roll it. See Figure V-5 below.

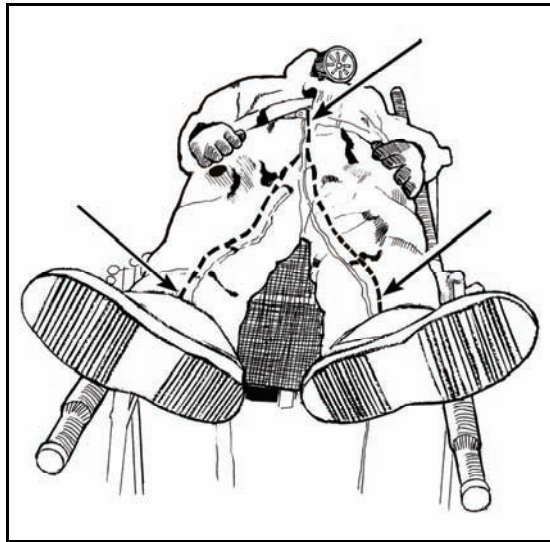

**Figure V-5. Cutline for Overgarment Trousers**

j. Remove Outer Gloves. This procedure can be done with one person on each side of the patient working simultaneously. Do not remove the patient's inner gloves (glove inserts) during this step.

(1) The decontamination team members will decontaminate their gloves with the M295 or dipping them in a 5 percent hypochlorite solution or soap and water for radiological contamination.

(2) Next, decontaminate the patient's gloves with the M295, a 5 percent hypochlorite solution or soap and water for radiological contamination.

(3) Instruct the patient to hold his arms away from the litter and upper body or, if he is not able to do this then hold the patient's gloves at the fingers.

---

Note: Always remove the patient's gloves over the sides of the litter.

---

(4) Grasp the cuff of the rubber glove, turning the glove inside out, and remove it. See Figure V-6 below.



**Figure V-6. Outer Gloves Removal**

(5) Carefully lower the patient's arms across his chest as each glove is removed. Avoid touching the patient's cloth glove liner or arm with your rubber glove.

**CAUTION**

Do not allow the patient's arms to contact the exterior (camouflage) side of the overgarment.

(6) Dispose of the contaminated rubber gloves by placing them in the designated contaminated trash bag.

(7) Decontamination team members then decontaminate their own gloves with the M295, or dipping them in a 5 percent hypochlorite solution, or use soap and water for radiological contamination.

k. Remove Overboots.

(1) Unfasten the boot closures.

(2) If the overboot will not come off, cut the boot from top to bottom along the centerline of the boot or along the inside of the boot. Fold the overboot down and gently pull on the heel until the boot is removed.

(3) If the older laced overboot is worn, then cut the overboot laces and fold the lacing eyelets flat outwards, and then remove the boot as noted above.

(4) Remove the two overboots simultaneously. This reduces the likelihood of contaminating one of the combat boots. While holding the heels off the litter, have a decontamination team member wipe the end of the litter with the M295 or 5 percent hypochlorite solution to neutralize any liquid chemical contamination that was transferred to the litter from the overboots. Soap and water can be used for radiological contamination.

(5) Lower the patient's heels onto the decontaminated litter.

(6) Place the overboots in the contaminated trash.

(7) Decontamination personnel dip their gloves in the 5 percent hypochlorite (full strength household liquid bleach) solution.

l. Remove the Patient's Personal Effects from his battle dress overgarment (BDO) or other work uniform (that is, battle dress uniform [BDU]/Army combat uniform [ACU]) pockets. Place personal effects in a self-sealing plastic bag. This can be the same bag used for items taken from the overgarment pockets if they were not contaminated, otherwise place these items in a separate bag. Seal the bag. A card with the patient's name and identification number must be placed inside the bag. Decontaminate the outside of the bag. Keep the bag with the patient or send it to a contaminated-item holding area where the items in it can be decontaminated or properly inventoried and disposed of.

m. Remove Combat Boots. Cut the bootlaces along the tongue. Remove the boots by pulling them towards you. Place the boots in the designated contaminated waste bag. Do not touch the patient's skin with contaminated gloves when removing his boots.

n. Remove Inner Clothing.

(1) Decontamination team members decontaminate their gloves and cutting tools.

(2) Cut or unbuckle the uniform belt.

(3) Cut the uniform jacket and trousers (such as work uniform) worn under the protective overgarment in the same manner as described above for the protective overgarment. Roll the jacket and trousers as described for the protective overgarment.

---

Note: For litter patient decontamination in a PDS, removal of inner clothing immediately follows removal of overgarment and both take place before the first patient lift. For shipboard decontamination the inner clothing is not removed until the patient enters the ship's first compartment. Once in the first compartment the same clothing cut off procedures noted above are used.

---

o. Remove Undergarments.

(1) Remove the patient's T-shirt. Dip the cutting device in the 5 percent hypochlorite solution between each cut. Cut both sleeves from the inside, starting at the elbow, up to the armpit. Continue cutting across the shoulder to the collar. Cut around bandages or splints, leaving them in place. Next, peel the T-shirt away from the body to avoid spreading contamination.

(2) If the patient is wearing a brassiere, cut it between the cups. Cut both shoulder straps where they attach to the cups and lay them back off of the shoulders.

**CAUTION**

The cutting tools must be decontaminated frequently (after each cut) to keep any contamination from contacting the patient's bare skin.

(3) Remove the patient's undershorts/panties by cutting from the lower side of the hip to the waist on both sides. Fold the front flap of the shorts/panties down between the patient's legs onto the litter. Do not allow the outside of the garment to touch the patient's skin.

(4) Remove the socks and cotton glove liners.

(5) Remove the patient's inner cotton gloves. Keep the patient's arms crossed over the chest if possible.

(6) Do not remove the patient's identification tags. These stay with the patient at all times. If not yet decontaminated then decontaminate the tags with the M291 or soap and water.

### **13. Ambulatory Patient Mask, Protective Ensemble, and Clothing Removal Procedures**

a. General. The step-by-step procedure outlined below describes the process for removing the clothing of the ambulatory patient. By using this method the correct and essential steps are not omitted. The focus is to carefully remove the overgarment so that cross-contamination from the protective ensemble to the patient's skin does not occur.

- This same clothing cut off procedure is used in all types of ambulatory patient decontamination settings.
- Monitoring for contamination may differ depending on the agent and the decontamination assets/equipment available.
- Bandages, splints, and tourniquets are only removed by medical personnel (medic/corpsman, physician, nurse, and physician assistant). A buddy or augmentee will cut around bandaged areas.
- One or more litter stands or chairs will be needed in the ambulatory decontamination area to help the patients steady themselves while having their clothing cut off (Note: These are not used on deck during shipboard patient decontamination as they can cause a safety hazard).

b. Decontaminate the Mask and Hood.

(1) Wipe/sponge down the voicemitter, eyelets and outserts with the M295 or 5 percent hypochlorite solution.

(2) While wiping around the filter, cover the inlet of the C2A1 canister with a hand or gauze momentarily to keep liquid out of the inside of the canister where it could wet the charcoal, reduce filter efficiency, and clog the filter.

(3) Hoods are of two types: those that are part of the overgarment and those that are attached to the mask.

(4) For integral hoods that are part of the overgarment, such as the JSLIST, no decontamination of this hood is necessary.

(5) For quick-doff hoods attached to the mask, first wipe down the hood using 5 percent hypochlorite solution, wiping the mask, and then the hood (starting at the top of the head wiping down towards the shoulders).

c. Remove Hood.

(1) Remove the quick-doff hood of the M40 mask.

(a) Dip the cutting device in a bucket of 5 percent hypochlorite solution or decontaminate/scrub the cutting tool with the M295.

(b) Cut the hood shoulder straps.

(c) Cut the neck cord, hood straps, and drawstring.

(d) Cut the quick-doff hood from the front bottom center up to the chin through the elastic band under the chin.



(e) Carefully roll back the hood away from the shoulders, keeping the outside of the hood away from the patient's skin and hair.

(f) Cut the hood straps that connect the hood to the mask.

(g) Place the hood in the designated contaminated trash bag.

(2) Remove the Hood of the JSLIST.

(a) Dip the cutting device in a bucket of 5 percent hypochlorite solution or decontaminate/scrub the cutting tool with the M295.

(b) Cut the hood starting at the front center and continue cutting across the top of the head toward the back.

(c) Fold the left and right sides of the hood away from the head and place on the shoulders. With an ambulatory patient the hood will lie on the shoulders of the individual.

---

Note: To cut the hood and the overgarment use sharp bandage scissors or a long handled seat belt cutter. Replace the cutter blades and scissors when they no longer make a smooth cut. Typically after cutting 5 complete uniforms/protective clothing, blades or scissors will need to be replaced. This is evident when the blades snag on the clothing and do not cut smoothly. After every complete segmental cut, decontaminate the scissors and long handled seat belt cutter along with the gloved hands of the Service member doing the cutting. This is done by dipping gloved hands and cutting tools in a bucket of 5 percent hypochlorite solution. If water is limited, scrub the tools with the M295. Use soap and water for radioactive contamination.

---

d. Decontaminate Head.

(1) Use soap and water, M291, or 0.5 percent hypochlorite solution (least preferred). Soap and water is appropriate for radioactive contamination.

(2) Cover inlet port of filter canister to prevent wetting or congesting it. The patient continues to wear their mask until they cross the VCL.

(3) Wipe any exposed areas of the patient's face that were not protected by the hood. This include the—

- Chin.
- Neck.
- Back of ears.

---

Note: After completing the hood removal, instruct the patient to move to the next station for the following steps. This station should be 10 to 20 meters upwind from the hood removal station for field decontamination with minimal resources. For plumbed tent systems all mask hood and clothing removal takes place in the clothing cut-off area. On ship, this takes place on the deck before movement into the first compartment.

---

e. Remove the Field Medical Card.

(1) The medical personnel at the litter patient decontamination area should view the FMC prior to removal.

(2) Cut FMC tie wire.

- (3) Allow the FMC to fall into a self-sealing plastic bag.
  - (4) Seal the plastic bag and decontaminate the outside of the bag.
  - (5) Place the plastic bag under the back of the patient's mask head harness straps.
- f. Remove Personal Articles from Pockets of the Overgarment.
- (1) Have the patient remove all items from the overgarment jacket and trousers and place them in a self-sealing plastic bag.
  - (2) Mark the bag with a name and identifying number and then moved with the patient to the next step in the ambulatory decontamination line.
  - (3) The patient must decontaminate their gloves before and after handling the bag.
- g. Removal of Patient's Overgarment Jacket.
- (1) The patient is standing and can hold on to a support such as a chair or litter stand (except for on the deck of a ship where these extra items are not permitted).
  - (2) The individual with a cutting tool stands in front of the patient and cuts the patient's protective ensemble.
  - (3) First, cut around all bandages and tourniquets. The augmentee will supervise the patients to cut one another's overgarments.
  - (4) Cut the hook and pile wrist closures.
  - (5) Cut the BDO jacket drawstring or the JSLIST draw-cord at the jacket bottom. On the BDO, unsnap the 3 snaps that connect the back of the BDO jacket and pants.
  - (6) Cut the overgarment jacket starting at the waist and cut toward the collar in a line parallel to the zipper or unfasten the hook and pile and unzip the zipper. If cutting the front is not possible, cut from the collar down the back of the BDO; or with the JSLIST continue the cut from the hood down the back and center of the jacket. This is best done using a long handled seat belt cutter.
  - (7) To help pull off the jacket, the augmentee moves behind the patient if the jacket is unzipped or cut at the front. If the jacket is cut down the back then the augmentee moves to the front of the patient.
  - (8) If the jacket was unzipped or cut at the front, instruct the patient to clench his fists and stand with his arms held down and extended backward at about a 30-degree angle. If the jacket was cut along the rear have the patient extend his arms forward at about a 30-degree angle.
  - (9) The patient positions his feet shoulder width apart.
  - (10) Grasp the jacket collar at the sides of the neck.
  - (11) Peel his jacket off the shoulders in a down and away motion, smoothly pulling the jacket inside out over the patient's fists.
  - (12) Place the overgarment jacket on the ground with the black side up.

---

Note: The patient's identification tags stay around the patient's neck throughout the decontamination process. They are decontaminated with soap and water, M291, M295, or 0.5 percent (1/2 percent) hypochlorite solution.

---

h. Remove the Trousers by Cutting.

(1) One augmentee should stand behind the patient and, if available, another at the front of the patient. The patient should have an object to help steady himself such as a chair or litter stand.

---

Note: Do not cut the trouser suspenders until the end of the process so that the trousers do not fall during cutting and get in the way of the cutter.

---

(2) The easiest way to cut the pants is from the front:

- Keep the pants zipped.
- Unfasten hook and pile ankle fasteners and begin cutting at the ankle. Cut along the inseam moving up toward the waist of the trousers.
- After cutting both trouser legs from ankle to waist, cut each suspender and allow the trousers to fall to the ground.
- Take the trousers and lay them on the ground, black side up, next to the patient.
- Later the patient will step onto this as he removes his overboots.

(3) An alternate method is to cut the trousers from the rear.

- In this case, first unfasten the hook and pile waist tabs.
- Start the cut at the ankle and move to the waist.
- Once the cuts on both legs are complete from ankle to waist, cut the suspenders below the suspender cross points and then above the cross points allowing the trousers to fall to the ground.
- Lay the trousers on the ground, black side up, next to the patient.

i. Remove the Overboots.

(1) Unfasten all boot closures.

(2) Step on the heel of the boot and have the patient step out of the overboot and step onto the black side of the cut trousers and overgarment top that are lying on the ground.

(3) Repeat this process for both boots. These overboots can be decontaminated and issued to other individuals.

(4) If the overboot will not come off, cut the boot from top to bottom along the centerline of the boot until the boot comes off.

j. Remove Outer Gloves.

(1) Decontamination team member decontaminate their gloves with the M295, M291, or 5 percent hypochlorite solution.

(2) The patient's gloves are decontaminated with the M291, M291, or 5 percent hypochlorite solution.

(3) Instruct the patient to hold his arms up, if possible, and away from his upper body. If the patient can not do this, then hold his gloves at the fingers.

(4) Grasp the cuff of the glove.

(5) Pull the cuff over the fingers, turning the glove inside out.

(6) Dispose of the contaminated gloves by placing them in the designated trash bag.

(7) Decontamination team members then decontaminate their own gloves again with the M295, M291, or 5 percent hypochlorite solution.

k. Remove Inner Gloves (Glove Liners). The patient should remove the liners to reduce the possibility of spreading contamination. The decontamination team member instructs the patient to remove the white glove inner liner using the following guidance:

- (1) Grasp the heel of glove liner without touching exposed skin.
- (2) Peel liner downward and off.
- (3) Drop it into the designated trash bag.
- (4) Remove the remaining liner in the same manner.
- (5) Drop it into the designated trash bag.
- (6) The patient then moves to the monitoring station.

l. Remove Personal Effects from BDU/ACU.

(1) Have the patient remove all items from his BDU/ACU and deposit them into a self-sealing plastic bag.

(2) Check for contamination. If not contaminated, the personal items remain with the patient. If contaminated they are moved to a contaminated item holding area.

m. Remove Inner Clothing/BDU/ACU.

- (1) Cut or unbuckle belt.
- (2) Cut the BDU/ACU pants following the same procedures as for the overgarment trousers.
- (3) Cut the BDU/ACU jacket following the same procedures as for the overgarment jacket.

n. Remove Undergarments (Contaminated).

- (1) Remove the patient's T-shirt.
  - Dip cutting devices in 5 percent hypochlorite solution, scrub them with the M295, or wash thoroughly with soap and water between each cut.
  - Cut around bandages or splints, leaving them in place.
  - Cut up the front (or back) of the patient's T-shirt from the waist up to the collar.
  - Cut both sleeves from the elbow to the shoulder and then to the collar.
  - Next, peel the T-shirt away from the body to avoid spreading contamination.
- (2) Remove the patient's brassiere.
  - Cut it between the cups.
  - Cut both shoulder straps where they attach to the cups and remove the brassiere.
- (3) Remove the patient's under shorts/panties.
  - Cut from the lower side of the hip to the waist on both sides.
  - The decontamination team member places the undergarments into the contaminated trash bag, along with the overgarments and other contaminated items from the patient.

## 14. Wound Decontamination and Trauma Management Procedures

### a. Wound Decontamination.

(1) Only trained medical personnel will change patient bandages, tourniquets, and splints.

(2) During decontamination, the clothing around bandages, tourniquets, and splints is cut and, if possible tourniquets and splints are left in place.

(3) Cloth or other debris in the wound can hold contaminants. If contaminated, irrigate large wounds with sterile water or IV saline solution to dislodge debris and wash out contaminants. Remove the debris using forceps or butyl rubber gloves. Then cover the wounds with a large dressing and plastic if there is a fear of additional contamination getting into the wound.

### b. Trauma Management during Decontamination.

(1) Contaminated tourniquet is replaced only by the medical personnel. The new tourniquets are placed 1 inch proximal to the original tourniquet and then the old, contaminated tourniquet is removed and put in the contaminated waste bag.

(2) Chemically contaminated splints remain in place and are decontaminated with the M291 or saturated to the skin with soapy water to include the padding and cravats. This can be performed by a decontamination team member if supervised by medical personnel. If the splint cannot be saturated (air splint or canvas splint), it must be removed or replaced by the medical personnel to enable everything under it to be decontaminated. Splints will only be removed by a physician or by other medical personnel under the supervision of a physician.

### **WARNING**

**DO NOT apply the M291 or irrigate wounds in the abdominal and thoracic cavities or intracranial (head) injuries. DO NOT remove splints unless permitted by a physician or other medical personnel under the supervision of a physician.**

(3) Intravenous Lines. Removal of IV bags and tubing during decontamination is at the discretion of the medical officer supervising decontamination operations. The IV bags can be wiped down with soap and water if there is a concern about their contamination. The IV lines should be protected during patient litter transfer.

## 15. Establishing a Patient Decontamination Site

### a. Patient Thorough Decontamination.

#### (1) Minimal equipment.

(a) Decontamination of contaminated patients is essential before allowing them into MTFs. The following guidelines should be followed for patient decontamination when minimal decontamination equipment is available. These procedures are most applicable to mobile hospital units who have limited transport capability for carrying decontamination tents and roller systems.

---

Note: Standard Army MESs for decontamination and medical treatment are designed for use with a PDS with minimal equipment. One decontamination MES has

enough supplies to decontaminate 60 individuals. One chemical treatment MES has enough medical supplies to treat 30 patients.

---

(b) The establishment of a PDS should be one of the first priorities once an MTF is established in an area where the threat of CBRN weapons is imminent.

(c) The PDS can be collocated with a troop decontamination unit if adequate medical transportation assets and medical staffing are available.

(d) The PDS can also be located adjacent to the MTF and not collocated with a troop decontamination unit. In this instance the PDS must be located 30 meters or more away from the MTF as wastewater runoff can potentially contaminate the area. If there is an adequate means to collect wastewater runoff, such as the use of a plastic water collection berm and pumps to remove the water, then the PDS facility can be located closer to the MTF.

(2) Roller system.

(a) These procedures are most applicable to stationary hospital units who have an ample water supply. This procedure can be used by mobile units if there is a capability to transport water such as the use of a water tanker and a decontamination roller system if available.

(b) These systems allow for more complete decontamination of patients and help to reduce injury and conserve manpower of decontamination team personnel.

---

Note: This publication does not supersede such documents as AFTTP 3-42.33, USAF CONOPS for In-Place Patient Decontamination Capability, or other specific Service guidance or equipment manufacturer's guidance. It provides supplemental instruction to help streamline processes when this type of equipment is used.

---

b. Preparing the Site Prior To Patient Arrival.

(1) Site selection. The PDS is initially set up in an uncontaminated (clean) area. It only becomes a warm hazard area once contaminated patients begin to arrive. The greatest threats to decontamination team members are from liquid or dry agents on a patient's protective ensemble and from chemical agent vapor that is trapped in clothing and hair or coming from liquid on clothing.

---

Note: Planning and preparation for the establishment of a PDS must take place long before it is to be employed.

---

(2) Select a site that has the following characteristics:

- Access to a road network for easy movement of patients to and from the PDS and for trucks to maneuver dropping off or refilling water bladders, if used.
- Ground that is downhill or slopes away from the MTF or clean side, if possible, for PDS with minimal equipment. For PDS with a roller system, ground is preferably level for tent set-up. The use of water bladders eliminates the need to locate the decontamination system downhill from the MTF.
- Downwind (prevailing winds) from the MTF or clean side.
- In an area where wastewater runoff will not contaminate existing water resources or ground near the MTF.
- Offers adequate security for decontamination personnel.

- Has adequate space to establish a drop-off point with associated warm side triage and treatment areas that can be quickly and easily expanded to handle more than the anticipated number of casualties.
- Large areas, one on the clean side and the other on the dirty, for the staging of dirty and clean patients for evacuation.

c. Staffing of the PDS with Minimal Equipment. The following is the staffing required for one work cycle. More individuals are needed to ensure adequate work/rest cycle rotation. Refer to Table V-5 for suggested information on minimal staffing for one work cycle.

**Table V-5. Suggested Minimal Staffing for One Work Cycle**

<i>Duty</i>	<i>Minimal</i>	<i>Roller System</i>
<b>Command and Control Cell</b>		
Officer in charge.	1	1
Noncommissioned officer in charge. (May also serve as safety officer or another individual can be designated.)	1	1
<b>Entry Control Point</b>		
Entry control point security detail.	2 (optional)	
Augmentees to unload litter patients (2 teams of 4).	8	8 (4 if NATO litter carriers are used)
Security personnel to guard arrival point and perform pat-down search.	2 (optional)	2 (optional)
Road guides and lookouts (night operations).	3 (optional)	3 (optional)
Augmentee trained to use various contamination check tools.		1 (optional)
<b>Triage and Emergency Medical Treatment Area (Warm Side)</b>		
Senior health care NCO or other primary triage officer (PA, nurse).	1	1
Health care specialist to administer treatment.	1	1
Augmentees to serve as litter bearers (2 teams of 4 personnel).	8	
<b>Litter Decontamination Area (Per Litter Lane)</b>		
Augmentees who decontaminate the casualties and perform patient lifts. They wear TAP apron.	4	
Medical personnel.	1	1
Augmentee to clean litters.	1 (optional)	
Clothing removal area of roller system.		2
Body wash area of roller system.		2
Final check area of roller system.		1
<b>Ambulatory Decontamination Area (Per Lane)</b>		
Augmentee to assist patients.	1 (optional)	1 (optional)
Medical personnel.	1	1
<b>Contamination Check Area</b>		
Augmentee trained to use various contamination check tools.	1	
<b>Hot Line Patient Reception (Members on the Clean Side of the Hot Line)</b>		
Augmentees on clean side of the hot line who move litter patient across hot line.	2	2 (1 if NATO litter carriers are used)
Medic on clean side of hot line.	1	1
Total medical	5	5
Total augmentees/others	25–34	14–23
Total personnel for one work cycle	30–39	19–28
<b>Note:</b> This minimal staffing does not include MTF security detail.		

---

Note: At a very small Role I MTF, patient decontamination requires a minimum of eight nonmedical personnel (augmentees) from the supported unit. A dramatically reduced decontamination operation less than the recommendation above may be necessitated. In this instance it is critical to have one or two individuals who can adequately triage, stabilize, and evacuate dirty casualties who cannot be cared for at that facility. Those who can be seen there must have their clothing carefully removed by a team of four augmentees, supervised by a medical personnel. This must be performed before the patient is moved across an improvised hot line. At the hot line, the patient is received by another set of augmentees and a medical personnel wearing MOPP Level 4. Only then is the patient moved inside a clean area where medical staff are not wearing protective ensemble. Contaminated patients must be given adequate decontamination before entering an enclosed area so that unprotected medical personnel are not made ill. The key here will be for the small Role I MTF to reroute contaminated patients to other facilities if they are overwhelmed.

---

d. Establishing a Patient Decontamination Site.

(1) Mark off areas for dirty dump, drop-off point, triage, dirty EMT, litter lane, ambulatory lane, contamination check, hot line, dirty litter decontamination, dirty side shaded rest area, clean side supply, clean side triage and treatment, clean side transport area to MTF, temporary morgue holding area, and patient weapons storage area. The environmental control units (ECUs), water heater, power source, water bladders in a PDS with plumbed tentage can also be marked.

(2) Set up the PDS so that it can be easily marked with chemical lights and negotiated in night conditions. Remove debris along the routes between the dropoff point, triage and treatment areas, and decontamination lanes.

- The *immediate* patients are moved to the warm (dirty) side EMT. This area is located between patient triage (closer to triage to minimize the time it takes to move from triage to dirty EMT) and the entrance to the litter decontamination lanes. This way they can be moved to litter decontamination without interfering with the traffic flow from other patient groups.
- The *delayed* patient area should be positioned nearer to the entrance to both the litter and ambulatory decon lines. This way *delayed* patients can be processed through either the litter or ambulatory lanes when the lanes become available.
- *Minimal* patients should be positioned near the ambulatory patient area so that if medical care on the clean side of the hot line is needed they can process through the ambulatory lane when it becomes available and will not interfere with the flow to the litter lanes.
- *Expectant* patients should be located near the EMT area, but farther away from the decontamination lanes, so that they can be retriaged and stabilized for decontamination if the EMT area no longer has patients in it.

---

Note: More than one patient litter decontamination lane is needed, especially for larger MTFs, as the process takes time and is labor intensive.

---

(3) Establish a security perimeter around the PDS. This should be done by erecting barriers such as concertina wire. Using vehicles as barriers may not be appropriate if access to



these vehicles will be required during patient decontamination operations and the vehicles will be located in the potential warm area of the PDS. These measures will be dictated by METT-TC.

(4) Dig a dirty dump at least 75 meters downwind from the arrival point. The dump should be at least 6 feet deep and large enough to accommodate large numbers of filled contaminated trash bags (one for every two decontaminated patients). The dump should be deep enough so that bags can be covered once the PDS is evacuated or closed down.

---

Note: Preparing a dirty dump while the area is uncontaminated is much easier as workers will not have to assume MOPP Level 4. Once contaminated material is placed in the dump then any expansion of the dump will have to be performed by individuals digging the dump while at MOPP Level 4. It is best to coordinate this with an engineer unit so they can use their earth-moving equipment to dig the holes for dirty dump and construction of wastewater diversion gullies.

---

(5) Dig water runoff gullies (approximately one foot deep) or berms (approximately one foot high) around the litter and ambulatory decontamination areas to trap any water flow and route it away from the decontamination area if plastic berms are not available. These should direct water to a larger pit where wastewater can be collected and if it is a chemical or biological hazard neutralized it with 5 percent hypochlorite slurry.

---

Note: A hard surface area is ideal for the location of a decontamination area as it allows for water runoff without creating a muddy surface; however, these materials (concrete or asphalt) will hold some agents for hours to days. Because of this, a PDS should not be set up on a hard surface road that will be needed later for vehicle movement.

---

(6) Shuffle pits are *NOT* prepared when using a plumbed tent system. With these systems, decontamination team members remain inside the tent during operations so they do not track in contamination from the triage areas. Their boots can also be easily decontaminated inside the tent using the handheld sprayers if necessary.

(7) A PDS with minimal equipment must prepare a shuffle pit at the hot line at the litter patient decontamination line, and another at the ambulatory patient decontamination line or one shuffle pit can be made for both litter and ambulatory lanes.

- Both shuffle pits are located at and should straddle the hot line.
- The litter patient shuffle pit must be large enough to accommodate one litter and four personnel with enough space for them to move around the litter when placed on litter stands located inside the pit.
- The ambulatory shuffle pit must be large enough to accommodate two standing individuals.
- Each pit is dug to a depth of 6 inches. The soil is then returned to the pit and mixed with STB at a ratio of 3 parts soil to 2 parts STB.
- Personnel preparing the STB/soil mixture must assume MOPP Level 4.
- If a boot rinse is used instead of a shuffle pit, then a plastic berm that can contain water is used. It is filled to at least 5 inches deep with a 5 percent hypochlorite solution. It should be replenished every 5 to 10 patients. It should be large enough for decontamination team members to enter and place a litter patient on a pair of litter stands inside the boot rinse area and perform a litter transfer.

- Concertina wire or another barrier should be placed along areas of the hot line that do not include the shuffle pits. The shuffle pits should be the only areas along the hot line where it can be crossed. This will ensure that movement across the hot line is controlled.

(8) It is suggested that only a portion of one MES needs to be moved to the triage area to meet the needs of the number of expected casualties. During operations, additional medical supplies can be moved across the hot line from the clean side supply area as needed. This will reduce the possibility of unused supply items becoming contaminated resulting in their waste. The allocation of decontamination equipment resources is suggested in Tables V-6 through V-8.

(9) In a PDS with minimal equipment, the rest area is established in a shaded area on the warm side of the hot line so PDS workers on the warm side of the hot line can rest, while at MOPP Level 4, without having to process across the hot line.

(10) It is recommended that some type of marking system be incorporated to identify PDS workers. One suggestion is that all decontamination team members have their protective overgarments marked with wide masking tape with their name and team member position clearly marked on their uniform so that they can be readily identified (for example, arrival, triage, security, medical, or decontamination). Instead of tape this can also be done by writing directly on the overgarment if it can be easily seen. Another recommendation is for medical personnel to wear an arm band or have a tape cross on the arm of their overgarment.

(11) Locate water resources, water cans, water buffalo, water bladder, or water tanker with easy access to the decontamination lanes.

(a) In a PDS with minimal equipment, ideal location is to have containers of water that will be used for decontamination located near the warm side rest area. This will reduce any contamination of these containers. Other supplies can be located on the clean side of the hot line in the supply area. Ensure wastewater runoff from the decontamination lanes does not flow toward the water resource area or the medical treatment areas. Water usage can be roughly calculated as follows:

- One patient will require (on the average) 1.5 gallons of soapy water (or 0.5 hypochlorite solution, if used), 1.5 gallons of rinse water, and 2 gallons of water with 5 percent hypochlorite mixture for equipment and decontamination team glove wipe down.
- One patient will require 5 gallons of water (18.92 liters).
- Twenty patients will require 100 gallons (379 liters) of water.

---

Note: When decontamination pails/buckets (12-16 quarts) are filled this is roughly enough liquid for two patients. With every second patient, the liquid that remains in the pails/buckets will be emptied into the garbage bag that contains the cut off garments of the second patient. The pails/buckets are then refilled.

---

- Decontamination using only dry decontaminants, the M291 (SDK) will require 1 to 3 kits per patient as well as IV saline solution for irrigation of wounds.

(b) In a PDS with roller systems, there must be adequate water pressure to operate the water sprayer. Adequate water pressure can only be obtained through the use of water pumps which typically need some type of power source.

(c) Set up the water collection system, tentage, and plumbing as dictated by the manufacturer's instructions. Ensure that there is an adequate way to dispose of wastewater runoff, such as a water bladder, so that it does not contaminate the ground around the decontamination system. A water runoff gully (approximately 1 foot deep) or berm (approximately 1 foot high) can be constructed around wastewater bladders to contain spills. If the runoff water poses a chemical or biological hazard it can be neutralized with 5 percent hypochlorite solution.

---

Note: Test pumps, water flow, soap mixers, water and air heaters to ensure they are operational.

---

(d) To reduce cross-contamination, fresh water and wastewater bladders must *NOT* be positioned next to one another. Ideally they should be on opposite sides of the decontamination tent, with the wastewater bladder downhill from the fresh water bladder and decontamination tent. It is critical that there is an easy access route for a water pumper truck to fill the clean water bladder and a route for a vehicle to pump out the contents of the wastewater bladder or for a forklift to move a specially designed transportable wastewater bladder (if used) to the back of a truck for movement out of the PDS.

(e) Systems that incorporate water sprayers require a large water supply. The supply must provide enough pressure to operate the system. Water pumps are usually required and these require water sources. Ample water supplies are needed for expected number of casualties. A 2,000 gallon water storage container such as a tanker truck or water bladder will allow the decontamination of approximately 200 patients. It is estimated that on the average 10 gallons of water is used per patient with these plumbed systems.

(f) Operators must be aware of the importance of conserving water while still providing adequate decontamination. This will ensure that water supplies are not depleted and wastewater collection systems are not overwhelmed. Water can best be controlled by using hand held sprayers that will allow water flow to be turned off when not in use. Water flow should be adjusted to have moderate-to-low pressure with high flow for brief periods when the sprayer handle is pressed.

(g) Ideally units should incorporate a water heater to increase water temperature and reduce the incidence of patient hypothermia for those undergoing decontamination. Soap mixers can also be added which make dispensing soap from the sprayer possible. This is usually easier than using buckets of soap in the small confines of most tent systems. These heating and soap dispensing units, along with the water pumps, also require a power source.

(h) Collection of contaminated wastewater is critical, especially for biological sporulating agents (anthrax) and radioactive particles. Wastewater collection is also important to limit runoff and ground contamination in the decontamination area, especially if the decontamination tent is close to the MTF. A wastewater bladder is used to collect the runoff. Wastewater is pumped from the collection area of the tent and into the bladder. In cold climates the water and wastewater bladder must be heated to prevent freezing. It is critical that the wastewater bladder be the same size, or larger, than the water storage source. For every patient decontaminated, calculate 10 gallons of wastewater runoff. Wastewater, once collected, is treated with 5 percent hypochlorite solution until chemical hazards are neutralized or biological spores are killed. Radioactive waste can not be diluted in this way. One gallon of water weighs 8 pounds, so a filled 2,000 gallon water bladder will weigh 16,000 pounds (8 tons).

---

Note: Bleach and soap solutions should be prepared in advance during site preparations and should be in sealed containers and clearly marked as to their contents. Five gallon covered water cans or larger jerrycans are ideal for this as they can be carried to a position near the decontamination line and used to refill pails/buckets.

---

**CAUTION**

Hypochlorite solution and soap solutions prepared in storage containers *MUST* be clearly marked as to their contents so that they are not mistaken for drinking water and 5 percent hypochlorite solutions are not confused with soap or water solutions.

(i) Open NATO litter carriers if available. These two wheeled carriers allow two individual to easily move a litter patient. They work well on hard ground but may pose difficulty in sand. Several should be positioned at the drop-off point and at least two at the clean side of the hot line (in the final check area).

(j) When not setting up the decontamination site, augmentees can receive additional JIT training on such topics as: basic medical signs and symptoms of chemical agents; safe patient litter transfer techniques; roles and responsibilities; the use of detection devices (for example, the ICAM, M8 paper, and RADIAC meters as indicated by the threat), the importance of work/rest cycles; and prevention of heat injuries.

(k) Suggested decontamination equipment and supplies distribution for a PDS with minimal equipment.

**Table V-6. Equipment and Supplies Needed for a Decontamination Lane**

<i>Equipment and Supplies</i>	<i>Nonambulatory</i>	<i>Ambulatory</i>
Large trash bags for contaminated waste.	1 box as needed	1 box as needed
Pail/bucket of decontamination, 5 percent hypochlorite solution.	1	1
Pail/bucket of decontamination, soap and water solution (0.5 hypochlorite [least preferred]).	1	1
Bandage scissors or long-handle seat belt cutter with blade replacements (minimum, more are needed as they dull).	4 +	4 +
Self-sealing plastic bags for field medical cards and for personal effects found in outer and inner garments.	1 box of 50	1 box of 50
Sponges.	2+	2+
Decontamination apron (TAP).	4	2
One decontaminable litter for exchange (per patient expected).	2+	
M291 SDK (1 to 3 kits per patient).	1 box	1 box
M295 EDK (1 per patient).	1 box	1 box
Liquid soap (mix in water storage area).	As needed	
Litter stands (pair).	1	1 to steady patients
Supplies to replace bandages, tourniquets, and splints (if necessary).	As anticipated	As anticipated
Optional items not found in decontamination equipment set, but useful.		
Trash can to hold large garbage bags (if transport and storage space available).	1	1
Pail/bucket of rinse water.	1	1
Additional canteens of water for decontamination team members.	4+	4+
3- x 5-inch card and pen (to mark personal effects per patient) or permanent markers to mark outside of personal affects self-sealing plastic bags.	1 box	1 box
Chairs to steady patients while standing.		2
<b>NOTE:</b> Additional quantities of soap and bleach decontamination solutions must be prepared and stored in sealed containers to refill pails/buckets.		

**Table V-7. Equipment and Supplies Required for the Contamination Check Area at a Patient Decontamination Site With Minimal Equipment**

<i>Equipment and Supplies</i>	<i>Per Lane</i>
ICAMs with lithium batteries	2
Spare lithium batteries	8
M8 paper	1 book
M291 for decontamination of small areas	1 box
Bucket of soap and water for small area decontamination	1
Sponge	2

**Table V-8. Equipment and Supplies Required for the Hot Line at a Patient Decontamination Site With Minimal Equipment**

<i>Equipment and Supplies</i>	<i>Per Lane</i>
Large trash bags for contaminated waste	1 box
FMCs (on clean side of hot line)	1 book
Large plastic bag for patient's mask once removed at VCL	1 box
Ballpoint pen (Black) to fill out clean FMC	As needed
STB to replenish shuffle pit	1 container
Optional items not found in decontamination equipment set, but useful	
Blankets (on clean side of hot line)	1 per patient
Trash can to hold large garbage bags (if transport and storage space available)	1

### **16. Actions to Take Upon Notification of Patient Arrival**

a. Immediately upon notification that contaminated patients are to be received, the decontamination team leader or NCOIC will alert the team members.

b. Patient decontamination site OIC/NCOIC will assign augmentees decontamination team their duties and responsibilities at the PDS.

c. All triage, EMT treatment, and decontamination team members assume MOPP Level 2 when the arrival of contaminated casualties is expected, as dictated by the commander. They then assume MOPP Level 4 prior to patient arrival at the ECP. Those who will be decontaminating patients will don their TAP aprons. Mask carriers can be worn or clearly marked with the decontamination team member's name and stored in an organized fashion at the rest area or another location designated by the OIC/NCOIC. Mark protective overgarments with some type of marking system to easily identify PDS workers.

d. Turn on the ICAMs. Once the ICAMs are warmed up, perform confidence checks on each CAM per the technical manual. Activate M22 ACADA if available. It should be positioned at the VCL.

e. All decontamination team members on the warm, (dirty) side of the hot line, as well as those receiving patients on the clean side of the hot line, keep their protective masks on until all patients are decontaminated and the PDS area is determined to be free from hazardous vapors.

### **17. Actions to Take When Contaminated Patients Arrive**

a. Security personnel at the ECP meet transport vehicles and quickly ask the driver as to the numbers and types of casualties and the types of contamination if known. They relay this information by radio to the drop-off point and to PDS OIC/NCOIC. They then direct the vehicle to the drop-off point.

b. Patients are unloaded and whether ambulatory or litter, are given a quick but thorough pat-down search for any ordnance or other explosive devices. The inside of mask carrier can also be checked. Weapons are removed and stored in an area on the dirty side of the hot line. These procedures can be performed by augmentees designated as drop-off point security or by the augmentees who are serving as litter bearers. Suggested pat down steps include—

- Remove the patient's weapons and load bearing equipment/load carrying equipment web gear.
- Check inside the patient's mask carrier for any munitions.

- Try to keep the mask carrier with the patient for triage so that unused antidotes can be administered if nerve agent exposure is suspected or if the patient displays signs and symptoms of nerve agent poisoning.
- Move your hands down the patient's torso while feeling through the overgarment pockets for anything that could be ordnance. If ordnance (ammunition, grenades, magazines, claymore mines) are found, remove them or alert the OIC/NCOIC.
- Do *NOT* remove the patient's protective mask, the patient's personal items at this point, nor remove the patient's identification tags at any time while the patient is in the PDS.
- The contaminated patient is then brought to the warm (dirty) side triage area.

c. At the triage area, the patient is triaged and moved to a treatment area (*immediate, minimal, delayed, expectant, dirty* evacuation) designated by the triage officer. All immediate patients are brought to the dirty EMT area for stabilization.

d. Those patients who need to see the medical providers inside the MTF and are stable enough for decontamination are moved to the decontamination lanes by litter teams or, if ambulatory, directed by an augmentee. The triage officer or EMT treatment officer will direct patient priority for decontamination.

- Patients requiring *minimal* care should remain on the dirty side of the hot line, remain in their protective ensemble, be treated there, and then returned to their unit without going through thorough patient decontamination and crossing the hot line.
- Only those patients needing care at this MTF should go through patient thorough decontamination.
- Patients with physical injury (that prevents them from going through the ambulatory lane) or that are mentally impaired (COSR) are automatically considered litter patients.
- For more information on triage see Chapter III.

## **18. Moving a Litter Patient Through a Patient Decontamination Site**

a. Patient Thorough Decontamination. Decontamination of contaminated patients is essential before allowing them into an MTF. The following guidelines should be followed for patient decontamination:

### (1) Prior to Litter Patient Decontamination.

(a) Any time gross contamination is noted and it needs to be removed as soon as possible. Use any stiff material (such as stick, cardboard, plastic strip, or metal banding strap) to physically remove gross chemical contamination from the patient's protective ensemble. Much of the CW agent contamination can be removed through physical means.

(b) Dusty and dry chemical, biological, and radiological contamination should be carefully dusted or vacuumed (using a vacuum with HEPA filter) from the overgarment. The patient is then moved out of this *dust off* area while still in the protective ensemble. The dust off area must be far downwind from the drop-off point so that dust that might be blown into the air does not contaminate other areas of the PDS. If a manually operated, compressed air sprayer is available, garments can be lightly misted with water to reduce particle aerosolization prior to protective ensemble removal. Caution must be used in this process to not aerosolize the agent with a direct flow of air or water when misting the dry material. Every effort should be made to keep aerosolized dust to a minimum.

(c) The patient is then triaged and moved by litter team to the warm side EMT area. The patient is then medically stabilized (if necessary) by the medical personnel in the area.

(d) Once stable for decontamination, a decontamination team moves the patient to the pair of litter stands in the decontamination area (minimal equipment) or to the ambulatory and nonambulatory patient lane (roller system) decontamination tent.

(e) The patient's litter is placed on the litter stands. Decontamination team members carefully remove the patient's protective ensemble and clothing so that contamination is contained in and on the protective ensemble.

(2) Transferring a Patient to a Litter. The patient's litter is placed on the litter stands. Decontamination team members carefully remove the patient's protective ensemble and clothing so that contamination is contained in and on the protective ensemble.

b. Minimal Equipment.

(1) After the patient's clothing has been cut away, he is transferred to a clean litter. This is either a decontaminable litter or a canvas litter with a plastic sheeting cover.

**CAUTION**

Workers must decontaminate each other's TAP aprons with the M291, M295, soap and water, or 0.5 percent hypochlorite solution before any patient lifting. They must dip their gloves in the 5 percent hypochlorite solution and rinse them with water. This is done as team members stand with arms spread out to the sides, allowing the other team member to get into all the folds of the TAP apron front and sleeves.

(2) The decontamination team members and a dirty side medical personnel decontaminate their gloves and aprons with the appropriate decontamination solution.

(3) One decontamination team member moves to one side of the patient. The medical personnel, if present, moves to the head of the litter. The other three team members move to the other side of the patient. The decontamination team members are wearing butyl rubber TAP aprons or a garment that can be adequately wiped down during patient lifts.

(4) The litter decontamination team members log roll the patient to his side, toward the lone decontamination team member. This technique may need to be modified based on the patient's injuries. Stabilizing the head and neck is particularly critical if some type of spinal injury is suspected. This is done by the following steps.

(a) The individual at the patient's head (preferably the dirty side medical personnel), ensures that his gloves are decontaminated, and places his hands on both sides of the patient's head, with the palms over the ears and fingers to support the patient's jaw to stabilize the patient's head.

(b) The lone decontamination team member crosses the patient's leg, the one that will be on the top when the patient is lying on his side after the log roll. The decontamination team member then places one hand on the patient's shoulder and the other on the patient's hip.

(c) Throughout the log roll, the lone decontamination team member is positioned against the litter to ensure that the patient does not roll forward too far and roll off the litter.



(d) The other three team members help to roll the patient toward the lone member in a controlled, slow manner.

(e) The individual holding the patient's head ensures that the patient's head is turned slightly during the roll, so that it stays in a straight line with the spine.

(5) Once the patient has been log rolled to the side lying position, the three decontamination team members place their forearms on the litter in a *forklift* fashion, each at a different part of the body.

(a) First team member places his forearms to support the patient's shoulders and the waist.

(b) Second team member places his the forearms to support the patient's hip and thighs.

(c) Third team member places his forearms to support the patient's knees and ankles.

(d) The lone decontamination team member then slowly rolls the patient back onto the three decontamination team members forearms. The medical personnel provide supervision and will provide head and neck stabilization.

(6) The decontamination team members lift the patient. Before and during the lift, the individual at the patient's head explains to the patient exactly what is going to happen. The team member who is stabilizing the patient's head gives the command PREPARE TO LIFT. When the three decontamination team members are ready they respond READY. If all team members report that they are ready, the individual at the patient's head then gives the command LIFT. On that command the patient is lifted off of the litter by the three decontamination team members while they roll the patient slightly inwards, against their chests. This lift technique helps to make holding up the patient less of an effort and it best supports the patient. During the lift, the decontamination team members should ensure that they bend at their knees, not at their hips, and try to keep their backs straight and perpendicular to the ground. This will reduce back strain for the lifters.

(7) The lone team member, who is not involved in lifting the patient, takes the dirty litter and the contaminated clothing on it from the litter stands and puts it to the side. He then takes a clean decontaminable litter and places it on the litter stands. If decontaminable litters are not available use plastic sheeting on a clean canvas litter.

(8) The decontamination team member at the patient's head then gives the command PREPARE TO LOWER. If ready, the three team members holding the patient respond READY. The command LOWER is then given and the patient is slowly lowered onto the clean litter.

(9) The cut overgarments and undergarments are placed in the designated contaminated trash bag with the other waste (for example, contaminated bandages) from the patient.

(10) The dirty litter is sent to the litter decontamination area and decontaminated with an M295 or 5 percent hypochlorite solution, allowed to sit for 10 minutes, and then rinsed with clean water. The litter remains on the warm (dirty) side of the hot line and does not cross the hot line, but instead is rotated between the drop-off point and the hot line.

---

Note: Contaminated material from two litter patients can be placed into one 35-gallon trash bag. The remaining 5 percent hypochlorite solution and soapy water (if used) can be poured into the bags. The bag must be tightly secured and transported to the dirty dump.

---

c. Roller System.

(1) Some roller systems are designed to accommodate a standard decontaminable litter or designated to accommodate only a backboard.

(2) If the roller system will accommodate a decontaminable litter, the litter can be placed directly on the roller system. It will be decontaminated as it travels with the patient.

(3) The patient must be transferred to another litter at the end of the decontamination line to ensure that no contamination that could be on the bottom of the litter enters the MTF. The litter is then rotated back through the roller system and washed before used again on the warm side.

(4) If the roller system only accommodates a backboard, the patient must be transferred from his litter to the backboard for movement down the roller system.

(5) The easiest way to transfer the patient from the litter to the backboard involves the following steps:

(a) Position the litter outside the entrance to the decontamination roller system.

(b) Remove the patient's load bearing equipment, mask carrier, and helmet if worn.

(c) Log roll the patient to their side on the litter.

(d) Place the backboard along the back of the patient.

(e) Roll the patient back onto the backboard.

(f) Lift the patient on the backboard and hand the backboard, now containing the patient, to the decontamination personnel at the head of the roller system.

---

Note: When lifting a plastic backboard ensure that staff are holding on to the center handles to keep the backboard from bowing which could cause the patient to fall off.

---

(6) If another transfer technique is used, then it must be one that is easy for the decontamination team members even with the heaviest of patients and one that will not cause further harm to the patient.

---

Note: All transfer techniques should be practiced by the decontamination team using personnel or sand bags. These techniques will have to be modified based on the injuries of the patient.

---

## 19. Clothing Removal Station

a. Once on a litter or the roller system, the patient's mask is decontaminated and clothing is removed as outlined in paragraph 13 above.

---

Note: The patient's mask filter must be covered while undergoing decontamination, especially when using water sprayers. This can be done with a lightly cupped hand or gauze that does not block air flow. Other improvised devices, such as cylindrical containers (such as compact disk 50 disk canisters) can be placed over the filter as long as they do not block air flow.

---

b. Once protective ensemble, boots, clothing, and underwear have been cut off of the patient the patient is rolled to his side. The garments are rolled up to the patient's back. All garments **MUST** be rolled inward so that only the black filter side of the protective ensemble is next to the patient's skin. The patient is then rolled in the opposite direction and the garments are rolled inward and then carefully folded to hold in any contamination. The garments are then passed toward the dirty end of the roller system tent where they are placed in a contaminated trash bag.

c. The decontamination team members who removed the patient's clothing roll the patient along the roller system and then decontaminate their aprons and gloves with soap and water or 0.5 hypochlorite solution.

---

Note: If plumbing and an ample water supply are not available, then the procedures and decontaminants used for field decontamination should be followed as the patient is moved along the roller system. In this case, buckets of soap and water or M291 kits are used.

---

## **20. Decontaminate the Patient**

a. Minimal Equipment.

(1) The patient is now decontaminated with soap and water, M291 decontamination kit, or 0.5 percent hypochlorite solution (least preferred).

(2) If the patient is in full protective ensemble the best method is to decontaminate only those skin areas where there was a break in the ensemble (for example, around wounds, areas where the underlying uniform is wet with agent, or where there is a tear in the overgarment).

(3) If the patient is not wearing protective ensemble or had significant uniform tears, or underlying uniform is damaged, an alternate method is to decontaminate the entire skin surface by wiping the skin with a sponge copious amounts of soapy water with a water rinse.

(4) In the case of a full body wash (litter patient), begin washing the patient from the midline outward, constantly washing, making sure not to place a dirty sponge back on a clean area without first rinsing the sponge. The complete topside of the patient is washed in this manner, paying particular attention to hairy areas of the body (groin and auxiliary regions) and sweaty areas (belt-line, just above the boots, the crease of the buttocks, and wrists).

---

Note: When using 0.5 percent hypochlorite (1/2 percent, dilute household hypochlorite) solution (least preferred), do not do a full body wash. Only decontaminate contaminated areas.

---

(5) Then log roll the patient to his side. With the patient lying on his side, wash the backside of the patient working from the higher areas of the backside and washing down toward the litter. Ensure not to miss any areas. The side of the litter that the patient was rolled away from is then decontaminated prior to rolling the patient onto their back on the litter.

### CAUTION

Log rolling and washing the back of some patients may be difficult and dangerous for the patients depending on their injuries. Procedures will need to be modified in these cases. The supervising medical personnel should be consulted in these cases and should guide the decontamination of these patients closely.

(6) The patient is then moved to their back and now log rolled to their opposite side. Wash the opposite side of the patient in exactly the same manner as above. Decontaminate the litter as above before rolling the patient onto their back on the litter.

(7) After the patient is decontaminated, the medical personnel remove the dressings and replace them if dressings are suspected or found to be contaminated with agent.

### CAUTION

Review guidance for cold weather operations if the ambient temperature is 65°F (18°C) or below.

(8) Superficial wounds are decontaminated and flushed with soapy water.

#### b. Roller System.

(1) After the patient's clothing has been cut away, he is moved down the roller system to the area where the shower hoses dispensing warm soapy water are located. This area is manned by two individuals who spray the patient's body with soapy water and wipe the body using cloths or sponges. They must wipe toward the backboard.

(2) The patient is washed from head-to-toe and then turned on the side so that the patient's back can be washed as well as the top of the litter/backboard.

(3) The patient is then moved along the roller system to the rinse area where the soap is rinsed off of the patient moving from head to toe. The patient is rolled to the side and the patient's back and backboard are rinsed.

---

Note: Water should be conserved as much as possible to reduce the need to refill water storage and reduce the frequency that the wastewater bladder must be emptied.

---

(4) Decontamination team members wash their aprons, gloves, and sponges thoroughly between patients.

(5) Decontamination team members working in these areas should protect their mask filters from moisture as much as possible. Additional filters should be on hand for the staff to change out damp filters. Team members wearing PAPR can keep their filters dry by wearing the blower motor and filters under waterproof aprons to keep filter units dry.

(6) Once the patient is washed and rinsed, the patient is then moved to the *clean* end of the roller system where they are checked for contamination and then dried.

---

Note: Bandages, splints, and tourniquets are only changed by medical personnel.

---

c. Occupational, environmental, and incident exposure data must be documented, recorded, and archived. Reports from OEH or CBRN exposure incidents that result in an acute illness or that have the potential to cause latent illness will be included in the patient records of those individuals affected or possibly exposed. Refer to DODI 6490.03 for more information.

## **21. Check Patient for Completeness of Decontamination**

a. After decontamination, the patient is brought to the contamination check area. The patient is checked with the CAM/ICAM or with M8 detector paper (if patient is fully dry) for completeness of decontamination and checked with appropriate RADIAC meter (preferably one that can detect small areas of alpha and beta contamination) on the body if radioactive contamination is suspected. Other approved monitoring devices may be used when available. There is no detector currently available to measure the completeness of decontamination for biological agents.

---

Note: Decontamination is typically not indicated for biological agents if the person has bathed in the days since initial exposure. If the individual has been exposed to anthrax spores, and has not bathed, then thorough decontamination is important. In this instance, clothing should be carefully removed to reduce the spread of the spores. The skin should be washed with soap and water and runoff water collected/neutralized.

---

b. Dispose of contaminated bandages and coverings by placing them in a designated contaminated waste bag with the contaminated overgarments. Seal the bag and place it in the contaminated dirty dump.

## **22. Movement of the Patient to the Hot Line**

a. Minimal Equipment.

(1) Decontamination team members rinse or wipe down their TAP aprons and gloves with the 0.5 percent hypochlorite solution for chemical and biological agents and soap and water for radiological agents. They then move the patient on the litter to the hot line.

(2) The shuffle pit containing STB is only necessary for chemical agents and sporulating biological agents such as anthrax. They are not necessary for radiological agents although a hot line is still indicated.

(3) At the hot line, a pair of litter stands is positioned inside the shuffle pit. At this point, the patient's clothing has already been cut away; his skin and splints have been decontaminated and contaminated bandages have been replaced. Now the decontamination team members place the patient and litter on the litter stands inside the shuffle pit. The shuffle pit should be wide enough to allow decontamination team members to move around the pit to position the litter inside the pit.

(4) The decontamination team members who brought the patient to the shuffle pit position themselves in the pit around the litter patient on the litter stands. They are still wearing their butyl rubber TAP aprons. If available, the medical personnel from the dirty side accompany the patient to the hot line. Staffing on the clean side of the hot line is made up of at least three reception team members. One of these clean side reception team members must be a medical person (health care specialist/corpsman) and the other two can be augmentees. These members assume MOPP Level 4 but are not wearing TAP aprons.

(5) A member of the decontamination team removes the bagged FMC and holds it so that a medical person on the clean side of the hot line can read it and transfer the information to a clean FMC. After transcribing the information, the clean side medical person attaches the new FMC using the card wire to the patient's mask harness before the patient crosses the hot line to the clean area. The old FMC is disposed of in a trash bag on the dirty side of the hot line.

---

Note: Direct physical contact between the decontamination team and receiving team should be minimized to reduce any risk of cross-contamination.

---

(6) A second litter transfer is performed at the hot line to ensure that no contamination on the litter passes the hot line. Decontamination team members must ensure that they have properly decontaminated their gloves and aprons prior to performing any litter transfer procedures.

(7) The clean side team members stand outside the shuffle pit. The decontamination team members from the dirty side of the hot line position themselves around the patient as they did at the litter patient decontamination area. Two suggested techniques are described below.

(a) The litter transfer can occur as previously described at the litter patient decontamination area. Important points are—

- The clean litter would be provided by staff on the clean side of the hot line and the dirty litter would remain on the dirty side of the hot line and brought to the dirty side litter cleaning area, once it is removed.
- As the patient is lifted, a member of the clean side team places a blanket, if available, on the litter.
- The patient is then laid on the blanket and wrapped in it. The blanket is used to warm the patient.

(b) Once the litter transfer is completed by the decontamination team, they step out of the shuffle pit. Then members from the receiving team, on the clean side of the hot line, step in to the shuffle pit and move the patient and litter to the clean side triage area or into the MTF. Now that their job is done, the decontamination team members drink water from their canteens (while remaining in MOPP Level 4) and move back to the litter lane. If a rest break is indicated they do not go across the hot line to the clean side, but instead they report to the warm side rest area and remain in full ensemble. Once rested, the decontamination team members are rotated back to the litter decontamination area.

---

Note: Before decontaminating another patient, each decontamination team member drinks approximately one-half quart of water. The exact amount of water consumed is increased or decreased according to the temperature but should not exceed 12 quarts a day.

---

#### b. Roller System.

Once decontaminated, the patient is transferred from the roller system litter or backboard to a clean litter at the hot line. The roller system litter is then sent back through the decontamination tent and washed down. Once on the clean litter, the patient is moved to the MTF or to a clean ambulance.

---

Note: Potentially contaminated backboards and litters must be rotated on the dirty side of the hot line. Clean litters are rotated and remain on the clean side of the hot line.

---

## 23. Movement of the Patient on the Clean Side of the Hot Line

### a. Minimal Equipment.

(1) The patient's mask remains on the patient until he crosses the VCL where there is no vapor hazard.

(2) The patient is moved by the reception team to the treatment and triage area on the clean side of the hot line. They are then moved to a clean ambulance for transport to the MTF or carried directly into the MTF if the decontamination line is collocated with the MTF.

(3) A litter decontamination area is established on the dirty side of the hot line. Dirty litters are rotated for use on the dirty side only and are not brought across the hot line to the clean side. Clean-side litters do not need to be decontaminated as they are only rotated on the clean side of the hot line.

(4) In the event of CW or BW agent contamination, augmentees decontaminate decontaminable (plastic mesh) litters by scrubbing with a 5 percent hypochlorite solution over the entire surface of the litter, including the handles. They then should allow the litter to dry for 10 minutes and then rinse it with water. This wait time will allow the solution to neutralize any chemical agent on the litter.

(5) If canvas litters are used, the augmentees will remove any barrier materials (plastic sheeting) used to protect the wooden handles and canvas cover and place these materials in a contaminated trash bag. If the barrier material is in short supply, the plastic sheeting can be scrubbed with 5 percent hypochlorite solution, allowed to dry for 10 minutes, and then rinsed with water. The canvas litter handles will be wiped with a 5 percent hypochlorite solution. Do not use the hypochlorite solution directly on the canvas as it will destroy the material. Contaminated canvas litters cannot be thoroughly decontaminated as the wood and canvas will absorb chemical agents.

(6) When not decontaminating a litter, two of the augmentees will transport the contaminated waste to the dirty dump.

### b. Roller System.

(1) Once the decontamination process is complete and the patient is transferred to a clean litter, the patient is then moved across the hot line. The hot line is located at or near the clean end of the roller system.

(2) A shuffle pit is *NOT* required for a roller system as team members remain at their roller system stations and are not traveling from the triage area to the hot line.

---

Note: The decontamination team members assume MOPP Level 4 or OSHA Level C with protective aprons to keep the protective ensemble dry during decontamination. They remain on the dirty side of the hot line and do not cross to the clean side of the hot line unless their protective overgarments are removed. The receiving team members also wear MOPP Level 4 or OSHA Level C but they do not wear protective aprons. Direct physical contact between the decontamination team and receiving team should be minimized to further reduce any risk of cross-contamination.

---

## 24. Moving an Ambulatory Patient Through Patient Decontamination

a. The step-by-step procedure outlined below is the prescribed procedures for decontaminating an ambulatory patient, but it is by no means the only method. Following this

procedure ensures that the correct steps are not omitted. The focus must be to carefully remove the overgarment so that any cross-contamination from the protective ensemble to the patient's skin is prevented.

b. Minimal Equipment.

(1) The M291 SDK or a soap and water solution are used for chemical decontamination on the skin. The least desired alternative for skin decontamination is 0.5 percent hypochlorite solution. The 0.5 percent hypochlorite solution if used for skin decontamination will irritate and burn the skin, allowing agents to enter the skin more rapidly.

(2) The M295 Individual EDK is used to remove obvious contamination from the protective ensemble and equipment and to help to control the spread of contamination from it to other areas. If it is not available, then either soap and water solution, 5 percent hypochlorite solution or a field-expedient adsorbent material, such as clean dry earth or flour, can be substituted.

c. Roller System.

(1) Soap and water is the decontaminant used in a shower based decontamination system. The M295 or 5 percent hypochlorite solution can be used to decontaminate the mask prior to overgarment removal.

(2) The shower line is composed of three stations:

- Undressing area.
- Shower area.
- Final check area (contamination levels can be checked depending on particular Service policy. In this area, the patient dries himself and dons a disposable garment, blanket, or sheet).

(3) Minimal staffing is required for the ambulatory patient line as the patients can usually assist one another. A minimum of one medical person is needed to help those with medical conditions and an augmentee to direct traffic flow.

(4) Patients are directed through the process and are observed by the medical personnel or augmentee to ensure that they wash from the head down, cleaning all areas of their body, and spending approximately 2 to 5 minutes washing.

(5) Patient time in the showers should be limited to 5 minutes to conserve water and limit wastewater volume as it must be collected in the wastewater bladder.

d. Prior to Ambulatory Patient Decontamination

(1) Physically remove gross contamination.

(a) Use any stiff material (such as stick, cardboard, plastic strip, or metal banding strap) to physically remove gross chemical contamination from the patient's protective ensemble. Much of the CW agent contamination can be removed through physical means.

(b) Dusty chemicals and dry biological and radiological contamination should carefully be dusted or vacuumed (using a vacuum with a HEPA filter, if available) from the overgarment. The patient is then moved out of this *dust off* area while still in the protective ensemble. The *dust off* area must be far downwind from the drop-off point so that dust that might be blown into the air does not contaminate other areas of the PDS. Every effort should be made to keep aerosolized dust to a minimum.

(2) The patient is then directed to the triage area where triage is performed.



(3) From the triage area, the patient is directed to the appropriate warm-side medical treatment area. Once treated the patient may be returned to his unit without undergoing decontamination, moved to the dirty evacuation area, or directed to the ambulatory lane of the PDS/decontamination tent if further treatment is required on the clean side of the hot line at this particular MTF. If directed to the ambulatory lane the patient will move to that lane and await clothing removal and decontamination.

## **25. Processing Through the Ambulatory Decontamination Line**

### **a. Minimal Equipment.**

(1) Remove mask hood, overgarment, and overboots.

(2) Replace any contaminated bandages and tourniquets. This is only performed by a medical personnel (health care specialist/corpsman or medical provider).

(3) At this time (the patient is only wearing combat boots and protective mask), the patient is monitored for contamination. Use ICAM or M8 detection paper to monitor for chemical agents and a RADIAC meter for radiological contaminants. Check all areas of the patient's body, mask and combat boots. Pay particular attention to—

- Combat boots.
- Protective mask.
- Bandages and splints.
- Hair and neck area.
- Wrist and ankle areas.

(4) If no contamination is found then send the patient to the hot line.

(5) If contaminated skin areas are found then decontaminate using the M291 or soap and water.

(6) Check all personal items that were removed from the patient and placed in a self-sealing plastic bag by using the appropriate detector inside the bag opening. If the items are not contaminated, have the patient bring them through the decontamination line. If they are contaminated then ensure that the bag is marked with the patient's name and the bag and its contents are placed in a secure holding area for decontamination or proper disposal.

---

Note: The patient remains in his protective mask until he cross the VCL.

---

### **b. Movement Across the Hot Line.**

(1) Process the patient as quickly as possible across the hot line.

(2) The augmentee instructs the patient to move across the shuffle pit/hot line.

(3) The patient shuffles/moves through the shuffle pit wearing his combat boots.

---

Note: The ambulatory patient shuffle pit should be wide enough for the ambulatory patient and one augmentee.

---

(4) An augmentee from the clean side meets the patient and opens a blanket or other covering for the patient (appropriate for the environmental conditions). Once across the VCL the ambulatory patient removes his mask.

(5) In the clean treatment area, the patient is retriaged, treated, and evacuated.

---

Note: In a hot climate, the patient will probably be significantly dehydrated; the rehydration process must begin immediately.

---

(6) Overhead cover should be provided for casualties in the clean-side holding area.

c. Roller System.

(1) Actions in the undressing area. Patient undressing can be performed just outside the ambulatory lane of the shower tent if adequate room is not available inside the tent.

(a) The patient's mask is decontaminated, but remains on the patient. The filter inlet should be covered lightly to prevent moisture from entering the filter canister.

(b) The patient's overgarments (to include boots) and undergarments are cut-off or removed and placed in a contaminated trash bag located near the entrance to the tent.

(c) Once nude but still masked, the patient is directed to the shower area.

(2) Actions in the shower area.

(a) The patient enters the shower area with no clothes or boots/shoes on.

(b) The patient is given a maximum of 5 minutes to thoroughly wash and rinse his body.

(c) The patient is directed to soap up their body, starting with the hair. They must bend his head forward so that runoff water from his hair does not get in the eyes. They then soap and wash quickly from head to foot (approximately 3 minutes) including skin folds such as the arm pits and groin. If available they should be given a paper wash cloth or sponge to help scrub the body.

(d) The patient is then directed to rinse (approximately 2 minutes).

---

Note: Replacement of any contaminated bandages and tourniquets is only performed by medical personnel (health care specialist/corpsman or medical provider).

---

d. Actions in the Final Check Area.

(1) After washing and rinsing, the patient moves to the final check area in the tent. Depending on the particular Service CONOPS, the patient can be checked for thoroughness of decontamination using an ICAM or M8 paper for chemical exposure or a RADIAC meter for radioactive particle exposure.

(2) Once washed and rinsed, the patient is given assistance to dry if they are having difficulty. They can then don a disposable garment, blanket, or sheet.

(3) If time allows, check all personal items that were removed from the patient and placed in a self-sealing plastic bag. This is performed by using the appropriate detector inside the bag opening. If the items are not contaminated, have the patient bring them through the decontamination line. If they are contaminated ensure that the bag is marked with the patient's name and they are placed in a secure holding area for decontamination or proper disposal.

(4) A member of the decontamination team removes the bagged and holds it so that a medical person on the clean side of the hot line can read it and transfer the information to a clean FMC. Information such as type of injury, treatment given, or time/type of exposure must be transcribed to the clean FMC. After transcribing the information, the clean side medical personnel attaches the new FMC using the card wire to the patient's mask harness before the

patient crosses the hot line to the clean area. The old FMC is disposed of in a contaminated trash bag on the dirty side of the hot line.

---

Note: The patient remains in their protective mask until they cross the VCL which is located outside of the decontamination tent and beyond the hot line.

---

(5) A decontamination team member instructs the patient to move out of the tent and across the hot line (which is located at the immediate rear of the tent). With a shower system, a shuffle pit is not needed as contamination is contained within the tent.

## **26. Procedures for Closing Down a Patient Decontamination Site**

a. Once all patients have been processed through the PDS, the OIC will direct the team members to close down the PDS or disestablish it if it needs to be moved to a new location. The closure of the PDS will pose challenges due, in large part, to the fatigued condition of the PDS personnel. During PDS closure, it is critical that PDS personnel maintain adequate water intake so that workers do not become dehydrated.

b. Medical team members from the triage area will begin PDS closure procedures first, as their portion of the process ends first. They consolidate unused, but uncontaminated, medical supplies and place them in their appropriate containers/boxes. These must be checked with the appropriate monitoring device before consolidation so that other supplies are not cross-contaminated. All waste materials are placed in contaminated trash bags and sealed by double knotting the necks of the bags. The bags are then transported to the dirty dump. The drop-off point personnel will also assist with this effort. Any contaminated medical supplies that cannot be decontaminated will be placed in the contaminated trash bags and discarded in the dump.

c. Supplies and equipment that can be decontaminated will be sent through the decontamination line either on a backboard or litter. If the PDS is not going to be relocated, these items can be stored in the shade on the warm side of the hot line after they have been decontaminated.

d. All cutting devices are allowed to sit in a bucket of 5 percent hypochlorite solution (if chemical or biological agents were encountered) for 30 minutes and then rinsed thoroughly if they are to be reused. If radiological contamination was encountered, cutting tools only need to be rinsed thoroughly. Blades are then replaced if they are to be reused. Dull bandage scissors or other cutting devices are bagged with other waste and sent to the dirty dump.

e. Any weapons or patient personal effects which have not been decontaminated by this time are decontaminated, checked for contamination, and passed across the hot line. Personal effects that can not be decontaminated, such as paper items, are also placed in the contaminated trash bags and disposed of in the dirty dump.

f. Once all supplies and equipment have been stored and washed then the inside walls of the roller system decontamination tent should be sprayed down with soapy water and then rinsed.

g. Arrangements are made to have the water containers topped off and the wastewater containment neutralized and emptied or properly disposed of.

h. See Table V-9 for equipment needed for the closure of a PDS.

**Table V-9. Equipment and Supplies Required for the Closure/Disestablishment of a Patient Decontamination Site**

<i>Equipment and Supplies</i>	<i>Per Lane</i>	<i>Per Lane</i>
	<i>Minimal</i>	<i>Roller System</i>
Large trash bags for contaminated waste	As needed	As needed
A slurry mixture of STB or a 5 percent hypochlorite (full strength household liquid bleach) solution (in buckets)	As needed	
Pails/buckets for STB slurry or hypochlorite solution	2 to 4	2 to 4
Pails/buckets for rinse water	2 to 4	
Sponges or rags	2 or more as needed	
Butyl rubber TAP aprons	As needed	
Entrenching tools	2 to 4	

## 27. Equipment and Supply Recovery

a. If the agent was chemical or biological, prepare the STB slurry mixture or 5 percent hypochlorite solution and place them in pails/buckets. The STB is prepared with four parts STB to 6 parts water (by weight). For example, 6 parts of water weighs 42 pounds (1 gallon weighs 8 pounds) and mixed with 28 pounds of STB, provides the required slurry mixture. If the agent was radiological then a soap and water mixture is more appropriate.

b. If the PDS is to be disestablished and moved to another area, then move all large equipment to an equipment decontamination area about 50 meters to the side of the decontamination lanes.

c. If the PDS is to remain in the same place, then keep equipment except for high value items such as the ICAMs and medical supplies in place and scrub them down in place. They must also be checked to ensure they are free from contamination.

d. The STB slurry or 5 percent hypochlorite solution is allowed to remain in contact with the equipment for 30 minutes. After 30 minutes the items are then flushed with clean water. For radiological contamination no wait time is required and soap and water is used.

e. After each item has been scrubbed and flushed, then it is checked carefully with the appropriate monitoring device. No detector is yet available that will give rapid enough results so that the site can be closed within a short amount of time. The surface of these items should be monitored with special attention to cracks, joints and seams, bolts, porous material, and any openings in the equipment.

f. While waiting for the 30 minute contact time to occur, do the following tasks:

(1) All waste items (for example, contaminated medical supplies, dirty bandages, garments cut off the patients, patient mask carriers, used sponges, dull scissors and cutting blades) are placed in contaminated trash bags and taken to the dirty dump.

(2) Unused, uncontaminated, medical supplies are monitored for contamination and if clean are placed into a covered or metal container. The outside of the container is decontaminated and rinsed. These are then positioned for movement across the hot line when determined to be free of contamination.

(3) Any items in the weapons and contaminated personal effects storage area are decontaminated and moved across the hot line. Personal effects that cannot be decontaminated, such as paper items, are disposed of in the dirty dump.

(4) In the PDS with minimal equipment, the shuffle pits are camouflaged and covered with dirt.

(5) The dirty dump is backfilled with dirt. A small section of the dump is left open for disposal of bagged PDS personnel overgarments. The dump is marked with the NATO CBRN marking set.

(6) Personnel conduct a thorough police call of the PDS area.

---

Note: A thorough police call, camouflage, and clean up is conducted to reduce hazards.

---

g. Movement of Equipment Across the Hot Line. Any equipment or supply item that is to be passed across the hot line to the clean side must be checked for contamination using the appropriate monitors.

## **28. Decontamination Team Personnel Recovery (Technical Decontamination)**

a. Technical decontamination refers to the deliberate decontamination of responders/PDS personnel and their equipment. Technical decontamination is conducted with the emphasis on deactivation/neutralization of the agent with speed not being a factor. Terms that are commonly associated with technical decontamination are detailed, deliberate, and responder decontamination.

b. Once equipment and supply recovery is accomplished, then all PDS personnel will conduct technical decontamination, except for two individuals.

---

Note: It is strongly suggested that the remaining two individuals be detailed from those who have been working on the clean side of the hot line.

---

c. The PDS NCOIC/OIC will select a technical decontamination location/station.

d. All PDS detailed personnel will perform technical decontamination and the two remaining personnel will put all discarded protective overgarments, gloves, liners, and boots into designated contaminated trash bags and place them in the dirty dump. If possible, boots should be decontaminated and reused.

e. Once items have been placed in the dump, the two remaining individuals will complete back fill or complete camouflage of the dirty dump and complete marking of the dump with the NATO CBRN marking set. They will then move back to the hot line and perform technical decontamination. Their sets of protective ensemble are placed in contaminated trash bags and left in place and camouflaged. If the site is to be used later, then the next team to operate it can place these two discarded protective ensembles in the dirty dump.

f. Higher headquarters must be notified of the location of the dirty dump. This can be done through a CBRN 5 report. Every effort should be made to have engineers in protective ensemble to cover the dirty dump using their heavy equipment if the PDS is relocating or the dump is full and a new one needs to be dug. The area must be marked so friendly forces will not use it and if the tactical situation allows, it should be guarded to prevent local nationals from scavenging the dirty dump.

## 29. Establishing a Patient Decontamination Station on a Water Vessel

a. General. This paragraph specifies the procedures for receiving, decontaminating, and monitoring limited numbers of patients who have been exposed to CBRN agents and are transferred to naval vessels or hospital ships (T-AH). Information is compiled from NTTP 3-20.31.470 and FM 3-11.5/MCWP 3-37.3/NTTP 3-11.26/AFTTP[I] 3-2.60.

b. Shipboard Decontamination of Ground Force Personnel. In general, the best approach to decontaminating contaminated ground force personnel is to provide them support and a suitable location to execute their standard change out procedures either on land before transport to the ship or, if they arrive *dirty* to decontaminate them on the deck of the ship. Ideally, patient should be thoroughly decontaminated before they are transported to a ship, but this may not always be the case. Patients may be evacuated *dirty* by water or rotary-wing aircraft after undergoing only operational decontamination. It is assumed that the steps of gross decontamination to remove liquid or solid contamination (patient operational decontamination) have been applied before casualties are transported to a naval vessel.

### WARNING

**Immediate (gross) and operational decontamination procedures for contaminated ground force personnel are not adequate to allow them to enter inside the ship. Individuals must have undergone thorough decontamination.**

c. The PDS acts as a transition area, allowing clothing removal, skin decontamination and chemical agent monitoring to take place in the controlled environment of the ship without releasing contaminants into the ship's ventilation system.

d. Ship Ventilation Consideration.

(1) Ship's course. To receive contaminated patients, the ship will steer into the wind, as normally occurs during helicopter operations. This is necessary because the main air intakes of the ship's ventilation system are not filtered and are forward of areas where decontamination will occur.

(2) Oxygen generation station. Compressors in the oxygen generation station, located immediately aft of the flight deck, must be turned off during the decontamination operation and remain off for a period of one-half hour after the decontamination operations end. The ventilation system of the flight deck decontamination station maintains the entry passageway at a negative pressure and provides a flow of clean air from the elevator passageway, through the decontamination compartments, and out an exhaust fan in the entry passageway. The vents are sized for proper flow velocity to prevent the release of airborne contaminants to the rest of the ship.

(3) Airflow rate. The airflow rate of the ventilation system produces one air change every 1.5 minutes in each compartment, so airborne contaminants will be purged rapidly, preventing release of contaminants to the staging area when doors are opened for moving patients.

### **WARNING**

**The exhaust fan overhead in the passageway must be operating for decontamination operations and for using the shipboard PDS for screening/holding patients who may have infectious diseases. The airflow induced by this fan is critical to contamination containment. This fan is not used during other operations.**

e. Control of doors. At no time should two doors of the same compartment be opened simultaneously, nor should the forward and aft doors of the airlock in the entry passageway be opened simultaneously when processing contaminated patients. Failing to observe this precaution will result in an interruption of the airflow and possible release of contaminants. Doors leading into the elevator passageway are controlled by the decontamination team in the compartments adjacent to the passageway and should be opened only when the chemical monitor (that is, ICAM) indicates it is safe to do so.

f. Dwell Time in Compartments. The compartments are designed for a residence time of 10 minutes; that is, the time between closing the first door and opening the second door of each compartment should be 10 minutes when contaminated patients are being processed.

g. Communication. Doors should be opened only for movement of patients. Communication among the compartments should be made with radios, an intercom system, or by writing notes (such as a grease pencil on writing board) visible through the windows between compartments.

h. Monitoring of contamination. The ICAM is employed in the monitoring station to ensure that the patient is free of chemical contaminants when ready to go inside the ship. A secondary use of the ICAM is to monitor decontamination team personnel, equipment, and the area of the flight deck used for decontamination after the processing is completed. A RADIAC meter with a pancake probe is used to monitor patients potentially contaminated with radioactive particles. There is currently no device available to readily monitor biological contaminants.

i. Heat stress. The decontamination team members must recognize the potential for heat injury when wearing their protective clothing for extended periods. Compartments may become warm during decontamination operations and the team leader must ensure that members drink liquids before, during, and after the operations. Canteens or camelbacks with drink tubes should be placed in the compartments to allow team members to drink through the mask during the operations.

## **30. Actions to Take Prior to Arrival of Patients**

a. Prepare the Ship for Receiving Contaminated Patients.

(1) Immediately upon notification that contaminated patients are to be received, the chemical, biological, and radiological defense (CBRD) coordinator will activate the ventilation system of the shipboard PDS and ensure that general ship preparations are being made for receipt of contaminated patients (windward direction and securing the oxygen generation station).

(2) The ventilation system of the PDS is activated by turning on the switch near the forward end of the passageway. The exhaust fan is located overhead in this passageway and

the fire damper for the fan must be in the open position for air to be drawn through the decontamination station. This should be checked visually by examining the fan. Excessive noise of the fan is an indication that the fire damper is in the wrong (closed) position. Other preparations of the decontamination facility are as follows:

- Check the elevator passageway, to ensure the spool piece is removed and blanks are mounted in the exhaust system overhead. The ceiling panels normally conceal this duct.
- Close the fire damper in the elevator passageway exhaust system 03-37-1. Open the fire damper and the watertight closure for the natural supply duct.
- Ensure that the dampers (three total) located in the vents between each set of compartments are open. These are located in the centerline bulkhead of the decontamination station, about 5 feet above the floor. The damper handles are located in the elevator passageway on the portside bulkhead.
- Check to ensure that supplies and equipment specified below are available in each compartment.
- Check that floor drains in the decontamination compartments are open and unclogged.
- Close all doors of the decontamination station.

b. Prepare Supplies and Equipment.

(1) Chemical agent monitors. Turn on the ICAMs in each of the three monitoring compartments if the agent is unknown or chemical agent contamination is suspected. These are to be operated on alternating current and will have four batteries in each of the D-cell adapters to which the alternating current power is connected. Once the ICAMs are warmed up, perform confidence checks on each ICAM per the technical manual.

(2) Decontaminant. Prepare pails/buckets of decontaminant. Each station will have pails/buckets filled with 5 percent hypochlorite (full strength household liquid bleach) solution (for cutting tools and to wipe down equipment) or soap and water mixture (to use on patient's skin). The pails/buckets must be color coded (for example, orange or red for hypochlorite mixtures and a more subtle color for the soap and water mixture). This will help team members to distinguish the contents. The pails/buckets of the two solutions should be allocated as follows:

- Flight deck. Two pails/buckets per station/one 5 percent and one soap and water (maximum 6 pails).
- Skin decontamination compartment. Two pails/buckets per compartment—one 5 percent and one soap and water.
- Monitoring compartment. One pail/bucket per compartment—soap and water solution.

(3) Supplies for flight deck: Position the supplies and equipment inside the entry passageway. It will not be taken onto the flight deck until the flight deck director so directs. There are two types of cutting instruments that should be used: the V-Blade Safety Rescue Knife (National Stock Number [NSN] 5110-00-524-6924) or similar long handled seat belt cutting tool will be used for rapidly cutting most areas of the garments. The blades of these knives should be checked for sharpness before the operation and be replaced as necessary. The bandage scissors will be used to cut shoelaces, hoods, and other areas not appropriate for the V-blade knife. The team leader will ensure that these supplies and those listed for each compartment are in place.



(4) Wet the flight deck: To minimize the possibility of agent absorption into the surface of the flight deck, prewet the flight deck (from the entrance of the decontamination station to 15 feet aft of the yellow line) with the fire hose 5 to 10 minutes before the contaminated patients arrive by helicopter.

c. Prepare the Decontamination Team and Flight Deck Personnel.

(1) Overgarments and protective masks of the decontamination team should be stored in a readily accessible area and should be marked with the name of each team member for rapid access.

(2) The flight deck personnel will wear the protective mask and protective gloves when supporting the landing and takeoff of the helicopter and when transporting the patient to the deck area forward of the yellow line.

(3) Decontamination team members will be fully dressed in their protective ensemble (MOPP Level 4) by the time the helicopter lands on the deck or a water vessel carrying contaminated casualties docks with the ship. Those who are to perform procedures on the flight deck will wait in the entry passageway. Mask carriers will not be worn but will be left inside the decontamination station. All personnel will wear voice amplifiers on their protective masks. They will check that each amplifier has a working battery installed before operations begin.

(4) The CBRD coordinator or his designee will check each team member to ensure that the mask and protective clothing are donned and fitted properly.

(5) The medical director of decontamination and the CBRD coordinator each will wear a white band with red cross on the left arm. Each team member will wear a strip of tape on the front of the uniform with his name marked on it.

(6) All other ship's personnel will remain inside enclosed areas of the ship during and for one half hour after the end of decontamination operations.

(7) When not setting up the decontamination site, team members can receive additional *hip pocket* or JIT training on such topics as: basic medical signs and symptoms of chemical agents; safe patient litter transfer techniques; roles and responsibilities; the use of detection devices (for example, the ICAM, M8 paper, and RADIAC meters as indicated by the threat); correct litter patient lift techniques; the importance of work/rest cycles; and prevention of heat injuries.

d. Staffing for PDS on a water vessel. Table V-10 is an example of minimal staffing for one work cycle at a PDS on a water vessel. More individuals are needed to ensure adequate work/rest cycle rotation.

**Table V-10. Minimal Staffing for One Work Cycle at a Patient Decontamination Site on a Water Vessel**

<i>Job</i>	<i>Per Lane</i>	<i>For Three Lanes</i>
<b>Command and Control Cell</b>		
Officer in charge.	1	1
Master-at-arms (May also serve as safety officer, or another individual can be designated. The master-at-arms also performs pat-down search and secures ordnance, and personal affects.)	1	1
<b>On Deck Arrival Point</b>		
Augmentees to remove litters (1 team of 4).	4	12
Primary triage officer (physician, PA, nurse, or senior corpsman).	1	1
Corpsman to administer treatment.	1	3
Augmentees to perform protective overgarment cut-off procedures. They wear TAP aprons.	2	6
<b>First Compartment Decontamination Area</b>		
Augmentees who cut off underclothing and decontaminate the patient. They wear TAP aprons.	4	12
Corpsman.	1	3
<b>Second Compartment Contamination Check Area</b>		
Augmentee trained to use various contamination check tools.	1	3
Corpsman.	1	3
<b>Hot Line Patient Reception</b>		
Augmentees to move litter patient out of second compartment across hot line.	2	6
Corpsman on clean side of hot line outside second compartment.	1	3
<b>Total Medical</b>	5	13
<b>Total Augmentees, Others</b>	15	41
<b>Total Personnel For One Work Cycle</b>	20	54

### **31. Procedures to be Performed on the Flight Deck**

a. Equipment should be staged in the entry passageway. When the helicopter landing operation is complete and the patients have been checked for ordnance, take the equipment onto the flight deck and position the pails/buckets of decontamination solution containing scissors and long handled seat belt cutters at the yellow line near the entrance to the decontamination station. (Up to three stations are set up, one station for each patient requiring decontamination, so that three patients can be processed simultaneously.)

b. Tables V-11 and V-12 list recommended quantities of equipment and supplies required for each compartment of the shipboard decontamination process.

**Table V-11. Equipment and Supplies Required for Patient Decontamination Procedures Conducted on the Flight Deck**

<i>Equipment and Supplies</i>	<i>Per Lane</i>	<i>For Three Lanes</i>
Trash can with trash bag insert (extra bags placed beneath first bag).	1	3
Pail/bucket of decontamination (5 percent hypochlorite solution).	1	3
Pail/bucket of decontamination (soap and water solution).	1	3
Bandage scissors.	4	12
Long-handled seat belt cutter (minimum, more are needed as they dull).	2	6
Self-sealing plastic bags for FMC.	2	6
Sponges.	2	6
Decontamination apron (TAP).	4	12
Canteens of water (in passageway).	4	12
One decontaminable litter for exchange.	1	3
3- x 5-inch card and pen (to mark personal effects).	3	9
Self-sealing plastic bag for FMC and for personal effects found in outer garments.	6	18
Fire hose, 1.5-inch diameter, multipurpose nozzle.	1	1

**Table V-12. Equipment and Supplies Required for Patient Decontamination Procedures Conducted in First Compartment**

<i>Equipment and Supplies</i>	<i>Per Lane</i>	<i>For Three Lanes</i>
Trash can with trash bag insert (extra bags placed beneath first bag).	1	3
Pail/bucket of decontamination (5 percent hypochlorite [full strength household liquid bleach] solution).	1	3
Pail/bucket of decontamination (soap and water) solution.	1	3
Containers of bleach.	2	6
Measuring cup for dilution of bleach.	1	3
Bandage scissors (minimum, more are needed as they dull).	2	6
Long-handled seat belt cutter (minimum, more are needed as they dull).	2	6
Self-sealing plastic bags (box) for FMC.	2	6
Sponges.	2	6
Decontamination apron (TAP).	4	12
Self-sealing plastic bags (for personal effects).	One per Patient	
Canteens of water (in compartment).	4	12
Sharps container.	1	3
Pad of paper and ballpoint pen.	1	3
Clock or timer for 10 minute dwell time.	1	3
Felt marker/grease pencil with writing board (for communicating through window).	1	3

## 32. Moving a Litter Patient Through a Patient Decontamination Station on a Water Vessel

a. Contaminated patients are initially processed in the open air of the flight deck where they are triaged and outer clothing is removed. The patients are then brought to the first compartment where inner clothing is removed and decontamination takes place. They are then taken to the second compartment where contamination monitoring is performed and the patient is brought inside the ship. There are three pairs of decontamination compartments (three parallel lanes) that allow up to three patients to be processed concurrently.

b. The flight deck personnel carry the patient from the helicopter across the yellow line and secure the litter on the deck. They return a folded clean litter (obtained from the ramp area) to the helicopter immediately, leaving the contaminated litter to be decontaminated and retained on the ship.

c. The master-at-arms removes all battle dress items, ordnance, and weapons. Weapons should be secured outside the skin of the ship or within the entry passageway of the decontamination station until they can be monitored to determine that they are free of contamination.

d. The medical officer performs triage once ordnance is cleared. All procedures on the flight deck are done with litters resting on the deck. Litter stands will *NOT* be used.

e. On Deck Procedures Removing the Litter Patient's Protective Ensemble.

(1) Clothing removal procedures are based upon the assumption that patients arrive on ship wearing protective mask, overgarment, gloves, and overboots.

---

Note: If the patient does not have a complete protective ensemble, the processing will be performed in the same order specified: removal of outer layer of clothing followed by inner layer of clothing. If the patient has no protective mask, he should be positioned with his head toward the bow of the ship, into the wind, while his clothing is removed on the flight deck.

---

(2) Remove the patient's personal articles from pockets. Place all items in a plastic bag for later decontamination or destruction. Label the bags with the patient's name and social security number (information will be written on a 3- x 5-inch card or piece of paper and then the card will be placed into the plastic bag). Seal the bags then wipe with 5 percent hypochlorite solution. They will then be secured in an area outside the skin of the ship until the items can be decontaminated in a 5 percent hypochlorite solution, rinsed, dried and checked for contamination. Nondecontaminable items will be inventoried and destroyed. Decontaminated items that are contamination free will be bagged and returned to the patient.

(3) Remove mask hood (if worn) and outer protective ensemble garments for litter patients as outlined in paragraph 13 above. Then perform a litter transfer to place the patient wearing their inner garments (for example, BDU/ACU) and protective mask on a clean litter.

(4) Patient lifts are performed with the litters on deck, not on litter stands. To do this, the patient's outer protective garments are removed and are lying under the patient on the litter. The patient is log rolled to the side. A clean litter is placed on top of the cut off clothing along the patient's back. The patient is then rolled back on to the clean litter. The litter containing the contaminated clothing is taken to the first compartment to be washed and the contaminated garments are bagged on the deck.

(5) Procedures on the deck require four personnel with at least one nurse or medical corpsman per lane. Up to three lanes can be established for the concurrent processing of patients. Personnel are at MOPP Level 4 with decontamination TAP aprons and a voice amplifier on the mask.

(6) Decontamination aprons are worn so that team members can decontaminate themselves before lifting the patient and also to keep the knees of their protective overgarment dry if they must kneel on the deck. Decontaminate TAP aprons and gloves between each patient.

---

Note: All transfer techniques should be practiced by the decontamination team using personnel or weighted mannequins. These transfer techniques will need to be modified based on the injuries of the patient.

---

#### **CAUTION**

Bandages may have been applied to control severe bleeding and are treated like tourniquets. Only medical personnel remove bandages, tourniquets, and splints. Cut around bandages during clothing removal. Bandages should remain on the patient until the skin decontamination station.

(7) Decontamination team members on the flight deck gather contaminated equipment, clothing, and other items placing them in a contaminated trash bag for removal. They decontaminate their rubber gloves in preparation for the next patient.

(8) Once all patients have been taken into the passageway, all equipment and decontamination supplies are placed inside the first set of doors of passageway 03-39-4. The handles of the doors leading into the decontamination station are also decontaminated. Outer garments from the patients are gathered up, along with discarded bandages, and are placed in designated contaminated trash bags. These bags are secured temporarily in the passageway so that helicopter operations can resume. Cutting teams decontaminate their own gloves, aprons, hoods, and masks.

(9) Decontamination team members must take frequent water breaks.

### **33. Procedures to be Performed in First Compartment**

a. Remove Inner Garments to the Skin and Decontaminate the Skin. This requires four personnel with at least one nurse per compartment. Up to three lanes may be established per compartment for the simultaneous processing of patients. Personnel are at MOPP Level 4 with decontamination TAP aprons and a voice amplifier on the mask.

(1) Prepare for Decontamination Operations.

(a) All cutters have decontaminated their gloves, scissors, and stainless steel work tables (work stands) with decontamination solution. All clothing from the previous patient has been bagged for return to the entry passageway.

(b) Flight deck team leader passes patient's treatment status and injuries to the leader of team in first compartment.

(c) The patient remains on the *clean* decontaminable litter as it is placed on the stainless steel table in the first compartment. Doors to the compartment should remain closed.

(2) Remove Patient's Uniform.

(a) Decontamination personnel dip their gloves in the 5 percent hypochlorite solution.

(b) Remove the patient's personal effects from his uniform pockets. Place these in the plastic bag. Reseal the bag. If the articles are not contaminated, return them to the patient. If the articles are contaminated, place them in the contaminated holding area until they can be decontaminated and then return them to the patient.

(c) Remove uniforms and undergarments following the same procedures outlined in paragraph 13 above.

(d) Removal of IV bags and tubing is at the discretion of the medical director of decontamination. The IV lines should be protected during patient litter transfer.

(e) Old tourniquets, bandages, and splints are bagged with contaminated clothing.

b. Cleaning Wounds. Follow procedures in paragraph 6 of this chapter to clean wounds, and change splints and tourniquets.

c. Decontaminate the Skin, Hair and Litter. Sponge soap and water over the patient's body including his hair, as the hair readily absorbs agent if it is exposed to agent vapor. Exercise care not to get decontaminant in the patient's eyes (if they are not wearing their mask). Log roll the patient to one side to apply the decontaminant to his back. Apply the decontaminant thoroughly to the litter while the patient is rolled to the side. Rinse the patient and litter completely with the spray device.

d. Transfer the Patient to the Second Monitoring Compartment.

(1) The decontamination team members check to see that the second compartment, the monitoring compartment, is ready (outer door closed and compartment not occupied by another patient) before opening the door and taking the patient into next compartment for monitoring.

**CAUTION**

A period of 10 minutes is required for a complete purge of airborne contaminants in the compartment; that is, the door into the monitoring compartment cannot be opened until 10 minutes after the door into the skin decontamination compartment was last opened.

(2) Discarded clothing is bagged and is passed back to the passageway only after the patient has been taken to the next compartment and the door has been closed.

(3) Once the door is opened to the monitoring compartment move the patients on their litters to that compartment.

(4) Decontamination team members wipe down their TAP aprons starting from the top and working down using the 0.5 hypochlorite solution or soap and water. They also wash their gloves with 5 percent hypochlorite solution and ensure all cutting tools are placed in the bucket containing 5 percent hypochlorite solution. The steel table is also washed off with the 5 percent hypochlorite solution before the next patient enters.

### 34. Procedures to be Performed in Second (Monitoring) Compartment

a. This requires two personnel per compartment. Personnel are in mask only (voice amplifier on mask), with gloves (7-mil thickness) and apron.

b. Prepare for Monitoring Operations.

(1) Monitoring for chemical contamination will be performed with the ICAM and for radiological contamination with the AN/PDR 77 RADIAC meter. There are currently 4 each per ship. There is no real-time monitoring capability for BW agents.

(2) For CW agent monitoring, the ICAM should be turned on as soon as the team is alerted that a chemically contaminated patient is to be received. Pressing the on/off switch on its left side and waiting for the display to clear in the H mode turns it on. It should be warmed up, preferably for 30 minutes, using its alternating current adapter. It must be warmed up and cleared before it can be used effectively for monitoring. Information on using the ICAM is found in TM 3-6665-331-10/TO 11H2-20-1.

(3) The ICAM must be turned on or off in the H mode only. If it is not in the H mode when you turn it on, turn it off momentarily, change modes and turn it back on. The ICAM's computer must be in the H mode to perform its automatic initialization routine.

(4) Perform confidence checks on both modes. Also perform confidence checks after monitoring each patient.

- Apply the confidence tester to the ICAM/CAM inlet for only 1 second, then pull it away. Longer than this will require much longer for the ICAM display to clear.
- If the ICAM is working properly, the confidence check should cause a response of at least 3 bars, preferably 5 bars. If not, try the confidence test again. If a minimum of a 3-bar response is not obtained, the ICAM should be replaced (or be run for an extended period to improve its response).

(5) Before the patient arrives, unplug the ICAM so that it operates on battery power and the length of the alternating current power cord does not restrict its movement. Unplugging causes a momentary interruption in power and requires about 1 minute to initialize the ICAM again. The ICAM can be operated in the battery power mode either with the D-cell adapter (which allows for alternating current operations) or with the special lithium battery (NSN 6135-01-362-1368). Monitoring should be initiated with fresh batteries to prevent interruptions.

c. Monitor the Patient and his Personal Articles.

(1) Monitor with the ICAM in each mode if the agent is unknown. If two ICAMs are available, set one on the H mode and one on the G mode and monitor with both concurrently. If there is certainty of the type of agent the patient was exposed to (for example, based upon M8 detector paper readings prior to patients' arrival onboard the ship or the patient's medical signs and symptoms) monitor with both ICAMs on the same mode. Monitor the—

- Person.
- Litter, particularly the handles.
- Bag of personal effects.
- Field medical card.
- Identification tags.
- Intravenous bag and tubing.

(2) Keep the ICAM inlet about one half inch from the skin. The greater the distance, the less likely it is to respond to the contamination.

(3) Move the ICAM slowly over the surface; about 1 foot every 2 seconds and follow a pattern that ensures the person is monitored thoroughly.

(4) As soon as any bar readings appear, pull the ICAM away and/or put on cap.

(5) Check first the areas that would most likely be contaminated: near wounds where the garment was broken and at the neck, ankles, and waist. Also monitor the areas that might adsorb agent vapor, such as the hair.

(6) If contamination is found, stop monitoring and note the general location. Use the decontaminant to spot decontaminate where the ICAM indicates there is contamination.

(7) Replace the black cap on the ICAM nozzle between patients, even though the display may be showing no bars.

(8) Before switching channels (or turning off the ICAM), always clear it by putting on the inlet cover and waiting for a zero bar reading.

---

Note: It is acceptable to switch from G to H with one bar showing, but to switch from H to G, the display must first show no bars.

---

(9) If the letters "BL" appear on the display, it means the battery is low; replace the D-cell batteries if this occurs. Three dots mean it is momentarily confused by what it is sensing.

d. Remove the Mask.

(1) Once monitoring is complete and there is no contamination present, remove the patient's mask. Place the mask in a small trash bag and close it by knotting the neck. This mask does not proceed into the ship's MTF with the patient.

(2) After removing the mask, clean the face. Pass the bagged mask back to the first compartment when the door is opened for the next patient to enter.

e. Transport the Patient from the Decontamination Station. Cover the patient with a clean sheet and transport him to the clean staging area in the elevator passageway.

#### **CAUTION**

A period of 10 minutes is required for a complete purge of airborne contaminants in the compartment; that is, the door into the clean staging area cannot be opened until 10 minutes after the door from the skin decontamination compartment was last opened.

### **35. Procedures for Decontaminating the Facility and the Decontamination Team**

a. Once all patients have been processed through the decontamination station, the CBRD coordinator will direct the team members in decontaminating themselves (technical decontamination), the decontamination station, and the flight deck.

b. Team members from the flight deck will begin decontaminating first, as their portion of the process ends first. They apply 5 percent hypochlorite solution to areas of the flight deck upon which litters were placed during the processing. They place all discarded material in bags, seal them by double knotting the necks of the bags, and ensure all debris are removed from the flight deck. They then decontaminate scissors, long-handle seat belt cutting device, rescue knives, and aprons and place these reusable items in the entry passageway.



c. As soon as the last patient has been transported out of the skin decontamination compartment, the team members in that compartment bag all discarded items, then decontaminate (with 5 percent hypochlorite solution) the patient table, cutting devices, bulkheads, and deck. These items and the room are then to be rinsed with water.

d. Team members from the flight deck then decontaminate their gloves and overboots and proceed into the entry passageway to remove overgarments. The team members will remove their overgarments in the passageway as follows:

(1) Using the buddy-method, each member will cut the back of the overgarment smock with a long-handle seat belt cutting device, or scissors. The overgarment jacket is cut upward from the waist through the hood or in the reverse direction. The overgarment is removed from the front. The overgarment arms are turned inside out as the smock is removed, roll the cut smock inside out, and place it in a contaminated trash bag.

(2) Each member then removes the overgarment trousers by cutting each leg from the back, starting at the ankle, and proceeding through the waist. The cut trousers are also to be sealed into contaminated trash bags.

(3) The team members of the first compartment decontaminate the exposed areas of their masks, aprons, overboots, and gloves in order. The team members then remove their TAP aprons and hang them up. The team members empty buckets of decontamination solution. Then remove their overgarments as described above. The team members remove overboots last and leave them in the room to aerate.

(4) While still wearing mask and gloves, the team members place the bagged overgarments near the entrance to the compartment and proceed into the monitoring compartment to undergo an ICAM check.

(5) Once the ICAM check shows they are clean, the team members remove their masks, then their gloves, leaving both in the compartment to aerate, and proceed into the clean staging area.

---

Note: Scrubs may be pre-positioned here for team members to change into upon completion of the decontamination process.

---

(6) Once the team members from the skin decontamination station have moved into the monitoring compartment, the flight deck team members move from the entry passageway to the skin decontamination compartment wearing their masks, gloves, and overboots. The team members first place the bagged garments left in the compartment into the entry passageway and shut the door.

(7) The team members next remove their overboots and leave them in the compartment to aerate. Wearing mask and gloves they precede into the monitoring compartment once the preceding team members have vacated it.

(8) Once monitoring, if chemical or radiological agent is suspected, has established that each team member to be cleaned, he removes the mask, then gloves, and leaves both items on the patient table to aerate and exits into the clean staging area.

(9) Once the detector operators have monitored all personnel and cleared them to exit the decontamination station, they will move out, back through the decontamination station, making checks to ensure the areas and equipment have been decontaminated. On the flight deck, they will monitor areas of the deck that have been decontaminated and the weapons that have been taken from the patients.

---

Note: When monitoring with ICAM on the flight deck, strong winds can affect the ICAM's ability to detect. The ICAM nozzle must be held the proper distance from the surface, about one-half inch, and must be swept over the surface at a slow rate (about one-half foot per second) to monitor most effectively. The ICAM/CAM is also susceptible to false positive readings in the presence of Aqueous Film Forming Foam and Jet Propulsion-5 fuel.

---

(10) Once all monitoring outside the decontamination station is completed, ICAM operators will unmask and secure the ICAMs.

e. Disposal of Contaminated Garments. Contaminated garments, bandages, splints, and other items removed from patients in the decontamination process are placed in double contaminated trash bags and sealed by double knotting the necks of the bags. Once the decontamination operations are completed and the flight deck has been cleared, these bags are taken aft, remaining outside the skin of the ship, to the biological materials incinerator.

### **36. Moving an Ambulatory Patient Through a Patient Decontamination Station on a Water Vessel**

a. The ambulatory patient is escorted and assisted through the process by a member of the decontamination team. As with litter patient decontamination, contaminated ambulatory patients are initially processed in the open air of the flight deck where they are triaged and outer clothing is removed; they are then brought to the first compartment where inner clothing is removed and decontamination takes place; after this they are taken to the second compartment where contamination monitoring is performed and the patient is brought inside the ship. There are three pairs of decontamination compartments (three parallel lanes) that allow up to three patients to be processed concurrently with litter patients.

b. The flight deck personnel direct the patient from the helicopter across the yellow line to the on deck triage area. The master-at-arms removes all battle dress items, ordnance, and weapons. Weapons should be secured outside the skin of the ship or within the entry passageway of the decontamination station until they can be monitored to determine that they are free of contamination.

c. The Medical Officer performs triage once ordnance is cleared.

d. On Deck Procedures—Removing the Ambulatory Patient's Protective Ensemble.

(1) Clothing removal procedures are based upon the assumption that patients arrive wearing protective mask, overgarment, gloves, and overboots.

(2) Remove and Secure Personal Articles From the Overgarment Pockets. See paragraph 33 above.

(3) Decontamination team members direct the ambulatory casualties to remove mask hood (if worn) and outer protective ensemble garments for litter patients. Patients can assist one another in this process if they are able. The patients are then directed toward the first compartment. Ambulatory patients can accompany litter patients into the compartment, or move to the compartment in groups.

(4) Decontamination team members on the flight deck gather contaminated equipment, clothing, and other items placing them in a contaminated trash bag. The team members decontaminate their rubber gloves in preparation for the next patient.

(5) Once all patients have been taken into the passageway, all equipment and decontamination supplies are placed inside the first set of doors of the passageway. Handles

of the doors leading into the decontamination station are also decontaminated. Outer garments from the patients are gathered up, along with discarded bandages and are placed in contaminated trash bags. These bags are secured temporarily in the passageway so that helicopter operations can resume. Cutting teams decontaminate their own gloves, aprons, hoods, and masks.

e. Procedures to be Performed in First Compartment.

(1) Remove inner garments to the skin and decontaminate the skin. Decontamination personnel assist ambulatory patients by cutting off undergarments.

(2) Old tourniquets, bandages, and splints are bagged with contaminated clothing.

f. Cleaning Wounds. Follow procedures in paragraph 6 of this chapter to clean wounds, change splints and tourniquets.

g. Decontaminate the skin, hair and litter. Sponge soap and water over the patient's body, including his hair, working from head to toe. The patient should lower their head when washing the hair so that any agent in the hair does not get washed into the eyes and airway. Each individual should shower from 2 to 5 minutes. Decontamination members can help supervise the patients to make sure they wash every area of the body starting with the head and working toward the feet while standing.

h. Procedures to be performed at the Second, Monitoring, Compartment.

(1) The decontamination team members check to see that the second compartment, the monitoring compartment, is ready (outer door closed and compartment not occupied by another patient) before opening door and taking the patient into next compartment for monitoring. More than one ambulatory patient can be brought into the monitoring compartment at a time to speed up the process.

(2) Discarded clothing is bagged. It is passed back to the passageway only after the patient has been taken to the next compartment and the door has been closed.

(3) Once the door is opened to the monitoring compartment move the patients to that compartment.

(4) Decontamination team members wash down their TAP aprons starting from the top and working down. They also wash their gloves with 5 percent hypochlorite (full strength household liquid hypochlorite) solution and ensure all cutting tools are placed in the bucket containing 5 percent hypochlorite solution.

(5) The now nude ambulatory patients will stand with their legs spread at shoulder width and arms held out to the sides. Monitoring for chemical contamination will be performed with the ICAM/CAM, and for radiological contamination, the AN/PDR 77 RADIAC meter, which is currently available on the ship (4 each per ship). There is no real-time monitoring capability for BW agents. The individual's personal articles that are in plastic bags can also be monitored for contamination. If contaminated, the items are decontaminated and returned to the individual at a later date. If uncontaminated they can remain with the ambulatory patient. The patient's identification tags are always worn by the patient.

i. Remove the Mask.

(1) Once monitoring is complete and there is no contamination present, remove the patient's mask. Place the mask in a small trash bag and close it by knotting the neck. This mask does not proceed into the ship's MTF with the patient.

(2) After removing mask, clean the face. Pass the bagged mask back to the first compartment when the door is opened for the next group of patients to enter.

### **37. Procedures for Closing Down the Patient Decontamination Station on Board a Water Vessel**

#### **a. Procedures for Decontaminating the Facility and the Decontamination Team.**

(1) Once all patients have been processed through the decontamination station, the CBR-D coordinator will direct the team members in decontaminating themselves, the decontamination station, and the flight deck.

(2) Team members from the flight deck will begin decontaminating first, as their portion of the process ends first. They apply 5 percent hypochlorite solution to areas of the flight deck upon which litters were placed during the processing. They place all discarded material in bags, seal them by double knotting the necks of the bags, and ensure all debris is removed from the flight deck. They then decontaminate scissors, V-blade rescue knives, and aprons and place these reusable items in the entry passageway.

(3) As soon as the last patient has been transported out of the skin decontamination compartment, the team members in that compartment bag all discarded items, then decontaminate (with 5 percent hypochlorite solution) the patient table, cutting devices, bulkheads, and deck. These items and the room are then rinsed with water.

(4) Team members from the flight deck then decontaminate their gloves and overboots and proceed into the entry passageway to remove overgarments. The team members will remove their overgarments in the passageway as follows:

- Using the buddy-method, each will cut the back of the overgarment smock with a long handled seat belt cutter, or scissors. The overgarment jacket is cut upward from the waist through the hood or in the reverse direction. The overgarment is removed from the front. They turn the arms inside out as the smock is removed, roll the cut smock inside out, and place it in a contaminated trash bag.
- Each then removes the overgarment trousers by cutting each leg from the back, starting at the ankle, and proceeding through the waist. The cut trousers are also sealed into contaminated trash bags.

(5) The team members of the first compartment decontaminate the exposed areas of their masks, aprons, overboots, and gloves in order. The team members then remove their TAP aprons and hang them up. They empty buckets of decontamination solution. They then remove their overgarments as described above. They remove overboots last and leave them in the room to aerate.

(6) While still wearing mask and gloves, they place the bagged overgarments near the entrance to the compartment and proceed into the monitoring compartment to undergo an ICAM check.

(7) Once the ICAM check shows they are clean, the team members remove their masks, then their gloves, leaving both in the compartment to aerate, and proceed into the clean staging area.

---

Note: Scrubs may be pre-positioned here for team members to change into upon completion of the decontamination process.

---

(8) Once the team members from the skin decontamination station have moved into the monitoring compartment, the flight deck team members move from the entry passageway to the skin decontamination compartment wearing their masks, gloves, and overboots. The team members first place the bagged garments left in the compartment into the entry passageway and shut the door.

(9) The team members next remove their overboots and leave them in the compartment to aerate. Wearing mask and gloves the team members precede into the monitoring compartment once the preceding they have vacated it.

(10) Once monitoring, if chemical or radiological agent is suspected, has found each team member to be cleaned, he removes the mask, then gloves, and leaves both items on the patient table to aerate and exits into the clean staging area.

(11) Once the detector operators have monitored all personnel and cleared them to exit the decontamination station, they will move out, back through the decontamination station, making checks to ensure the areas and equipment have been decontaminated. On the flight deck, they will monitor areas of the deck that have been decontaminated and the weapons that have been taken from the patients.

---

Note: When monitoring with ICAM on the flight deck, strong winds can affect the ICAM's ability to detect. The ICAM nozzle must be held the proper distance from the surface, about one-half inch, and must be swept over the surface at a slow rate (about one-half foot per second) to monitor most effectively. The ICAM is also susceptible to false positive readings in the presence of Aqueous Film Forming Foam and JP-5 fuel.

---

(12) Once all monitoring outside the decontamination station is completed, ICAM operators will unmask and secure the ICAMs.

b. Disposal of Contaminated Garments. Contaminated garments, bandages, splints, and other items removed from patients in the decontamination process are placed in double contaminated trash bags and sealed by double knotting the necks of the bags. Once the decontamination operations are completed and the flight deck has been cleared, these bags are taken aft, remaining outside the skin of the ship, to the biological materials incinerator.

### **38. Night Operations**

a. Night operations make patient movement through a PDS more challenging than other operations primarily because of the visual limitations imposed by darkness. Floodlights will typically not be appropriate in a battlefield situation where blackout conditions are imposed to limit tactical vulnerability. Safety and site organization will be critical to successful operations. Blackout conditions will definitely place limits on the following:

- Safe movement of patients and personnel in the area of the drop-off point.
- Safe movement of litter crews through patient triage and treatment areas.
- Ability of medical personnel to visualize patient medical signs which is already made difficult where patients are in protective ensemble.
- Ability of decontamination team to see what they are doing during patient decontamination.

b. Reducing the risk of accident during night operations. To reduce the incidence of accident the following measures are suggested:

- (1) Set up the decontamination site during the day, with the aim of having its lay out simple enough and well understood so that it can be used just as well at night.
- (2) Lanes for movement from the different triage areas are marked with cloth tape, caution tape, or other markings at waist height, so that litter teams will know where to go.
- (3) Routes through the PDS are clear of debris and holes.
- (4) Adequate flashlights, with red lens filters, are available at the arrival point, triage area, treatment areas, decontamination lanes, and hot line.
- (5) Operators have their name and decontamination team member job clearly marked in large letters on tape which is on the front and back of their protective ensemble.
- (6) Operators have voice amplifiers on their protective masks.
- (7) Use chem-lights and, or, construction tape, place at waste level to mark travel routes within the decontamination site.
- (8) Provide personnel at the drop-off point with night vision devices so that they can identify approaching vehicles.
- (9) Be certain of vehicle offload procedures and ensure that patients are moved out of the drop-off point before offload vehicles are allowed to move again.
- (10) Only wheeled vehicles with ground guides are allowed to move in the drop-off point and speed limits of 5 miles per hour (mph) (walking speed) are enforced.
- (11) Mark concertina wire with chem-lights, especially along the hot line, to prevent accidental movement into the wire.
- (12) Rehearse patient movement and processing while there is still sunlight.

### **39. Activities during Night Operations**

#### **a. Entry Control Point.**

- (1) Vehicle marking. Attach the chem-light to the front end of the vehicle, below the level of the hood, to preclude its interference with the driver's night vision.
- (2) The individuals manning the ECP should be equipped with a radio, a pair of binoculars, and night vision goggles for standoff inspection of the approaching evacuation vehicle.
- (3) Once the vehicle halts at the ECP, the ECP personnel should conduct a cautious approach of the vehicle. They should note the MOPP level the evacuation vehicle crew is in and, regardless of MOPP level, question the crew about the numbers and types of casualties they have and what type of agent the patients were exposed to if they know.
- (4) Individuals manning the ECP use M8 or M9 paper to make a rapid and accurate determination of whether or not a liquid chemical agent is present on, or in, a vehicle. Use the ICAM to detect vapors coming from any liquid contamination on, or in, a vehicle. Visually inspect the vehicle at the ECP and test any suspect liquids on the vehicle with M8 paper. Areas likely to have liquid contamination are the vehicle's wheel well areas, tires, and rear portion of the vehicle.
- (5) Information is relayed from the ECP, preferably by radio, to the decontamination OIC or NCOIC. The personnel manning the ECP are in MOPP Level 4. The OIC or NCOIC informs the triage officer and others at the PDS as well as those at the receiving MTF. Knowing

the agent can help care providers better focus their diagnosis and care. It will also help the decontamination team members to know if they need to remain at MOPP Level 4.

(6) Litter teams may be utilized to transfer casualties from the ECP to the arrival point, but this is highly labor intensive and not recommended. The contaminated evacuation vehicle may be routed into the drop-off point on a route that has minimal impact on other vehicle movement into the area.

(7) Ground guides meet vehicles at the ECP who are traveling to the drop-off point. The guides must be equipped with red lens flashlights. Litter bearers, if adequate numbers are available, can serve as ground guides or assistant vehicle commanders can be asked to perform this function. Assistant vehicle commanders can be asked to perform this function. Ground guides will walk no more than five meters in front of the vehicle. Every vehicle must have a ground guide at night. Speed limits of 5 mph (walking pace) must be enforced so that personnel are not run over by vehicles.

b. Triage and Treatment Areas.

(1) Patients are off-loaded from the ambulances, given a pat-down search, and taken to the triage point. The patients are triaged and visibly marked with prepared tags, adhesive tapes. These colors can be used to denote the patients current medical triage category. It is important to remember that triage categories will change as the patient processes through the PDS.

- Immediate – Red
- Delayed – Yellow
- Minimal – Green
- Expectant – Black

(2) The use of these colors can extend into night operations with the use of “chem-lights” in the colors mentioned above, with the exception that the “expectant” patient would be marked with a blue chem-light.

(3) Triage areas will need to be marked with chem-lights, appropriate for the triage category, attached to engineering tape. Medical personnel (medic, corpsman, EMT) must be equipped with red filtered flashlights. Augmentees may need to assist aid men by holding lights for the aid men while they work.

c. Decontamination Lanes.

(1) Site preparation will require time for shuffle pit preparation, dirty dump preparation, and removal of any ground obstacles. If there is time to accomplish any of this labor-intensive work prior to activating a PDS, it will greatly improve PDS operations.

(2) If preparation prior to actual use cannot be done, at the very least a ground reconnaissance must take place prior to site activation. All vehicle movement routes must be marked, points along the route requiring direction indicators identified, and any ground obstacles identified for removal.

(3) Both the litter decon and ambulatory decon areas must be surveyed to ensure ease of movement for litter teams, and decontamination and medical personnel. The ambulatory decon area must be evaluated for direction indicators that might facilitate easy movement of ambulatory patients through the various steps and likewise for any obstacle that might impede foot traffic.

d. Personnel Requirements. Night operations will require additional personnel to fill such jobs as ground guides and individuals to assist medical personnel by holding red lens filter flashlights during triage and emergency procedures in the dirty side triage and EMT areas.

#### **40. Cold Weather Operations**

a. While it is difficult to deploy many CW warfare agents during cold weather, they can be formulated to exist as liquids at cold temperatures presenting primarily a liquid or frozen liquid hazard as opposed to a vapor hazard. As the liquid contaminated individual is moved into a warm environment then liquid agents may begin to present more of an off gassing hazard. Radiological particles present a hazard at any temperature. In cold temperatures biological agents present only a limited hazard, though sporulating agents can still be hazardous if inhaled. Cold temperatures greatly increase the risk of patient cold shock and hypothermia. Patients who are medically compromised because of blood loss, exposure to a chemical agent, or severely ill from a biological or radiological exposure have little energy reserve to maintain their core body temperature and therefore they are more susceptible to developing hypothermia.

b. Where Cold Temperature Challenges Exist. Any environment where the ambient air temperature drops below 65°F (18°C) can present a chill hazard to the medically compromised patient and creates an environment where the use of unheated water for outdoor decontamination is perceived as very uncomfortable by most individuals. A fall or winter climate will present a challenge as will as desert environment that can become very cool once the sun sets. Rainy climates can pose a temperature hazard for patients as well as air conditioned decontamination tents which allow workers longer work cycles, but can create an environment that may be very cool for the medically compromised patient. Medically compromised patients, such as those affected by a significant nerve agent exposure or blood loss, have a greater chance of developing hypothermia, especially in cooler climates.

c. Protecting Decontamination Team Members.

(1) While the risk of heat injury is greatly reduced for the decontamination team members wearing full protective ensemble, heat injury can occur if individuals wear excessive thermal undergarments under their protective ensemble and do not anticipate the heat that their bodies generate once they begin to work.

(2) While protective ensemble will offer some warmth, it is not sufficient to keep an individual warm in colder climates. Wearing a complete uniform under the overgarment will increase the insulation effect. Thin long underwear that can wick sweat away from the body, such as Polypro, can also help when temperatures go below 30°F (-1°C). Keeping active also warms the body.

(3) Decontamination team members should layer clothing under their protective ensemble so that it can be removed if needed. It is best to have a warming tent on the warm side of the hot line where decontamination team members can warm themselves when needed. If a heated warming tent is not available then blankets should be available for staff in the rest area. Just as rest breaks to cool individuals are needed in warm temperatures, rest breaks to warm workers are needed in cold climates.

---

Note: Team members should train at various temperatures to gain a better understanding of the amount of layered under clothing that is appropriate for their work level at the PDS so that they are not overheated while working.

---

(4) Wool glove liners can be worn under butyl rubber gloves in freezing climates. In any cool condition, the cotton liners should be worn under the rubber gloves to help insulate the



hands. Wearing wool or cotton glove liners will reduce the individual's tactile sensation at the finger tips, but the team member's hands must be protected as butyl rubber gloves offer no insulative properties against the cold.

(5) If possible, heated triage and treatment tents or heated buildings should be used. This will reduce both staff and patient exposure to the cold. If contaminated clothing worn by patients has not been removed from them prior to their being brought into these areas, then the areas must be well ventilated so HAZCHEM vapors do not build up inside the enclosed space. Ideally patient clothing should be removed just inside or outside the entrance to these facilities.

(6) In a cold environment, individuals may not feel as thirsty as they would in warm weather, they will fail to drink the amount of water they need, and will then become dehydrated. The recommended daily water intake per individual is from 3 to 6 quarts (3 to 6 canteens).

(7) At freezing temperatures, slips and falls on ice can pose a real hazard to patients and decontamination team members, especially around decontamination tents where soap and water is used. Rock salt, or similar material, should be carried to place on ice patches around decontamination tents.

#### d. Cold Shock and Hypothermia.

(1) Cold shock. This is a patient's sudden physiological response to cold which can rapidly elevate blood pressure and can result in sudden death in susceptible individuals. The risk is greater for those with preexisting heart disease and the aged. Cold shock can be minimized by inquiring about preexisting medical conditions before decontamination, if the situation permits; by encouraging patients to gradually get wet, rather than suddenly stepping into a cold stream of water; or by ensuring that water used for decontamination operations is adequately heated.

(2) Hypothermia. This is a condition of deep body cooling that usually takes longer to develop than one would normally encounter during decontamination operations. Most individuals can tolerate 55°F (13°C) water, but will experience discomfort and shiver severely. This may, however, impact on the individual who is already medically compromised. Shivering becomes the source of self generated heat for people who are exposed to the cold. A cold and shivering individual is generating body heat and this in and of itself is not a sign for alarm. Blood that circulates through the head, arms, hands, legs, and feet cools near the skin surface and will eventually cool the core of the body over a period of time which can lower the core temperature to dangerous levels. The body's vasoconstriction slows heat loss through this process to some degree. Every effort should be made to reduce the amount of time that a patient is exposed to the cold to conserve the patient's body heat, and maintain their core body temperature and their energy. A simple way that medical personnel can assess if a decontaminated patient is experiencing hypothermia is for the medical personnel to place an ungloved hand on the chest or back of the patient. If the skin feels warm, then hypothermia is unlikely. Core temperature is more accurately measured with a hypothermia assessment thermometer which is inserted rectally and can read as low as 70°F (23°C).

- Mild hypothermia. This is characterized by shivering and the person may report that they feel cold. They may have goose bumps on the skin. Individuals may not be able to perform fine motor tasks with their fingers, such as buttoning a button.
- Moderate hypothermia. The individual may be ill tempered and slow moving. They may stumble, slur their speech, shiver intensely, not be able to use their hands effectively, and act inappropriately. Shivering stops when the body core temperature decreases to 86°F (30°C).

- Severe hypothermia. This is a life threatening situation where the core body temperature has reached dangerously low levels. There is a lack of shivering, unresponsiveness, pupil dilation, and cloudy consciousness. The person may be unable to move. If not warmed immediately the individual will progress to respiratory failure, cardiac arrest, and death.
- Refer to Table V-13 for stages and symptoms of hypothermia.

Note: Patient decontamination still remains critical during cold weather operations. Every effort should be made to reduce the amount of time that a patient is exposed to the cold during decontamination to conserve the patient's body heat, to conserve their energy, and to maintain their core body temperature.

**Table V-13. Stages and Symptoms of Hypothermia**

Stage	Core Temp		Status	Symptoms
	°C	°F		
Normal	35.0 to 37.0	95.0 to 98.6	Muscle and mental control and responses to stimuli fully active	Cold sensation; shivering
Mild	32.0 to 35.0	89.6 to 95.0		Physical (fine and gross motor) and mental (simple and complex) impairment
Moderate	28.0 to 32.0	82.4 to 89.6	Muscle and mental control and responses to stimuli reduced or cease to function	86°F (-30°C) shivering stops; loss of consciousness
Severe	< 28.0	< 82.4	Responses absent	Rigidity; vital signs reduced or absent; risk of ventricular fibrillation/cardiac arrest (especially with rough handling)
	< 25.0	< 77.0	Spontaneous ventricular fibrillation; cardiac arrest	

Source: Giesbrecht, GG, *Prehospital Treatment Of Hypothermia* (2001) and *Guidelines for Cold Weather Mass Decontamination During a Terrorist Chemical Agent Incident* (Revision 1, August 2003).

e. Use of Detectors in Cold Weather Operations.

(1) Chemical vapor detectors such as the ACADA and ICAM will not work effectively in cold weather as agents give off few vapors in cold climates. The life of the battery is also significantly reduced, especially at temperatures below freezing.

(2) The RADIAC meters will still be effective in colder climates, but battery strength, as with the chemical vapor detectors, will also be an issue. The AN/PDR 77 and AN/VDR 2 can operate to -40°C and -51°C, respectively.

(3) In freezing climates, chemical vapor detectors can be placed in rest tents that are warm, to measure any vapors in these areas.

f. Patient Decontamination Strategies for Cold Weather Operations.

(1) One method for the selection of appropriate cold weather decontamination is based on ambient temperature. The closer the ambient temperature is to freezing the more patient operations are conducted inside a heated enclosure.

(2) Regardless of the ambient temperature, individuals who have been exposed to a known life-threatening level of chemical contamination should disrobe, undergo decontamination, and be sheltered as soon as possible.

(3) Refer to Table V-14 for decontamination methods based on ambient temperature.

**Table V-14. Decontamination Methods Based on Ambient Temperature**

<b>Temperature</b>	<b>Method</b>	<b>Warm Side Triage and Treat</b>	<b>Clothes Removed</b>	<b>Decon Water Temperature</b>	<b>After Decon Patient Moved To:</b>
65°F (18°C) and above	1	Outside	Outside	Decon outside	Outside clean side triage area
	2	Outside	Outside	Decon outside	Heated clean side triage area
64° to 36°F (17° to 2°C)	3	Outside	Inside	Heated decon enclosure	Heated clean side triage area
35°F (1.6°C) and below					
	4	Inside	Inside	Dry decon (flour, sand, paper towel, M291) for immediate decon	Transport to indoor heated decon area, preferably in a building
Method 1 is the easiest and method 2 is the most complex. Grey areas are where activities are performed inside a heated enclosure.					
Adapted from <i>Guidelines for Cold Weather Mass Decontamination During a Terrorist Chemical Agent Incident</i> (Revision 1, August 2003).					

- Method 1. These are standard patient thorough decontamination operations conducted without special heating tents or water heating apparatus. Decontamination operations that are conducted in the temperature range of 65°F (18°C) and above can be performed in this manner using existing equipment.
- Method 2. Here, standard patient thorough decontamination operations are conducted, but the patient is quickly transferred to a clean side area that is heated. This is typically conducted when temperatures are in the 64° to 50°F (18° to 10°C) range.
- Method 3. Patients are triaged and given lifesaving treatment outside, but are decontaminated in a heated tent with heated water and then moved to a heated enclosure on the clean side of the hot line. This is appropriate when temperatures are in the 50° to 35°F (10° to 2°C) range.
- Method 4. Patient triage, decontamination, and clean side treatment are conducted in a warm area (heated tents, vehicles, or buildings). Dry decontamination is used initially, inside a decontamination tent, until the patient can be transported to a warm facility where the water is heated and the patient remains inside the warm enclosure for treatment. This is appropriate when temperatures are below 35°F (2°C).

g. Steps to Take to Attempt to Reduce the Incidence of Patient Cold Injury and Hypothermia.

(1) Patient protective ensemble should not be removed until the patient appears to be medically stable enough to undergo decontamination.

(2) If temperatures are near freezing, use a dry decontaminant (sand, paper towel, M291, M295) for immediate (gross) decontamination and then move the patient inside a warm tent or room before clothing is removed. Outer protective clothing is removed in a ventilated area immediately outside or near the entrance to the heated room if the garments are heavily contaminated.

(3) If the patient does not need to have their entire body washed, then remove the clothing and decontaminate only those areas not covered by the clothing. Remember that thicker winter clothing, if worn at the time of exposure, will offer some degree of protection against chemical agents as compared with thin summer clothing. Thicker clothing should offer adequate protection against dry particles and spores.

(4) Once the process of clothing removal begins, make the decontamination process as fast as possible so that the patient can be covered again with a blanket.

(5) If available, conduct patient thorough decontamination operations inside a heated building or heated tent. Use warm soapy water for decontamination if possible.

(6) Have ample supplies of blankets on hand to cover the patient as soon as they are decontaminated.

(7) In cold conditions, blankets may have to be available on the warm side of the hot line, in the decontamination area, to cover the patients in between patient lifts if the temperature is cold. These blankets would stay on the warm side of the hot line and could be used for other patients. There is a hazard that contamination could be transferred on the blankets so they should not be reused if they touch the contaminated ground. Ideally, a better solution is to bring the patient into a heated tent and remove clothing, decontaminate, and cover the clean patient as quickly as possible.

(8) If decontamination operations are typically conducted in a location where the ambient temperature is 65°F (18°C) or below, use a PDS system that heats the water used for decontamination and also heats the air inside the decontamination tent. Water may have to be heated to 100°F (38°C) or greater so that it is comfortably warm, but not hot, by the time it reaches the patient.

(9) A PDS with plumbed tentage and sprayers that is operating in a climate where the temperatures are near or below freezing must have heaters for the fresh and wastewater storage bladders so that these do not freeze. Water transport lines should also be covered and insulated to prevent freezing along these narrow areas. Power generators should remain on or kept warm so that they do not freeze.

## Chapter VI

# VETERINARY SERVICE SUPPORT AND FOOD AND WATER SAFETY

### 1. General

Food may become contaminated from enemy employment of CBRN weapons/agents or from terroristic contamination of food procurement facilities and food supplies. The CBRN agents may be introduced during production or in the storage area of the procurement facility; while the product is in transit; at the military storage facility; or at the unit food service facility. Regardless of where the agent is used, the effect is the same; personnel will become ill or die if they consume the contaminated food.

### 2. Veterinary Service Support

a. The US Army Veterinary Corps under the direction of Secretary of the Army and supervision of The Surgeon General of the Army is the DOD Executive Agent for veterinary service for all DOD Components (US Army, US Marine Corps, US Navy, and US Air Force). Refer to DODD 6400.4 for more information.

b. The Secretary of the Air Force provides the food inspection program at Air Force bases and may develop locally approved lists of food suppliers from which food products are procured only for individual Air Force installations.

---

Note: The heads of the other DOD components will coordinate with the DOD Executive Agent on related matters under their areas of cognizance.

---

c. The US Army Veterinary Corps' mission is to execute veterinary service support essential for HSS and sustain a healthy and medically protected force; train, equip, and deploy the veterinary force; and promote the health of the military community. In some instances veterinary service support is provided to allies/coalition partners and/or host nation agencies. The US agencies that may be provided this support include—

- Department of Agriculture.
- Department of Commerce.
- Department of Transportation.
- Department of Homeland Security (DHS) (Transportation Security Agency, USCG, US Customs, US Border Patrol, and US Secret Service), and the Department of Justice (Drug Enforcement Agency).
- Department of State.
- Federal Bureau of Investigation (FBI).
- Central Intelligence Agency.

d. The veterinary services and support mission areas are—

- Food safety, food security and quality assurance.
- Veterinary medical care.
- Veterinary preventive medicine (combines aspects of both food safety and defense and veterinary medical care).

### 3. Food Safety and Security and Quality Assurance

a. To ensure food safety, veterinary personnel inspect and monitor food from its procurement until it is issued to the consumer. Throughout the AO, all Services logistics and food service personnel must take precautions to protect subsistence from contamination.

b. Some of the functions of veterinary personnel—

(1) Perform surveillance inspections of operational rations.

(2) Perform sanitation audits of commercial facilities that produce such items as dairy products, seafood (fish and other waterfoods), red meats, poultry, eggs, pork, baked goods, fresh fruits and vegetables, bottled water, and block or packaged ice. See AR 40–657/NAVSUP 4355.4H/MCO P10110.31H and the most current version of Military Standard (MIL-STD) 3006A for definitive information on sanitation audits of commercial food establishments.

(3) Perform surveillance inspections of all Service-owned subsistence received, stored, issued, sold, or shipped from/to military installations (including those items received from depots and supply points). See AR 40-656/NAVSUPINST 4355.10A/MCO 10110.48 for definitive information on veterinary surveillance inspections.

(4) Conduct basic food screening and microbiological laboratory procedures to ensure adherence to food safety standards and to identify potential foodborne pathogens.

(5) Advise theater logistics units (sustainment brigade; area support medical company; multifunctional medical battalion; brigade support battalion; ration breakdown point; and dining facilities [DFACs]) on storing subsistence to minimize the threat of CBRN contamination.

(6) Inspect, monitor, and submit laboratory samples of subsistence or food-producing animals that are contaminated or suspected of being contaminated by CBRN agents.

(7) Provide units with guidance and instructions for the proper handling or decontamination of subsistence.

(8) Protect the financial interests of the government as it affects the use and disposition of safe, government-owned subsistence.

(9) Participate in humanitarian and civic assistance or disaster relief actions as directed.

(10) Provide food surveillance inspections of DFACs for security and storage of food products.

c. The security of food from the point of origin until it is consumed by stateside or deployed US forces must be maintained. Security and proper storage are key factors in preventing deliberate contamination of food and water. To mitigate the risk for foodborne illnesses, all units must use the basic principles of risk management. See FM 5-19 or Marine Corps Order 3500.27B for definitive information on risk management. The basic principles for risk assessment should be the guide for developing techniques and procedures for ensuring food defense. See USACHPPM TG 188 for definitive information.

d. All planners must integrate risk management for food and water into the mission planning, preparation, and execution of all operations. They must answer the questions about what needs to be done to ensure our food and water is secure, protected, and safe for consumption. The medical planner should identify all food defense and safety issues as they develop the medical annexes to operations orders. The veterinary staff officer provides input on all food safety and food defense issues to the medical planner for inclusion in the medical

annexes of the HSS plan. See Appendix B for more information on HSS annex. Commanders must be aware that food defense is part of the overall HSS effort.

e. Make risk decisions at the appropriate levels in the chain of command. The responsibility for food defense and safety must be assigned and or identified by TSOPs. Commanders are ultimately responsible for food safety and security.

f. Do not accept any unnecessary risk when it comes to the safety of food and water.

#### **4. Veterinary Medical Care**

a. Provide comprehensive veterinary medical care for all MWDs in the AO.

b. Provide limited veterinary care to other DOD-owned animals and other government-owned animals (GOAs) when time and resources permit and to indigenous animals, as directed.

c. Veterinary personnel are concerned with the protection of GOAs and animals procured for consumption. Animals must be protected from CBRN contamination, whenever possible. If feasible, animals should be moved into enclosures to protect them as much as possible from contamination. Protective equipment is not available for MWDs; however, protection of the animal's feet and body must be considered. When MWDs must cross a contaminated area, improvise foot protection by using butyl rubber material and consider placing MWDs in vehicles to avoid contamination.

d. Since CBPS systems are not available, animal treatment facilities must be established in contamination free areas. Veterinary treatment personnel must remain in MOPP Level 4 when caring for CBRN animal casualties until the animals have been decontaminated. The decontamination and treatment of MWD CBRN casualties is detailed in FM 4-02.18.

e. Veterinary personnel must be practical when considering evacuation requests and handling contaminated animals; the foremost concern is safety of unit and support personnel.

#### **5. Veterinary Preventive Medicine**

a. Veterinary preventive medicine is essential for the identification and control of those diseases that can be transmitted from food, water, or ice and those diseases transmitted from animals to man.

(1) Support prevention and control programs to protect Service members from food- and waterborne diseases.

(2) Evaluate zoonotic disease data collected in the AO and advise PVNTMED elements and higher headquarters on potential hazards to humans.

(3) Establish animal disease prevention and control programs to protect Service members and their families and other DOD and allied personnel from zoonotic diseases.

(4) Assess the presence of animal diseases that may impact the CONUS agriculture system if contaminated equipment or personnel are allowed to redeploy (such as foot-and-mouth disease).

(5) Perform investigations of unexplained animal deaths to include livestock and wildlife and submit samples for identification, if applicable.

b. Animals can serve as sentinels (markers) of CBRN contamination or exposure. Military personnel should report unexpected death or illness of wild or indigenous animals to their supporting veterinary unit, especially if the onset is sudden and large numbers of animals are

affected in a short period of time. This is especially true for BW agents, as most agents cause similar clinical signs in animals and people.

## **6. Veterinary Unit Operations in a CBRN Environment**

a. The primary function of the veterinary unit, while it is in the contaminated area, is concentrated on protection and decontamination of organic personnel, equipment, and MWDs. When possible, the mission and duties of the contaminated unit/personnel may be transferred to other operational veterinary units/personnel by the commander.

b. The availability of noncontaminated subsistence/Class I items in an AO depends upon the amount of planning taken for the protection of subsistence from CBRN warfare. An adequate defense posture for a CW attack will also protect food against BW contamination and radiological fallout.

c. The commanders of veterinary units, develop contingency plans and TSOPs required for the veterinary teams in a CBRN environment (see Appendix B for a sample format for the veterinary support portion of the HSS plan). Plans and TSOPs include procedures for—

- Protecting veterinary personnel in the CBRN environment.
- Training veterinary personnel to function in the CBRN environment.
- Monitoring the security and protection of subsistence in the CBRN environment.
- Maintaining assigned CBRN equipment.
- Inspecting subsistence in the CBRN environment.
- Monitoring the decontamination of CBRN-contaminated subsistence, MWDs, and other GOAs.
- Treating MWDs and other GOAs that become CBRN casualties.
- Reporting intelligence data through command channels.
- Ensuring the security of veterinary equipment, supplies, and personnel.
- Using veterinary personnel to support assigned CBRN missions.

d. Upon receipt of a CBRN warning, veterinary leaders place contingency plans into operation and direct veterinary personnel to assume the appropriate MOPP level. After assumption of the directed MOPP level, veterinary personnel, within limits dictated by the tactical situation, ensure that actions are taken to protect subsistence items, MWDs, and other GOAs.

e. If subsistence items have not been protected according to CBRN protection plans and procedures or if the plans/procedures need modification, a recommendation for corrective action is initiated by veterinary personnel.

f. Following a CBRN attack, all subsistence within the boundaries of the contaminated area is considered contaminated and managed accordingly until testing determines which foods are safe for consumption. As a method of control, subsistence items located in contaminated storage facilities/areas are restricted from issue or use until necessary CBRN testing can be completed. Access to subsistence storage facilities/areas will be restricted based on their level of contamination.

g. In most instances, decontamination of subsistence does not begin until the surrounding area and storage facility are decontaminated. Veterinary teams provide technical guidance on food decontamination procedures to unit decontamination teams.



## **7. Veterinary Support for Subsistence**

a. Veterinary personnel support commanders in developing readiness plans and TSOPs for the protection, decontamination, and use of subsistence items in the CBRN environment. This assistance is either in the form of direct or indirect veterinary support.

(1) Direct veterinary support is provided to commanders by assignment of veterinary personnel at Class I activities. This support consists of technical advice to aid the commander in formulating plans and procedures pertaining to the storage, decontamination, and use of subsistence that may become exposed to a CBRN agent.

(2) Indirect veterinary support is provided to unit commanders by disseminating information and guidance pertaining to CBRN contamination of subsistence.

b. Veterinary personnel inspect subsistence at the user level on an area support basis.

## **8. Veterinary Survey of Storage Facilities and Subsistence**

a. Veterinary Personnel.

(1) Veterinary personnel conduct surveys of CBRN-contaminated subsistence and storage facilities to obtain data for the veterinary assessment of the situation. The designated MOPP level must be adhered to while conducting the surveys.

(2) Veterinary personnel use available CBRN-detection equipment for the survey. The survey is conducted, if possible, in conjunction with CBRN detection or survey teams.

b. Survey of Storage Facility.

(1) A preliminary inspection is made to determine the effectiveness of the storage facility and other protective measures in preventing entrance of a CBRN agent into the facility. An inspection of the structural integrity of the facility is made, checking for such damage as broken windows and holes. The inspector notes any damages and the overall condition of the facility. Other subsistence items will be closely monitored and tested, as needed. Veterinary personnel examine chemical detection tapes for indication of activation by chemical agents. The area surrounding the facility is also examined for the presence of animals, rodents, birds, and insects acting unusual or whose death is unusual or unexplained.

(2) A survey of the storage facility is conducted using CBRN alarms/detectors/monitors to determine the presence of a CBRN agent. The inspection determines if a CBRN agent or residue remains in the facility using the detector paper, tape, and other detection equipment.

(3) Specimens are collected for submission to the supporting laboratory. Recorded symptoms of contaminated Service members or animals, gross pathology, CBRN equipment readings, and other observations are reported. This information, when combined with histopathology and other medical laboratory tests, aids in identifying the nature, level, and type of CBRN agent.

c. Survey of Subsistence Items.

(1) A survey of subsistence items must be conducted to determine the presence of a CBRN agent on or in the item and the extent of damage caused by the contamination. Veterinary personnel select those subsistence items most likely to have been contaminated for testing. The items will be located near entrances, near ventilation inlets, and near aisles.

(2) Packaging materials are tested for the presence of CBRN agents. The presence of unusual liquids or stains is noted. The degree of biological contamination, however, can only be

determined by laboratory analysis. Results of the survey of packaging and packing materials are recorded. If a CBRN agent is present, then this information is included in the survey.

(3) At the completion of the initial survey of the storage facility and subsistence by veterinary personnel, the findings are provided to the commanders. These findings will be as definitive and timely as possible. These survey findings must address the following points—

(a) Survey method and inspection procedures used to obtain data, to include type of detection equipment used. Data obtained from support units, such as medical laboratory/chemical units, should be included, noting the source of the data.

(b) Estimate of the quantity of food contaminated or suspected of being contaminated by the CBRN agent. The quantity of contaminated subsistence is reported by the amount in each of the following categories:

- Individual operational rations; meal, ready-to-eat (MRE).
- A-Rations.
- Unitized group rations (UGR)-heat and serve (H&S).
- Semiperishable ration components.
- Perishable items.
- Medical diet field feeding supplement (not a stand-alone ration; it must be used in combination with the UGR).

(c) The recommendation as to advisability and feasibility of conducting a decontamination operation should include an estimate of the amount (percent) of contaminated subsistence that can be recovered if decontamination is accomplished.

(d) Some subsistence items may require upgraded protective storage in an enclosed facility with controlled temperature and/or relative humidity versus storage in an open area protected by barrier covers. The decontamination process may materially reduce the storage life of the subsistence, thus requiring accelerated movement through the supply system. A determination is made as to type of precautionary markings required on subsistence containers. These precautionary markings aid personnel involved in the storage, issue, receipt, and preparation of the subsistence.

## **9. Testing, Screening, and Collecting Food Samples in the Field**

a. The testing capabilities in veterinary units focus on screening capabilities for the presence of foodborne pathogens, biological threat agents (BTAs), and limited chemical contaminants. If a sample tests positive on the initial screening, more definitive testing can be completed by the area medical laboratory (AML), DOD Veterinary Food Analysis and Diagnostic Laboratory (FADL), or to the US Army Veterinary Laboratory, Europe.

---

Note: For definitive information on how samples are prepared for shipment to the supporting laboratory, see the applicable food laboratory sample guide or refer to Chapter VII of this publication.

---

b. Collecting food samples for laboratory analysis can be accomplished during procurement, receipt, or surveillance of food items. Either veterinary or PVNTMED personnel may collect food samples from food procurement establishments or dining facilities. Food samples will be split so that a portion of the original sample is preserved until the field testing is completed. Perishable samples should be maintained at a temperature of 1° to 4°C during transport.

c. Containers must be approved by the International Air Transportation Association and must contain sufficient material to absorb the entire contents in the event of a leak. The technical escort unit (TEU) should be requested to transport food samples suspected of containing BW or CW agents. For more information on TEUs, refer to FM 3-11.20.

d. Random sampling, however, is not very effective at identifying microbial pathogens in solid food unless the level of contamination is relatively high. If microbial pathogens are present in food, they are usually in very low levels and contamination is found in localized areas rather than uniformly distributed. Thus, screening for pathogens that are present in low levels is usually not an effective means of ensuring the safety of foods. When possible, it is better to test for indicators such as total plate counts, coliforms, or generic E. coli that are likely to be present in higher levels when food is contaminated with pathogens.

e. A documented chain of custody using Department of the Army (DA) Form 4137 (Evidence/Property Custody Document) or OPNAV Form 5580/22 (Evidence/Property Custody Receipt) must accompany all samples suspected of being intentionally contaminated or containing pathogens. These samples will not be split prior to arrival at the first receiving laboratory. This will prevent accidental contamination of the samples and ensure that valid samples arrive at the destination laboratory.

---

Note: DD Form 1911 (Materiel Courier Receipt) has been rescinded however, there is an ongoing initiative to have this form reinstated to be used as one of the chain of custody documents.

---

f. Preventive medicine, hospital and medical laboratory personnel should follow the same basic guidelines how and where to submit samples.

## **10. Subsistence Decontamination**

a. The commander determines if subsistence is to be decontaminated. Veterinary personnel provide technical advice to the commander to assist him in making this decision. The commander concerned determines how subsistence is provided to affected units and what actions, if any, are taken to decontaminate supplies. The commander and his staff coordinate priorities for large-scale decontamination operations.

b. Decontamination removes the contaminant and provides food that is safe for consumption. Food salvage operations require extensive efforts to assess, identify, and evaluate. These efforts are further compounded if food supplies are suspected of being compromised by CBRN contaminants. Decontamination efforts require even more elaborate procedures that impact labor, time, and supplies of operational forces. The use of appropriate decontamination must be emphasized to fit the situation and the mission. That is, decontaminate just enough to sustain operations and keep fighting, rather than to try and control or create a contamination-free environment. Normally, decontamination efforts will be limited to the scope and nature of the packaging and packing materials. In addition, food decontamination, if deemed necessary, would only occur in critical situations where other food supply options are not available. Most decontamination is performed in or very near the AO.

c. There are three levels of decontamination for subsistence. These are individual, unit, and support levels. These levels are dictated by who has control or responsibility for the item.

(1) Individual decontamination. The individual Service member performs this level of decontamination. Individual decontamination of subsistence is performed by each Service member on those subsistence items in his possession at the time of the attack. This is

performed in conjunction with individual/equipment decontamination procedures as soon as possible after a CBRN attack. Individual decontamination of subsistence is limited to operational rations that are in the original containers that do not permit or have not allowed CBRN penetration. The decision to decontaminate subsistence, however, rests with the individual's commander and not with the individual, except when the Service member is separated from his unit. Decontamination procedures are conducted as outlined in the unit TSOP or as modified by the unit commander. At the individual level, decontamination procedures are employed to the extent that the CBRN hazard to the subsistence is adequately reduced or eliminated, thus allowing for continuation of the mission.

(2) Unit decontamination. Unit personnel under the supervision of CBRN-trained personnel organic to the unit perform this level of decontamination. Decontamination procedures for subsistence items in possession of the unit are performed as soon as possible after an CBRN attack and in conjunction with area decontamination procedures. Decontamination is attempted only on subsistence items that are in original, intact containers that do not permit or have not allowed CBRN penetration. Decontamination procedures are conducted by unit personnel in accordance with TSOPs and supervised by unit CBRN-trained personnel. Special decontamination requirements and/or advisability of decontamination efforts are relayed to unit commanders through command or medical channels, as required. The decontamination procedures employed are aimed at adequately reducing or eliminating the CBRN hazard presented by the subsistence.

(3) Support decontamination. Specially trained and specially equipped decontamination units/teams accomplish this level of decontamination. The decision to decontaminate subsistence items at this level rests with the commander responsible for supplies. Support decontamination of subsistence is accomplished at major subsistence storage facilities/areas, such as the GS Class I activities in the theater. At the support level, veterinary personnel advise on technical matters pertaining to the decontamination operations involving subsistence items. Veterinary personnel also monitor the decontamination results and recovery operations. They make recommendations if procedures need modification or correction and ensure that decontaminated subsistence is wholesome and suitable for issue. The support decontamination procedures must eliminate or reduce the CBRN hazard presented by subsistence to as low a level as possible.

d. Disposition of Subsistence. The responsible veterinary officer has final approval for determining whether decontaminated subsistence is wholesome and is fit for human consumption. Subsistence supplies meeting wholesomeness standards should be identified and returned to a protective posture. Subsistence supplies not meeting the standards set for human consumption will be disposed of as directed by the senior veterinary authority.

## **11. Treatment of Military Working Dogs Exposed to a Chemical, Biological, Radiological, and Nuclear Environment**

a. Chemical Agent Protection. The information in this publication and in FM 4-02.285/MCRP 4-11.1A/NTRP 4-02.22/AFTTP (I) 3-2.69 on human casualties of chemical agents generally applies to all animals. Chemical protective doctrine for animals is incomplete, and there is no chemical protective equipment in the current inventory for MWDs. Equipment and doctrine for animals are under development but pending its availability, any degree of protection of the MWD in a CW agent environment will, at best, be extremely difficult. The information given herein applies particularly to the MWD, although these principles can be applied to other animals.

b. Protection of Military Working Dog Rations and Equipment. Bagged MWD food and MWD equipment such as leather leashes and collars and leather or plastic muzzles are subject to contamination and may be difficult to decontaminate or replace in a timely manner. One set of MWD handling equipment and a short-term supply, 1 to 4 weeks, of food should be stored in an impervious and easily decontaminated container for each MWD. Tightly sealed plastic cans (NSN 7240-01-094-4305) may be used or these items may be stored in a nearby chemical protective shelter or protected vehicle.

c. Protective Shelter for the Individual Military Working Dog at the Duty Site. In the absence of MWD protective garments or shelters, it will be difficult to protect a MWD if it cannot be placed in a field expedient protective shelter or in an available collective protection shelter. If chemical attack is likely, the only reliable method of MWD protection is movement from the area. If the MWD must remain on site to perform necessary duty, limited protection may be provided by—

(1) Moving the MWD into an existing structure or vehicle that has been sealed with tape, tarps, or tentage to prevent inflow of contaminated air.

---

Note: In some AOs, the risk of heat injury for an MWD in a sealed vehicle may be higher than the risk of chemical or biological injury during a potential attack.

---

(2) Placing the MWD in its transport kennel and covering the kennel with tarps, tent, or plastic sheets to limit contamination by droplet or liquid agent.

(3) Placing the MWD in a chemical protective shelter with the handler and other personnel when space is available. *This is the preferred method when possible.*

(4) Placing chemical impervious barriers on the MWD's paws if the dog must walk through a contaminated area. It is best that an MWD not be walked through any area with ground contamination but this may be necessary in some circumstances. If this occurs, the following items may provide limited protection if placed over the feet and taped at the carpus or tarsus. None of these items are of a design to be walked on, so the ground contact surface may need to be protected with a more durable material such as—

- Tape or canvas over wrap.
- Mylar (polyethylene terephthalate) specimen bags.
- Outer bag from MRE.
- Extra butyl rubber protective gloves from MOPP garments or JSLIST gloves.

d. Pretreatment of Military Working Dogs to Limit Chemical Agent Absorption and Toxicity. There is no specific preexposure therapy that has been evaluated in MWDs; however, some of the protective measures for military personnel may be implemented.

e. Prophylactic Medication. The effectiveness of the soman nerve agent pretreatment pyridostigmine (SNAPP) tablet is not well-documented in dogs and the effect of this medication on the performance of MWDs has not been evaluated. The DOD MWD Veterinary Service does not recommend the use of SNAPP in MWDs because its effect on MWD detection performance has not been evaluated; however, the use of SNAPP in the MWD may be authorized by the responsible veterinarian and MWD unit commanders.

(1) If SNAPP is used, the handler must evaluate the ability of the MWD to perform in assigned tasks prior to performance of assigned duties. Treated MWDs should be identified as under the influence of the pyridostigmine prior to entry into a contaminated environment and other protective measures should be taken when possible. When used, the recommended SNAPP regimen is ½ tablet (15 milligrams [mg]) every 8 to 12 hours. All precautions regarding

SNAPP utilization as delineated in FM 4-02.285/MCRP 4-11.1A/NTRP 4-02.22/AFTTP (I) 3-2.69 should be followed in MWDs.

(2) If the MWD on SNAPP is unable to perform its mission due to adverse effects of the medication, the dose and frequency should be reduced. If the performance decrement continues on the reduced dose, the MWD must be removed from duty and from the high risk area, or the SNAPP treatments must be discontinued.

(3) Adverse effects of SNAPP may mimic nerve agent toxicity including: salivation, nausea, vomiting, abdominal cramps and pain, diarrhea, miosis and lacrimation, increased respiratory secretions, weakness, muscle twitching, and respiratory distress. If any of these are seen, the dose and frequency of SNAPP must be decreased or the SNAPP must be discontinued.

(4) Skin Exposure Reduction Paste Against Chemical Warfare Agents. The use of SERPACWA on MWDs may provide protection against cutaneous absorption of chemical agents. When applied to the nonhaired portions of the MWD's abdomen, groin, and axillae (armpits), SERPACWA may provide some protection for up to 4 hours. The use of SERPACWA will also ease decontamination when using M291 SDK, RSDL, or soap and water.

## **12. Protection Against Nerve Agents**

a. Nerve agents dispersed either by aerosol, vapor, or spray can be absorbed through a dog's respiratory tract, eyes, mouth, gastrointestinal tract, and skin. Currently, there is no means of protecting a MWD's respiratory tract. Respiratory absorption may occur after dispersal of aerosol, vapor or liquid agents and is of greatest concern because of the speed of absorption and toxicity. Absorption of nerve agent through the mouth may occur simultaneously with respiratory exposure. However, oral and gastrointestinal absorption is of greater concern when a dog ingests nerve agent by eating contaminated food, drinking contaminated water, or licking its own fur that is contaminated with a nerve agent. Because of the combination of hair covering and lack of sweat glands, the risk of nerve agent absorption through the skin is of less concern in dogs than in people; however, the risk is still significant. Absorption through the skin via the MWD's paws is of the greatest concern since pads of the MWD's paws have sweat glands, no hair, and will absorb nerve agents.

b. Military working dogs should be protected from direct contamination by liquid and droplets agents. There is no current equipment in the inventory to protect a MWD from inhalation exposure.

c. Liquid nerve agents or vapors of nerve agents can poison food and water. Military working dogs should not be permitted to drink from waterholes or trenches in contaminated areas or to drink surface water that has run off from contaminated areas. Water suspected of being contaminated should be tested by PVNTMED personnel and only water found to be safe should be approved for consumption. Contaminated food or food that is suspected of being contaminated should not be fed to MWDs unless approved by veterinary personnel.

d. Food and water packaged in sealed, airtight cans, bottles, or other impermeable containers can be decontaminated according to information provided above.

## **13. Signs of Nerve Agent Intoxication in Military Working Dogs**

a. All nerve agents generally produce similar effects, although the onset and severity of signs may vary depending upon the route and degree of exposure.

b. Exposure to nerve agent vapors produces local ocular (eye) and respiratory effects before other effects. These signs usually appear within 5 minutes after exposure. The initial ocular effect is pupillary constriction (miosis). Respiratory exposure is manifested by a rapid, panting respiration and an increase in upper respiratory secretions resulting in watery nasal discharge. Increased upper respiratory secretions, with bronchoconstriction which may occur shortly afterward, will cause coughing, rattling sounds in the throat, wheezing, and respiratory distress. More severe exposures may cause eye pain and visual impairment.

c. Systemic absorption of enough nerve agent through the respiratory or gastrointestinal system will increase the severity of local effects and will also cause generalized systemic effects. Respiratory distress becomes marked due to profuse bronchial secretions, bronchoconstriction, and airway obstruction. The distressed animal will gasp and the mucous membranes of the mouth will become blue (cyanotic) as a result of decreased oxygenation. Other effects which may occur are slowing of the heart rate, profuse salivation and frothing, loss of fecal and urinary control, and increased peristalsis and abdominal pain. Muscular effects occur with other systemic effects and the animal will exhibit muscular weakness, twitching muscles, and trembling. As weakness and paralysis of the respiratory muscles progress, breathing becomes increasingly labored, shallow, rapid, and finally intermittent, with the animal quickly becoming oxygen deficient. In severe exposures, the onset and progression of signs are very rapid. The animal may tremble violently, become uncoordinated, collapse, and go into generalized convulsive seizures. Loss of consciousness may ensue with a total loss of reflexes. Convulsions may become intermittent, with the animal showing a rapid panting respiration between convulsive episodes. Marked generalized convulsions are usually followed by complete flaccid paralysis, central respiratory and circulatory depression, asphyxiation, and death.

d. The symptoms of cutaneous exposure to liquid nerve agents are similar to respiratory exposure to nerve agent vapors. One difference is that the initial signs take longer to develop and the transition from mild to severe symptoms may be slower. With fatal cases, the survival period may be hours, whereas in inhalation poisoning most deaths occur in a few minutes. Cutaneous exposure causes local twitching at the site of contamination, increased gastrointestinal activity, salivation, miosis, generalized tremors, prostration, and convulsions. Dyspnea is not a pronounced symptom of early cutaneous poisoning, which differs from the inhalation route. Hypopnea occurs during the prolonged convulsive phase. A lethal factor in cutaneous poisoning is the very rapid rise in body temperature to heatstroke levels caused by the prolonged convulsions.

#### **14. Nerve Agent Decontamination Procedures**

a. Following contamination of the hair coat, skin, or eyes, the animal should be decontaminated as quickly as possible to prevent or reduce any further absorption of the agent.

#### **CAUTION**

All persons who handle animals contaminated with nerve agents must be in MOPP Level 4.

b. Hair and Skin.

(1) Since the hair coat delays penetration of liquid agents to the skin and cutaneous absorption requires several minutes, effective decontamination of the hair and skin may be carried out before any significant absorption has occurred. Decontamination is not a substitute

for treatment. When the animal shows signs of exposure to a nerve agent, specific therapy should be initiated.

(2) The entire animal (except eyes and periocular area) may be decontaminated by using M291 SDK pads, RSDL and/or with soap and water.

(3) Initial MWD decontamination with the M291 SDK or RSDL should be completed as soon as possible after nerve agent exposure. The entire MWD should be wiped down using the M291 pads or RSDL, except for eyes and the area around the eyes, which should be rinsed with water.

---

Note: The MWD handlers should carry several extra M291 SDK or RSDL (replacing the M291 SDK) for decontamination of the MWD and an extra M295 Individual Equipment Decontamination Kit (IEDK) for decontamination of MWD equipment.

---

(4) Definitive decontamination of the MWD should be completed by thoroughly washing the hair coat and the skin with soap (Castile Soap Liquid [NSN 8520-01-519-0776] or available nonmedicated veterinary shampoo) and water. It is important that all body surface areas are saturated with the soap and water and gently scrubbed and washed. After the washing is completed, the hair coat and skin should be rinsed and the soap residue removed from the dog. If soap is not available, rinsing with large amounts of water is the next best method of decontamination. The preferred method of decontaminating the MWD is by first using the M291 SDK pads or RSDL then thoroughly washing and rinsing the MWD to ensure all contaminants are removed.

#### **CAUTION**

Personnel performing the decontamination of the MWD must be careful and prevent any of the SDK pad residue from getting into the MWD's eyes. The decontamination solution could cause injury to the eyes and should not be used on or around the eyes. Ocular contamination should be removed with copious water irrigation of the eyes.

(5) The leash, collar, and muzzle should be removed from the MWD and decontaminated as soon as possible. They may be decontaminated using the M295 IEDK wipe-down mitts or by using a 5 percent hypochlorite solution or with 5 percent sodium carbonate solution (G-agents only). Additional guidance for decontamination of equipment is contained in FM 3-11.5/MCWP 3-37.3/NTTP 3-11.26/AFTTP(I) 3-2.60.

(6) Any amount of liquid nerve agent getting into the eyes of an animal requires prompt action to prevent conjunctival absorption, which can occur very rapidly. The eyes can be decontaminated by irrigation with copious amounts of water until all agents have been removed. Avoid using any components from the M291 SDK or RSDL in the eyes. Petroleum-based eye ointment must not be placed in the eyes prior to completion of decontamination process as it may absorb and concentrate nerve agent and cause additional eye damage and toxicity. After decontamination is complete, the eyes may be treated with appropriate ointments as noted below.



## 15. Treatment of Military Working Dog Casualties of Nerve Agents

a. Emergency Therapy Procedures. Initial first aid provided by the MWD handler depends on the severity of the poisoning and the type of nerve agent antidote kit that is issued to the MWD handler.

(1) For mildly poisoned MWD, administer a total of three (3) ATNAA injections (atropine and 2-pralidoxime chloride [2-PAM Cl] in a single autoinjector) (carried by the MWD handler) into the back of the thigh of the dog. The initial dosage of atropine is 4 mg and the dosage for 2-PAM Cl is 1200 mg. The Mark I is being replaced as supplies are exhausted with the new ATNAA which has the atropine and 2-PAM Cl in a single injector.

(2) For severely-poisoned MWDs, administer three additional injections of atropine with one injection of CANA (diazepam). This is similar to the buddy aid a Service member provides another Service member suffering from severe nerve agent poisoning.

### CAUTION

The MWDs should not need additional 2-PAM Cl injections.

---

Note: Each MWD handler will be issued 2 extra Mark I kits or 3 extra ATNAA plus 5 additional Atropens and 4 CANA for treatment of the MWD.

---

b. Follow Up Handler First Aid for Severe Nerve Agent Poisoning.

(1) Single atropine injections of 2 mg are continued every 10 to 20 minutes until the nerve agent effects have subsided or signs of atropinization appear (see paragraph below). This is equivalent to CLS aid or enhanced first aid for Service members with severe nerve agent poisoning. The MWD must be monitored for heat stress. The atropine dries the mucous membranes thus preventing the MWD from expelling body heat.

(2) The initial dosage of 2-PAM Cl in the dog is 20 mg/kilogram (kg). Three ATNAA injectors should provide sufficient amount of 2-PAM Cl.

### CAUTION

As stated above, the initial dosage of 2-PAM Cl in the dog is 20 mg/kg. Three ATNAA injectors should provide sufficient amount of 2-PAM Cl. This is the treatment protocol that is to be adhered to.

(3) If a MWD is still showing signs of seizure after initial treatment (above) and the first dose of CANA, the handler may give up to 3 additional CANA autoinjections at 5 to 10 minute intervals until the seizures are gone.

(4) Maintain a clear airway by removing respiratory secretions and saliva obstructing the airway. Loosen or remove the muzzle.

### CAUTION

When clearing the MWD airway, the handler and veterinary personnel must use great care to avoid being bitten. Even a minor MWD bite could compromise personnel MOPP status resulting in human nerve agent exposure.

(5) In severe nerve agent exposure, the animal's respiration is markedly depressed and extreme muscular weakness or paralysis is present. In such cases, assisted ventilation is required to effectively resuscitate the animal.

(6) Adequate atropine and 2-PAM CI should bring about an improvement or restoration of spontaneous respiration and also improve blood circulation. However, the effectiveness of 2-PAM CI is lost after a short period of time. The 2-PAM CI varies in its effectiveness against nerve agents. It is least effective against GD nerve agent. If signs of nerve agent poisoning persist or recur, veterinary personnel may need to administer additional 2-PAM CI every 8 to 12 hours for up to 3 days.

(7) Signs of effective atropinization include dry mouth and mucous membranes, increased heart rate, and increased body temperature. Signs of excessive atropinization and atropine toxicity may include: vomiting, thirst, difficulty eating, constipation, difficulty urinating, altered mental status which may be either depression or excessive stimulation, ataxia, seizures, decreased breathing rate, increased heart rate with possible arrhythmias, and abnormal blood pressure (decreased with shock and circulatory collapse or increased). Atropine administered systemically may not overcome local ocular effects so that the absence of pupillary dilation does not necessarily indicate the need for further atropine administration. Canine nerve agent casualties can tolerate much greater doses of atropine than would a normal dog that has not been exposed to a nerve agent. However, repeated doses of atropine will markedly increase its effects, especially in animals that have received only a minimal exposure.

c. Supportive Therapy Procedures.

- (1) Maintain a clear, unobstructed airway. Assisted ventilation may be required.
- (2) Complete decontamination if not already performed.
- (3) Provide supportive treatment, as indicated.

---

Note: As previously stated, atropine is usually sufficient to control CNS signs, but if convulsions persist or occur intermittently and further interfere with respiration, they may be controlled by the administration of CANA intramuscularly.

---

## 16. Protection Against Incapacitating Agents (BZ Type)

a. Absorption and Protection. Significant absorption of BZ, an incapacitating agent, is most likely to occur through the animal's respiratory tract, but effective percutaneous and gastrointestinal absorption can occur. The protective measures for nerve agent poisoning can be applied to incapacitating agents.

b. Signs of Intoxication.

(1) The incapacitating agent BZ is an anticholinergic agent with pharmacological effects similar to those of atropine, although it has a greater effect on the CNS than atropine. The

onset of signs following a moderate respiratory exposure can be expected to occur within 10 to 20 minutes. In general, the greater the dose, the shorter the time for the onset of symptoms.

(2) In the MWD, early effects of moderate exposures to BZ include increased heart rate, pupillary dilation, impaired vision, dry mouth, and a decrease in physical endurance while working. Marked rises in body temperature do not usually occur. The agent's predominant effects are on the CNS, resulting in incoordination, behavioral changes, confusion, and a lack of normal responses to commands. These exposures can be expected to incapacitate animals and make them unfit for service.

(3) There is a large margin of safety between incapacitating and lethal exposures to BZ. Overwhelming exposures, however, can result in prostration and convulsions, with death occurring rapidly. Moderate exposures may cause altered mental status, failure of the MWD to follow commands, and spontaneous aggressive behavior.

c. Treatment.

(1) After a MWD has had a moderate exposure to BZ, effects may persist 24 hours or more. Although the MWD's life is not immediately threatened, therapy can be administered to hasten recovery and return the animal to duty as quickly as possible. However, the MWD should be examined and its work performance evaluated before it is returned to duty.

(2) General therapy for BZ exposure should include decontaminating the hair and the skin with warm soapy water, restricting activity, and keeping drinking water available.

(3) Physostigmine salicylate (0.02 to 0.025 mg/kg) 1 to 1.5 mg per MWD is given by slow IV or intramuscular injections. Repeated doses of physostigmine can be given at intervals of 1 to 2 hours until effective, and then redosed every 2 to 4 hours if signs of BZ exposure persist or recur. Continuous therapy may not be necessary since the effects of the exposure gradually disappear. If continuous administration is required, it should be carried out at reduced dosage levels to avoid an overdose of physostigmine. The signs of physostigmine overdose include pupillary constriction, muscle weakness, twitching, vomiting, diarrhea, respiratory distress, slowed heart rate, and convulsions. If toxicity is noted, further administration of physostigmine should be discontinued and one atropine injector should be given intramuscularly to control severe effects of overdose.

(4) Anesthetics, tranquilizers, and sedatives tend to potentiate the effects of incapacitating agents and are contraindicated in the treatment of MWDs exposed to BZ.

## 17. Protection Against Blister Agents

a. The terms *blister agent* or *vesicant* are misnomers when applied to MWDs since vesiculation (blistering) generally does not occur in dogs or in most other animal species. Despite the lack of blistering, these agents do injure any part of the body they contact. The preventive measures used for nerve agents can also be used for blister agents. If a MWD must transit a contaminated area, it is best if it is placed in the transport kennel and carried. If a MWD must walk through a contaminated area, its paws should be protected to prevent the blister agent from reaching the skin. The effects of specific blister agents and their treatment and decontamination procedures are described in paragraphs below.

b. Distilled HD is a colorless to a dark brown oily liquid with a garlic-like odor. It is used as a delayed-action casualty agent. The persistency depends upon the munitions used and the weather. Although HD is not persistent at high temperatures (100° to 120°F), mustard vapor becomes a major hazard. In addition, with an increase in temperature (90°F) and humidity,

there is a marked decrease in the effective dosage. Also, wet skin absorbs more mustard than dry skin.

(1) Effects.

(a) Liquid mustard or mustard vapors produce delayed effects on the skin and eyes following exposure. The long hair of dogs does not prevent injury to the skin, but it does impede the penetration of liquids and vapors.

(b) Contamination of the skin is followed by a latent period, which varies in length with the degree of exposure. Within 1 hour after exposure, piloerection (erection of the hair) occurs at the site of exposure and may last for an hour or more. Two to three hours after that, redness and edema of the skin develop, increasing in intensity for 24 hours and then subsiding. In mild exposures, edema is followed by exfoliation of the epidermis of the skin. Severe exposures form ulcerated lesions. The lesions heal if secondary infection can be prevented or treated adequately. The skin of the abdomen, axilla, face, and feet are more susceptible to damage from HD and this sensitivity is not directly related to the length of hair protecting the rest of the MWD's body.

(c) The eye is most sensitive to mustard's corrosive effects. Liquid mustard or heavy vapor exposures can be extremely damaging to the entire eye. Mild ocular exposures are followed by conjunctivitis and conjunctival edema, usually appearing within 1 or 2 hours, edema of the eyelids, corneal opacity and inflammation of the cornea, corneal roughening, and pain. More severe exposures can produce more serious lesions, resulting in necrotic conjunctivitis, corneal erosions or deep ulcerations, deep ophthalmic inflammation, and permanent corneal opacification due to scarring. These lesions predispose the eye to secondary bacterial infections.

(d) Mild to severe exposures to mustard vapor damage the respiratory tract. Inhalation of blister agent vapors will produce sloughing and ulceration of the tracheobronchial mucosa first. Profuse inflammatory exudation and edema may cause respiratory distress. More severe exposures produce involvement of the lung tissue, pulmonary edema, and acute pulmonary alveolar emphysema, and may become complicated by secondary purulent bronchopneumonia. The effects of respiratory exposures tend to develop over several days. The signs of respiratory involvement include cough, nasal discharge, respiratory difficulty, fever, and tracheal and pulmonary rales.

(e) Ingestion of contaminated food and water or the licking of contaminated body areas may produce ulceration of the alimentary mucous membranes, resulting in oral ulceration, abdominal pain, vomiting, bloody diarrhea, and prostration.

(f) Systemic absorption of mustard can result from extremely high skin or respiratory exposures or from absorption of the agent from the intestines. It may produce systemic effects involving the CNS, cardiovascular system, and hematopoietic system. The possibility of severe leukopenia and susceptibility to infection also exists. These effects are manifested by excitation, salivation, slowed heart rate, decreased count of white blood cells and platelets, bloody diarrhea, and shock.

(2) Decontamination.

(a) All persons who receive and handle contaminated MWDs must be in MOPP Level 4.

(b) Because of the insidious action of mustard vesicants (where effects are not immediately apparent), decontamination may not be entirely effective. Yet, it is essential to decontaminate MWDs promptly after exposure to prevent more serious injuries and to mitigate

the effects of exposure where possible. Decontamination should be carried out within the first minute or two after contamination with vesicants to prevent injury and before treatment is begun.

**CAUTION**

Decontamination should be accomplished as soon as possible to prevent contamination of handlers and treatment area.

(c) Before redness and edema appear, localized areas of the skin can be decontaminated by using the M291 SDK (or RSDL) as described in FM 4-02.285/MCRP 4-11.1A/NTRP 4-02.22/AFTTP (I) 3-2.69 and washing the MWD with soap and water as described above. Collars, muzzles, and leashes are also decontaminated by using the M295 IEDK wipe-down mitt or by using a 5 percent hypochlorite solution.

(d) The eyes must be decontaminated by copious water irrigation immediately after exposure. The M291 SDK or RSDL should not be used in or around the eyes as it may cause additional ocular injury. Ophthalmic ointments should not be applied to the eye until decontamination is completed as they may absorb mustard agents and prolong corneal exposure thus increasing eye injury.

(3) Treatment. The treatment for either local or systemic effects of mustard blister agents is primarily symptomatic and similar to the treatment described in FM 4-02.285/MCRP 4-11.1A/NTRP 4-02.22/AFTTP (I) 3-2.69 for human casualties. Specific systemic and/or topical antibiotic therapy should be administered when indicated. Supportive therapy may be required to maintain the animal's nutritive and fluid status. With eye injuries, the degree of corneal damage should be determined with fluorescein stain and treated accordingly with antibiotic or antibioticsteroid ointments. The possibility of leukopenia, lung damage, sepsis, or others injuries may also exist.

c. Nitrogen Mustards (HNs) is a colorless liquid when pure with a faint fishy or soapy odor. It is used as a delayed-action casualty agent that has a delay of hours or more before skin-damaging symptoms are felt. The eyes are very susceptible to low concentrations of HN, while a high concentration is required to significantly damage the skin or respiratory tract insofar as single exposure is concerned. Liquid and vapor exposures to HN are less damaging to the skin of MWDs than are equal concentrations of mustard or arsenical blister agents. Exposures of the eye to HN, however, produce more serious lesions than HD exposures do. The respiratory, gastrointestinal, and systemic effects of HN are similar to those effects caused by HD. Decontamination and therapy for HN are similar to those for HD.

d. Arsenical Vesicant Agents.

(1) Arsenical vesicant agents are more damaging as liquids than as vapors. Exposure to liquid arsenical blister agents is immediately painful and the exposed MWD becomes very restless. Lesions produced by these agents are more severe and develop faster than those produced by mustard. Liquid arsenicals on the skin and their inhaled vapors are readily absorbed into the systemic circulation, producing signs of arsenic poisoning manifested by restlessness, vomiting, bloody diarrhea, shock, weakness, anemia, and pulmonary edema.

(2) Decontamination. Procedures for decontamination are the same as those applied for mustard.

(3) Treatment. The treatment protocol provided below is based on the availability of British anti-Lewisite (BAL) ointment and BAL injectable (dimercaprol) that are not currently in the

chemical agent patient treatment set but efforts are underway to procure these items for future sets. If available, the treatment protocols for the ointment and the BAL injectable are provided below.

(a) The treatment of lesions induced by arsenical blister agents is similar to that for other blister agents. To treat localized skin exposures, BAL ointment can be rubbed into the contaminated areas, allowed to remain 5 minutes, and then washed off. Any other protective ointment on the skin must be removed before application of BAL ointment. When BAL ointment is applied, it will penetrate and neutralize arsenical blister agents.

(b) Systemic treatment for arsenical blister agents is indicated when there is extensive skin exposure which has not been decontaminated within 15 minutes, when a very rapid onset of effects follows exposure, or when systemic signs of arsenic poisoning appear. Systemic therapy consists of the administration of BAL injectable (dimercaprol) at 2.5 to 5.0 mg/kg by intramuscular injection. Dosage can be repeated every 4 hours for 2 days and then two times per day for the next 10 days or until recovery is apparent. Supportive therapy should also be administered, as indicated.

## **18. Lung-Damaging Agents (Choking Agents)**

a. Chemical agents that primarily cause pulmonary edema by attacking lung tissue have traditionally been classified as lung-damaging agents (choking agents), or pulmonary edematogenic agents. They include CG, DP, chlorine, and PS. Best known of these agents is CG.

b. The effects of CG in MWDs are similar to its effects in humans. One difference is cyanosis (which is so prominent in human casualties of phosgene) is masked in MWDs. For exposed MWDs, extreme exertion is dangerous, especially when pulmonary edema develops. Military working dogs in shock should be kept comfortably warm and given oxygen, if available. If pneumonia develops, treatment with antibiotics is indicated.

(1) Irritant agents. Under field conditions, the irritant agents bromobenzyl cyanide (CA), chloroacetophenone (CN), and O-chlorobenzylidene malononitrile (CS) have little effect on MWDs. O-chlorobenzylidene malononitrile may cause increased respiration and hyperactivity. Liquid or solid agents in direct contact with the eyes will cause severe irritation; the eyes should, therefore, be flushed with saline or water. For skin decontamination, a 0.25 percent solution of sodium sulfite is more effective than saline or water in dissolving and neutralizing the irritant agent and should be used if available.

(2) Smoke and incendiary agents. Burning particles of white phosphorus (WP) cause deep burns on contact with the skin. The smoke is generally not toxic. Since WP burns spontaneously when exposed to air, oxygen must be excluded to stop the burning. This may be done by submerging the burn or wound in water or by covering it with a water-soaked dressing. At the earliest opportunity, all WP should be removed from the skin as follows: bathe the affected part in a bicarbonate solution (no more than a 0.5 percent solution of sodium bicarbonate) to neutralize phosphoric acid, which then allows removal of visible WP. Remaining fragments will be observed in dark surroundings as luminescent spots. The burn should be debrided promptly if the MWD's condition will permit, to remove bits of phosphorus which might be absorbed later and possibly produce systemic poisoning. An ointment with an oily base should not be applied until it is certain that all phosphorus has been removed. Further treatment should be carried out as for thermal burns. Treatment with ultraviolet light is both palliative and therapeutic. If the eyes are affected, treatment should initially be commenced by irrigation, using water or saline. The lids must be separated and a local anesthetic instilled to aid in the

removal of all imbedded particles. In eyes with severe ulceration, atropine ophthalmic ointment should be instilled once all particles have been removed.

c. Sulfur trioxide-chlorosulfonic acid solution (FS), titanium tetrachloride, and a chemical mixture hexachloroethane (HC). Field concentrations of these agents usually are not harmful to MWDs, but the liquid may cause burns on the skin and in the eyes. After the eyes are irrigated, they are treated the same as for thermal burns.

## **19. Cyanide Compounds (Blood Agents)**

a. Cyanide Compounds. Cyanide compounds (blood agents) affect bodily functions by inactivating the cytochrome oxidase system; this poisoning prevents cell respiration and the normal transfer of oxygen from the blood to body tissues. Hydrogen cyanide and CK are the important agents in this group. Cyanogen agents are highly volatile and, therefore, nonpersistent even at very low temperatures. Exposures at high concentrations cause effects within seconds and death within minutes in unprotected personnel and MWDs. Cyanogen chloride also produces central and peripheral pulmonary effects on the respiratory tract because of its chlorine component.

b. Toxic Effects. These agents produce toxic effects after absorption. Inhalation is the usual route of entry. Artillery shells, mortar rounds, rockets, a sprayer mounted on aircraft, or bombs can disperse these agents.

c. Effects and Treatment.

(1) Hydrogen cyanide causes asphyxiation of the tissues, especially the respiratory center of the CNS. In addition to cyanide effects, CK causes marked local irritant effects on the respiratory system that can lead to pulmonary edema.

(2) Treatment is difficult under field conditions. It should consist of oxygen therapy under positive pressure ventilation and injections of antidote medications.

(3) Initial treatment for MWDs less than 85 pounds is intravenous injection of one sodium nitrite 10 milliliter (ml) (3 percent) ampule containing 300 mg of sodium nitrite, followed by one 50 ml (25 percent) ampule containing 12.5 grams of sodium thiosulfate IV. Military working dogs over 85 pounds should receive an initial dose of two ampules of sodium nitrite, a total of 600 mg, and two ampules of sodium thiosulfate, a total of 25 grams. Sodium nitrite and sodium thiosulfate must be administered slowly through an IV (over 3 to 5 minutes).

(4) If signs of intoxication continue additional medication may be needed. A small amount of venous blood should be examined visually. If the blood is chocolate brown, give an additional injection of sodium thiosulfate at one-half the initial dose quantity. If the venous blood is red, give additional injections of both sodium nitrite and sodium thiosulfate at one-half the initial dose quantity.

---

Note: The initial dosage of sodium nitrite is approximately 4 to 7 mg/pound IV, followed immediately by sodium thiosulfate at approximately 150 to 300 mg/pound. If additional treatment is required, check the blood for methemoglobin (chocolate-brown color). If the blood is not brown, give sodium nitrite and sodium thiosulfate at one-half the initial dose. If the blood is brown, give only sodium thiosulfate at one-half the initial dose, since there should be sufficient methemoglobin present from the original dose of sodium nitrite.

---

## 20. Biological Warfare Agents

a. Disease produced by the offensive use of BW agents against US forces could be lethal and/or disabling. These BW agents could also infect the animal population within the contaminated area; however, most of the diseases that are likely to be used in BW are unlikely to cause illness in MWDs. This is primarily due to varied species susceptibility between dogs and humans for most BW agents. For definitive information on BW agents, see FM 8-284/NTRP 4-02.23/AFMAN (I) 44-156/MCRP 4-11.1C.

b. The veterinary medical response to the threat or use of biological weapons may be different depending on whether veterinary medical measures are employed prior to exposure or whether exposure has already occurred and/or symptoms are present. If provided before exposure, active immunization or prophylaxis with antibiotics may prevent illness in those MWDs that are exposed. Active immunization may be effective against several potential BW agents, in man, but there are no approved canine immunizations for likely BW agents. The best modality for future protection of MWDs against a wide variety of biological threats is the use of prophylactic antibiotics and appropriate decontamination procedures. Of the diseases considered to be likely BW agents, MWDs are likely to be susceptible to only plague (*Yersinia pestis*), tularemia, brucellosis, Q-fever, and anthrax. In all of these diseases the MWD is believed to be less susceptible than man.

c. The DOD MWD Veterinary Service currently recommends that all MWDs deployed to areas with high risk of natural tickborne rickettsial disease be placed on prophylactic doxycycline at 6 mg/kg/day. Doxycycline is generally considered efficacious against each of the diseases of concern and this prophylactic dose may provide additional protection for MWDs against BW agents. Decontamination should be completed with soap and water as previously described. Military working dog equipment should be decontaminated with 5.0 percent hypochlorite solution, or according to FM 3-11.5/MCWP 3-37.3/NTTP 3-11.26/AFTTP(I) 3-2.60.

---

Note: Doxycycline at 6 mg/kg/day is routinely prescribed for MWDs to help prevent natural tickborne rickettsial infections. It may also provide additional protection for MWDs against likely BW agents.

---

## 21. Nuclear and Radiological Weapons

a. A proliferation of CBRN capabilities beyond the lines of the major powers has increased the likelihood of CBRN use in a conflict. The number of Third World countries seeking the technology for nuclear weapons and advanced surface-to-surface missiles has increased. Many Third World or developing nations have current or near-term access to the materiel needed to produce nuclear weapons. With current trends in nuclear proliferation, the nuclear threat now and in the future will be global. The proliferation of nuclear-capable nations in all contingency regions increases the likelihood of US forces being targets of a nuclear attack.

b. If US forces are attacked with nuclear weapons, MWDs will present the same types of medical problems as seen with human patients. These medical problems will include blast, thermal, and radiation injuries and radiation sickness depending on the amount of radiation received. Veterinary care will be based upon the clinical condition of the MWD and its prognosis for recovery. For definitive information on the medical effects of nuclear weapons, diagnosis, treatment, and prognosis, see FM 4-02.283/NTRP 4-02.21/AFMAN 44-161(I)/MCRP 4-11.1B.



## **22. Water Safety and Management**

a. During military operations, the contamination of water, whether intentional or inadvertent, may reach concentrations that will and could produce mass casualty proportions, not only for US and coalition forces, but also, all civilians, plants, and animals in the AO.

b. Water supplies directly affect the combat efficiency, morale, general health, and welfare of Service members in battle. It is required for consumption, sanitation, construction, and decontamination, as well as for vehicle operation and maintenance. The quantity required depends upon the regional climate and the type and scope of operations. The quality necessary depends on the intended use of the supply. Water requirements are significantly greater in sustainment areas, where there is heavy demand for aircraft and vehicle washing, medical treatment, laundry and bath facilities, and construction projects. Patient and equipment decontamination requires large amounts of water.

c. The presence of contamination can be determined only by special methods of analysis. Water samples for identification or verification of biological agent contamination are collected by PVNTMED personnel. The supporting laboratory should provide guidance on sampling procedures and collecting kits (for example, Sep-Pak™) for use in collecting the samples.

d. Treatment of contaminated water requires chemicals and equipment that are only available to logistics water units. Individual Service members or units should not attempt to treat their water. Contaminated water may be decontaminated only when clean sources are not available. These decontamination operations must have the approval of the medical authority (PVNTMED personnel or command surgeon).

## **23. Detection of Contaminated Water**

a. The military standard issue of CBRN detection, protection, and decontamination equipment provides the unit with the ability to detect and protect against a number of CBRN agents. For more information refer to TB MED 577; Navy NAVMED P 5010-9; and Air Force Occupational Safety and Health Standard 48-7.

(1) Detection of nuclear contamination in water is accomplished by using the AN/VDR-2 RADIAC Set/RADIAC meters. However, harmful levels of radiation can exist in drinking water that cannot be detected with the VDR-2. The VDR-2 will detect if water poses an external exposure hazard or if it contains extremely high levels of radiation. It will not however detect levels of contamination above safe drinking water levels. Refer to TM 11-6665-251-10 for more information.

(2) Detection of biological agents in water is accomplished by the use of field biological water test kits and specially designed collection and detection kits. The specialty kits will be provided as needed and will be available to PVNTMED and supporting laboratory personnel.

(3) The Chemical Agent Water Testing Kit, M272, provides a rapid field test to detect chemical agent contamination in water. The test must be conducted before the water is treated with chlorine; the chlorine will affect the accuracy of the test for chemical agents. An updated version of this kit may also detect toxins.

(4) Water Quality Analysis Set—Preventive Medicine (WQAS-PM). The WQAS-PM provides a PVNTMED Team, providing Roles 2 and 3 PVNTMED support, the equipment and capabilities to perform field presumptive analysis of potable water according to TB MED 577 and all associated laboratory support equipment. This set also contains equipment for the bacteriological analysis of potable water for total coliform, presence/absence.

b. When contamination is discovered the following actions are taken:

(1) Mark the water source, using the standard contamination markers, and ensure that personnel do not consume the water until it has been approved by the PVNTMED personnel.

(2) Notify the command surgeon and the commander that the water source is contaminated and unfit for drinking, food preparation, and personal hygiene. The commander establishes safeguards to prevent personnel from using the contaminated water supply.

(3) If the contamination is such that it cannot be removed or avoided, engineering, quartermaster, and PVNTMED personnel will find an alternative source of uncontaminated water.

(4) The primary source for obtaining water is from logistics-operated water production and distribution points. Other sources are considered only when logistics-operated facilities are not available. Alternative sources that may be considered include—

- Ground water source which is least likely to be contaminated.
- Local fixed facility water supplies.
- Movement to another location to obtain an uncontaminated water source, when the tactical situation permits.
- Individual water treatment techniques such as iodine tablets and Chlor-Floc®.

(5) Avoid using contaminated water until it has been treated by logistics water purification units and approved for use by the medical authority.

## **24. Treatment of Contaminated Water**

a. Contaminated water requires additional equipment and supplies to remove the contamination. Logistics water purification and distribution units are equipped to perform these duties.

b. Commanders and their staffs at all levels must be concerned about maintaining water support to allow completion of the unit's mission. To ensure adequate support, commanders and their staffs should address planning for tactical water support in all operation plans and orders.

c. Water is supplied as either a packaged or bulk product. A packaged product is manufactured and procured, stored, transported, and supplied in a container. Water in larger quantities is a bulk commodity.

## **25. Engineer Support**

a. Site Selection. Final selection of a fixed decontamination site is the responsibility of the local commander, usually assisted by the CBRN unit in charge. Direct coordination with an engineer unit must be done so the engineer commander is aware of the requirements for such an area. A fixed decontamination site should be easily accessible but out of contamination range of populated areas. It should be large enough to accommodate planned operations and have drainage and soil characteristics favorable for operations and storage of contaminated materials. Water is an integral part of the decontamination process. Though nonpotable water is used, it must be available and uncontaminated in sufficient quantities or the decontamination operation will cease to function. The site should also be favorable for camouflage and concealment.

b. Site Preparation. The work required to prepare and maintain the site is determined by the CBRN unit responsible for the site, but can be expected to include clearing and grading, drainage analysis, and construction of drainage facilities and hazardous waste holding facilities. Horizontal construction and maintenance of showers, wash racks, and other structures as

required and hardening of the site are engineer tasks. Well drilling, water source improvement, and other support may be required to help the logistics unit supply potable water for the decontamination site.

c. Storage of Contaminants. A large decontamination site generates quantities of contaminated water and materials. The CBRN unit in charge of the site plan is responsible for permanent disposal of these materials. Engineers, however, are involved in temporary storage of these materials, particularly contaminated water. Extreme care must be taken to prevent escape of contaminated water or materials into the surrounding area, especially into potable water sources and sanitation systems.

d. Responsibilities. The Army service component command (ASCC) commander is responsible for the control and distribution of water to US Army forces, to other US Services, and, as required, to allied support elements. The ASCC Deputy Chief of Staff for Logistics has the overall responsibility for developing the water distribution plan for the theater and supervising the ASCC commander's priorities and allocation procedures. Logistical personnel or host nation support, if available, operate and perform organizational maintenance on semipermanent and permanent water purification utilities at fixed installations.

e. Logistics Organizations. The logistics organizations are responsible for the management, control, purification, storage, and distribution of water, including organizational maintenance of water equipment. Initially existing developed and surface sources are used before ground water resources are tapped. The employment of CBRN munitions can contaminate surface water supplies over a wide area. Subsurface water supplies are unlikely to be contaminated at first. Earth and rock layers are effective in diminishing contamination. In an CBRN emergency, it may be necessary to use a subsurface water supply.

f. Environmental Effects on Planning. Environmental conditions determine the location of water sources and how much water is needed for subsistence. For more information on field water supply, see FM 3-34.400. Refer to Tables VI-1, VI-2, VI-3, and VI-4 for environmental factors advantages and disadvantages. Specific guidance regarding environmental factors is found in FM 3-34, FM 90-3, and FM 90-5.

g. Contamination Prevention. Once a well is completed by installing casings, screens, and pumps, it is turned over to logistics water units for use. To prevent contamination, wells must be capped when they are no longer needed. In order to expedite reopening of closed wells, agreements have been made between many host nations to standardize capping and labeling. These procedures are covered by NATO STANAG 2885.

**Table VI-1. Environmental Factors—Temperate Regions**

<i>Temperate Regions</i>	
<i>Advantages</i>	<i>Disadvantages</i>
<p>Abundant resources.</p> <p>Lakes.</p> <p>Streams.</p> <p>Rivers.</p> <p>Existing wells.</p> <p>Local water systems.</p> <p>Sources convenient to locate, develop, and access.</p> <p>Water sources can be purified at small unit level.</p> <p>Drinking water does not require cooling.</p>	<p>Surface sources easily contaminated by CBRN munitions.</p> <p>Natural contamination possible by organics, disease-bearing organisms, and inorganic salt.</p> <p>Environmental pollution from local development such as septic fields may contaminate ground water.</p>

**Table VI-2. Environmental Factors—Tropical Regions**

<i>Tropical Regions</i>	
<i>Advantages</i>	<i>Disadvantages</i>
<p>Water resources available but more scattered.</p> <p>Lakes.</p> <p>Streams.</p> <p>Rivers.</p> <p>Existing wells.</p> <p>Local water systems.</p> <p>Water sources can be purified at small unit level.</p>	<p>Surface sources easily contaminated by CBRN munitions.</p> <p>Dense vegetation may make access difficult.</p> <p>Increase of natural contamination.</p> <p>Presence of waterborne diseases and parasites capable of transmitting disease may make water unsuitable for bathing and laundry use until disinfected.</p> <p>Higher water use needed because of high humidity and heat.</p>

**Table VI-3. Environmental Factors—Frigid Climates**

<i>Frigid Climates</i>	
<i>Advantages</i>	<i>Disadvantages</i>
<p>Water resources may be abundant, but frozen.</p> <p>Lakes.</p> <p>Rivers.</p> <p>Streams.</p> <p>Existing wells.</p>	<p>Increased consumption to prevent dehydration.</p> <p>Water purification, storage, and distribution system must be protected from freezing.</p> <p>Snow and ice are impractical to melt for other than very small units due to excessive fuel needed for melting.</p>

**Table VI-4. Environmental Factors—Arid Regions**

<i>Arid Regions</i>	
<i>Advantages</i>	<i>Disadvantages</i>
None.	Surface fresh water almost nonexistent. Available water sources limited and widely dispersed. Increases water use to prevent heat casualties. May dictate the tactical scenario. Lack of water makes extensive storage and distribution system vital.

**This page intentionally left blank.**

## Chapter VII MEDICAL LABORATORY SUPPORT

### 1. General

a. Medical laboratory services must continue their support role even under CBRN conditions. For the provision of patient care (diagnostic laboratory support), medical laboratory support is located in the field hospital. The facility must be located in a contamination-free area or be inside collective protection. Other designated laboratories within the theater will analyze environmental CBRN samples/specimens (including in-theater field confirmatory identification of BW agents by evaluating specimens from symptomatic patients and animals and environmental samples collected in the AO).

b. At Role 2, medical laboratory support is extremely limited; it consists of clinical laboratory procedures in direct support of MTF and FST activities. Laboratory personnel prepare collected suspect CBRN specimens for submission to the supporting area laboratory for analysis; the specimens are forwarded to supporting medical laboratories and chain of custody is maintained.

c. At Role 3, medical laboratory support in a field hospital is intended for providing clinical laboratory support and is primarily in support of acute surgical cases, blood services, and immediately (STAT) services required for intensive care operations. Microbiology services are also available to include cultures and sensitivity testing. Patients with documented or suspected exposure to CBRN weapons/agents will be medically evaluated, specimens will be collected, packaged, and a chain of custody will be established. For specimens that cannot be handled in the field hospital laboratory, specimens can be forwarded through technical channels to the supporting medical laboratory for analysis. In a mature theater, most of the hospitals will have JBAIDS PCR so field confirmation may be available and that the specimens will be only forwarded through technical channels for definitive analysis.

#### (1) Field laboratories.

(a) Area medical laboratory. The AML is the Army's specialized theater laboratory that provides *field confirmatory* laboratory support. Its mission is, on order, to deploy worldwide in tailored teams to conduct health threat detection, confirmation and medical surveillance for CBRN occupational/environmental health and endemic diseases and consequence management to protect and sustain the health of the force across full spectrum operations. It is organized as follows:

- Headquarters section. This section provides command, control, and communications support for the unit and accomplishes all required administrative functions of the unit.
- Chemical, biological, radiological, and nuclear section. This section conducts analytical chemistry support by providing confirmation level analysis for the identification of CW agents and other chemical threats in air, water, soil or other matrices.
- Endemic disease section. The endemic disease section provides field confirmatory analysis of BW agents in environmental and clinical samples using multiple methodologies; provides diagnostic capability to identify outbreaks of regionally specific endemic diseases; and serves as a resource of information for higher command medical personnel.

- Environmental/occupational health section. This section provides theater-level environmental threat assessments, by conducting air, water, entomological, epidemiological, and radiological surveillance while serving as a resource of information for theater medical personnel. This section also provides radiological monitoring and detection devices, along with laboratory analysis of specific isotopes.

(b) Biological augmentation team (BAT). The BAT is a USAF asset that provides expertise in biological identification and risk analysis. This capability may be utilized to augment existing and future medical UTCs such as EMEDS and Air Force Theater Hospitals (AFTHs). In addition, it may augment the capabilities of the bioenvironmental engineering (BEE) teams, prevention and aerospace medicine (PAM) teams, and theater epidemiology teams (TET).

(c) Forward deployable preventive medicine units (FDPMUs). The FDPMUs (the Navy's environmental theater laboratory) are rapid-response, specialized preventive medicine platforms that identify, evaluate, and assess operational risks of environmental health hazards, including CBRN and toxic industrial threats, and recommend countermeasures to reduce risk for troops. The FDPMU provides specialized PVNTMED support and HSS to operational commanders and joint task forces and can deploy within 96 hours. The FDPMU is a modularized and flexible team to include chemical, microbiological, vector, PVNTMED, environmental health, and logistics components.

(d) Seabasing platforms. Medical departments on aircraft carriers (CVs); aircraft carriers (nuclear) (CVNs); large deck amphibious assault ships (general purpose) (LHA); hospital ships (T-AHs); and command ships are also equipped to provide laboratory testing capability for environmental samples from other ships assigned to a carrier strike group and expeditionary strike group.

(e) Other assets. If these specialized assets are unavailable, clinical specimens may be forwarded to the nearest CONUS reference laboratory including the OCONUS locations at Landstuhl Regional Medical Center, Tripler Medical Center, and 121st General Hospital.

d. At Role 4 (CONUS), designated Role 4 medical laboratories such as USAMRIID, CDC, and NMRC perform analyses to provide definitive identification of suspect BW and CW agents for the President and the Secretary of Defense (SecDef) purposes. The definitive identification of suspect BW/CW agents also aids commanders in the AO in maintaining the health of their command.

## **2. Samples/Specimen Collection and Management of Chemical, Biological, Radiological, and Nuclear Contaminants**

a. The means to initiate a CBRN sample/specimen collection and analysis mission include—

- Routine operating procedures.
- Chemical samples from chemical units.
- Presumptive biological samples from biological detection systems.
- Combat injuries.
- Symptomatic individuals.
- Commander requests for information through C2 channels.



b. The decision makers and initiators of a CBRN sample/specimen collection and analysis mission include Joint and Service-specific commanders, command surgeons, and their supporting medical and CBRN staff elements.

c. Collection of environmental and food samples is conducted by PVNTMED detachment/personnel, chemical operations specialists, damage control personnel, veterinary personnel, PVNTMED officers, public health officers, technical intelligence collection teams, or BEE. Medical personnel in a clinical or hospital setting will collect clinical specimens (for example, serum, blood, and other body fluids) and provide these to the laboratory for analysis. The collection team provides transportation of samples between the collection site and the laboratory analysis site. The laboratory team provides consultation, as needed, regarding the types and sources of samples/specimens to collect. Procedures for collection, labeling, chain of custody, and transport of CBRN samples can be found in FM 3-11.19/MCWP 3-37.4/NTRP 3-11.29/AFTTP(I) 3-2.44. For any CBRN specimen or sample, the supported unit's CBRN staff may specify a TEU to receive and transport the sample. The staff will need to be supplied with the results of the analysis in a timely manner to aid in rapid decisionmaking.

d. Samples are collected and initially packaged by the unit obtaining the sample. The sample is properly labeled, double-bagged, and prepared for evacuation. Ensuring that the chain-of-custody is maintained, the sample is evacuated to a sample transfer point for further evacuation, or possibly to a ship-based medical laboratory for field confirmatory identification. It is critical that the sample be maintained at 1° to 4°C during storage and transport. If a sample transfer point is used, a sample courier receives the sample for transport to an in-theater medical laboratory or ship-based laboratory for field confirmatory identification to support any appropriate treatment decisions. If there is an in-theater AML, the sample can be split for in-theater field confirmatory analysis and evacuation to CONUS for analysis and definitive identification. A portion of the initial sample will ultimately be evacuated to CONUS for definitive identification. If background samples are requested by an in-theater laboratory or ship-based laboratory, for whatever reason, evacuation will be conducted in the same manner ensuring that the chain of custody is maintained throughout the transfer or evacuation process. Sampling and evacuation procedures for BW samples are discussed in detail in FM 3-11.86/MCWP 3-37.1C/NTTP 3-11.31/AFTTP(I) 3-2.52.

- 
- Notes:
1. The term "sample" refers to nonhuman and nonanimal origin. The term "specimen" refers to human and animal origin.
  2. Always consider that chemical agents may have been employed. Check for chemical agents before collecting a biological sample/specimen. Chemical agents can damage or destroy biological agents. Also, chemical agents not identified in the sample/specimen can pose a hazard to the receiving laboratory personnel. Mark all samples that are potentially contaminated with chemical agents as such.
  3. Precautions should be taken to protect the sample/specimen collector from potential BW agents; at a minimum, respiratory protection and rubber gloves must be worn. Additional care must be taken when collecting samples/specimens to prevent cross-contamination. Gloves must be changed or decontaminated between sample/specimen collections.
  4. Samples will not be delivered to the clinical laboratory of an MTF for analysis. They must be delivered to the designated supporting medical laboratory for processing. This will prevent accidentally spreading a biological agent in the MTF.
-

e. The CCDR must ensure it has an executable plan to get the samples to the supporting laboratories. In some cases, dedicated TEU assets are used to escort samples. The priority for dedicated TEU assets will likely go to escorting samples from the theater back to the CONUS-based nationally recognized reference laboratories for definitive analysis and identification.

f. Samples suspected of containing BTA must be collected and transported using accepted chain-of-custody procedures (such as DA Form 4137, OPNAV Form 5580/22, or other form acceptable to law enforcement and federal agencies) to ensure sample-handling integrity for legal purposes. The Judge Advocate General's Office provides guidance and reviews on chain-of-custody procedures. See FM 3-11.86/MCWP 3-37.1C/NTTP 3-11.31/AFTTP(I) 3-2.52 and JBAIDS CONOPS for policy details. Chain-of-custody procedures are used to track all holders of the sample until the sample is destroyed.

---

Note: DD Form 1911 (Materiel Courier Receipt) has been rescinded however; there is an ongoing initiative to have this form reinstated to be used as one of the chain of custody documents.

---

g. A strict chain-of-custody must be maintained for every sample or specimen collected. The chain-of-custody document must accompany the sample or specimen during transport from the point of collection to the receiving medical laboratory to the final disposition of the sample. Each time the sample or specimen is transferred to another individual, the receiving person must sign the document to show that he received the sample or specimen and state what happened to it while in his custody. The document will provide answers to the following questions about the sample or specimen:

- (1) Who collected the sample?
- (2) When it was collected?
- (3) Who has maintained custody of it?
- (4) What has been done with it at each change of custody?

h. The samples or specimens must be appropriately packaged, labeled, and evacuated to the designated medical and/or environmental laboratory for confirmation of a biological attack. The standard chain-of-custody for the evacuation could be as follows:

- Sampling unit.
- Sample courier or other command-designated courier personnel.
- In-theater supporting laboratory.
- Designated CONUS laboratory.

i. For clinical specimens, routine clinical laboratory custody procedures will be employed until the presence of a BTA is suspected based on prior intelligence or initial laboratory testing at which time chain-of-custody procedures will be initiated. Chain-of-custody forms may be initiated prior to determining the presence of a BTA, if desired.

j. Chain-of-custody forms are employed when moving samples to different locations within the same laboratory facility, upon shift changes, and when shipping/transporting samples to another laboratory. Every aliquot of sample *MUST* be accounted for on the chain-of-custody forms until approved for disposal or destruction by the FBI or commander.

k. For additional discussion on the collection and management of suspect BW and CW agent specimens and samples refer to FM 4-02.285; FM 8-284; Allied Medical Publication (AMedP)-8; JBAIDS CONOPS; and FM 3-11.86.

### **3. Handling and Storage of Samples Within the Laboratory**

a. Incoming Sample Disinfection. Although sample containers should have been decontaminated at the time of collection, upon arrival at the laboratory, the outer sample container should be disinfected again (for example, wipe with 5 percent bleach solution) and placed into a protective container (for example, self-sealing plastic bag). This procedure should be performed outside the entrance to the laboratory so as to prevent contamination of the laboratory.

b. Storage. Samples should be stored at temperatures appropriate for the sample type, which is usually in a refrigerator (1° to 4°C) for a short time (up to 1 hour) until it can be processed. After the sample has been split (for example, aliquot taken for analysis), the unused portion of the sample is usually stored in the refrigerator. Because of the hazardous nature of the samples, maintain good physical security on the storage area. Storage containers are to be physically secured to control access so as to maintain chain of custody and assure biosafety.

c. Sample Accessioning. Recording pertinent data about the sample in the laboratory records is critical so that the sample can be tracked and results reported to the appropriate physician, unit, or agency. Using established laboratory standard operating procedures and worksheets, record the type of sample, location from which it was obtained, date and time of collection, sample identifying number, patient identifying information (if appropriate), and other pertinent information, and assign a unique laboratory accession number to each individual sample. In this process, the laboratory must record the sample identification number assigned by the collector, if one exists (see FM 3-11.86). Data may be maintained using paper records or computer databases, if available, and meets the needs of the laboratory. The OPSEC of such records must be maintained.

d. Biological Safety in the Laboratory. According to standard safety practices and Service-specific directives, medical units/facilities will analyze clinical and/or environmental samples according to their established laboratory standard operating procedures and current doctrine and policies. This will minimize the potential for spreading contamination within the laboratory facility and MTF. Standard precautions (that is, gloves, appropriate respiratory protection, and long-sleeved laboratory coat) must be used when handling and analyzing samples. All samples are considered infectious and potential threats until otherwise determined. Samples should be processed in a Class I or II Biological Safety Cabinet while utilizing standard precautions to protect personnel from sample aerosolization and to protect samples from cross-contamination in the laboratory.

e. Due to METT-TC, it may not be feasible for the specimen/sample to be shipped in a timely manner to a laboratory having better containment capabilities. Therefore, under these circumstances, field laboratories should use the best containment and decontamination procedures to process the initial samples. On occasion, CDC and WHO field laboratories have used BSL-2 conditions for these agents. A health risk assessment should be accomplished to evaluate risk, adequacy of control measures, and the need for additional controls such as PAPR. Services will determine procurements of additional environmental engineering controls. If additional respiratory protection is utilized, Services must ensure that proper certification and training are achieved.

f. The handling of samples that may contain Ebola, Marburg, or Variola viruses require additional precautions. Procedures recommended for handling these suspect samples include—

(1) Commanders should make the greatest effort possible to protect the laboratory personnel from these agents. However, assays for these agents are available in field deployed laboratories because the need for laboratory results in a timely manner is so great.

(2) If rapid test results are urgently needed and no laboratory with suitable biological containment facilities is close-by, process the initial sample using the best biological safety methods possible. Once the patient or environmental material is known to contain Ebola, Marburg, or Variola, make all reasonable efforts to send future similar samples to a laboratory with appropriate biological containment facilities. However, if this is not feasible, continue to use the strictest biological safety methods possible to process future samples. Commanders should make all reasonable efforts to limit the further exposure of laboratory personnel to these agents. Use of a PAPR maybe a partial solution.

(3) Dispose of all biohazardous waste using normal biohazard waste transport, tracking, and disposal (incineration) procedures.

#### **4. Confidence Levels of Laboratory Analysis**

a. *Field* presumptive identification for BTA is achieved by the detection of a biological marker through the use of a single test methodology (such as handheld immunological assay, JBAIDS, or Biodetection System alarm). When a CBRN/medical/environmental team sample (soil, water), specimen (body fluids such as blood) collector arrives at the contamination site without a biomarker detection device, the sample/specimen taken from the site must be sent by courier to a laboratory (for example, sample/specimen to the AML or clinical specimen to combat support hospital (CSH) with JBAIDS for FDA-cleared assays only) that has the testing capability. See Figure VII-1.

b. *Field* confirmatory identification for BTA is achieved through the use of devices, materials, or technologies that detect two independent and specific markers with two specific technologies, such as two different nucleic acid and one different protein marker. After the CSH or other field hospital identifies the clinical specimen as a BTA, the specimen then is sent by courier to a specialized laboratory/team with advanced microbiological capabilities and highly skilled medical personnel such as the USA's AML and veterinary units (foodborne pathogens), the USAF's BAT, or the USN's FDP MU when available in the AO. If these specialized laboratories/teams are unavailable, clinical specimens that are presumptive positive for BTA may be forwarded to the nearest reference laboratory including the OCONUS locations at Landstuhl Regional Medical Center, Tripler Medical Center, and 121st General Hospital. Medical departments on CVs; CVNs; LHAs; T-AHs; and command ships are also equipped to provide confirmatory testing capability for environmental samples from other ships assigned to a carrier strike group and expeditionary strike group.

c. The *definitive* identification for BTA is achieved by thorough testing and identification by nationally recognized reference laboratories such as the USAMRIID, the NMRC, or the CDC. These laboratories have highly skilled testing personnel who employ a broad variety of methodologies that are capable of detecting and characterizing numerous biological markers, thus providing the highest levels of accuracy. This highest level of identification is necessary to ensure definitive and unequivocal identification due to the potential international impact, as well as for forensic purposes. The sample/specimen is

transported from the confirmatory facility to the nationally recognized reference laboratory by the TEU or courier.

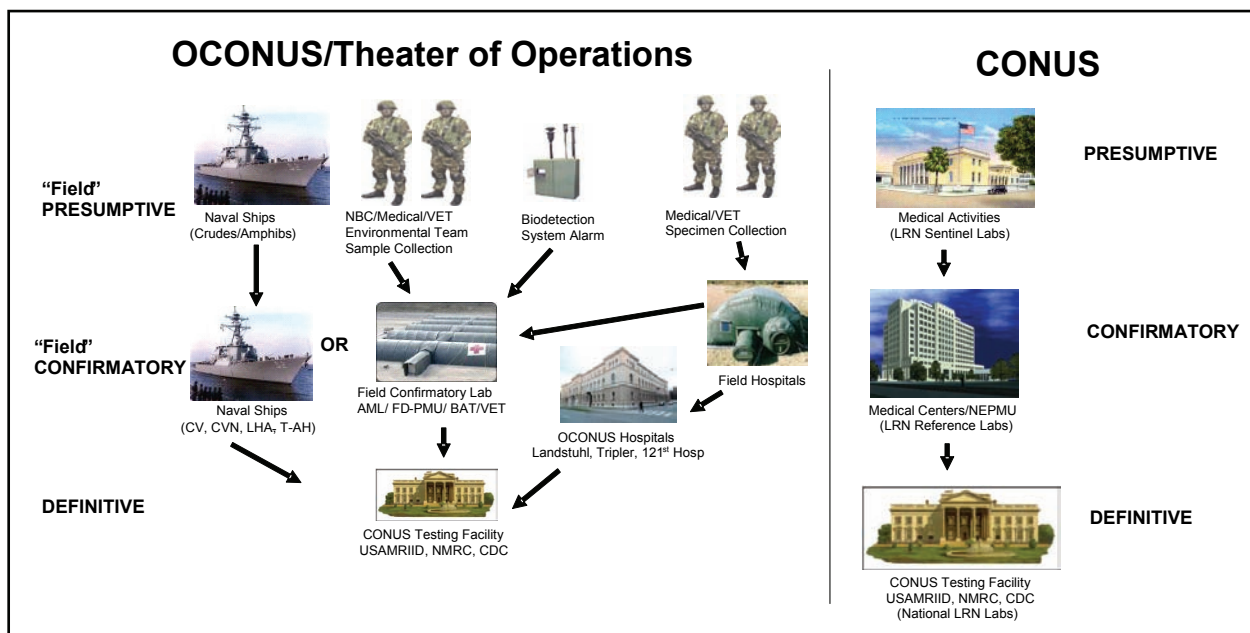

Figure VII-1. Levels of Identification Confidence

d. The terms presumptive, confirmatory, and definitive levels of identification are only reserved for biological sample/specimen. Current policy does not dictate that chemical samples be transported to a definitive level Laboratory Response Network (LRN) recognized laboratory. If a medical laboratory in the theater has the means (such as gas chromatography-mass spectrometry [GC/MS]) to confirm the type of chemical agent used in the attack, the sample need not be transported elsewhere for further testing.

## 5. Joint Biological Agent Identification and Diagnostic System

a. The JBAIDS is a laboratory instrument system that provides medical leaders and commanders with rapid and specific identification of BTA. Through the use of advanced scientific technology PCR, infectious diseases, whether naturally occurring or intentional, can be identified quickly and with high sensitivity and specificity. This rapid identification enables commanders and health care providers to make data-based decisions that govern early warning, intervention, and prevention, including clinical diagnosis of patient disease upon FDA clearance of the assays.

b. The JBAIDS is a reusable, portable, modifiable identification and diagnostic system for biological agents and is capable of simultaneous reliable identification of multiple BTA of operational significance. The JBAIDS will enhance force protection by providing medical personnel and commanders the capability to determine appropriate treatment, effective preventive measures, and prophylaxis in response to the presence of biological agents. The JBAIDS is configured to support reliable, fast, and specific identification of biological agents from a variety of clinical specimens and environmental samples. The intent is to provide timely, accurate identification of specific biological agents to support clinical observations, operational decisionmaking, and data archiving.

c. The JBAIDS is being developed utilizing a block up-grade strategy (3 blocks/increments) to leverage rapidly developing technologies in the identification and diagnostic capabilities arena. The reporting function is compatible with existing C2 using paper reports and manual inputs. In future versions of JBAIDS, reports will be compatible with theater information management systems and data output will be packaged for optimal use by medical staff and by commanders. The system will interface with existing and future C2 systems.

d. Block I (Increment I) uses are adjunct to—

- Clinical diagnosis.
- Medical surveillance.
- Environmental sampling activities (for example, air, water, food, entomology, and veterinary).
- Forensic activities.

e. In clinical settings, JBAIDS will be used according to FDA guidelines. Prior to FDA approval for diagnostic testing, results must be confirmed using established diagnostic methods. The FDA approval process will be ongoing throughout the development and fielding period.

f. The initial JBAIDS is comprised of an analytical instrument with computer and printer, assay reagents for extracting and identifying nucleic acid from various biological agents, and protocols for identification of ten BTA from multiple sample types.

g. The JBAIDS employs a single methodology (nucleic acid amplification) when a sample is positive only by a JBAIDS assays for a single BTA gene target (that is, one biomarker using a single methodology), the result should be as being presumptive. Further operational testing will be required for the JBAIDS to verify that BTA can be detected in the full range of matrices for which the system was designed. However, a JBAIDS positive result may be interpreted as being a confirmatory identification when JBAIDS is the second methodology employed to test a sample that is already a positive result by another methodology. The LRN policy requires testing according to LRN-approved protocols and LRN-presumptive results must be confirmed by a LRN reference laboratory performing additional LRN-approved tests.

(1) Example #1: If a Joint Biological Point Detection System (JBPDs) sample tests positive at the detector site, that result is regarded as a *field* presumptive positive. If the JBAIDS result at the field confirmatory laboratory is also positive, the result may be referred to as being a *confirmed* positive result because of the employment of two methodologies. This sample is then sent to a national reference laboratory for definitive testing. If the JBAIDS result had been negative, then the sample would be called negative and no further testing required unless there were significant reason to doubt the results (for example, other test results, intelligence, or laboratory OIC's belief that system error occurred).

(2) Example #2: If a sample being tested initially at a laboratory employing JBAIDS produces a JBAIDS positive result for a single-gene target only, it would be considered to be a *field* presumptive positive until confirmed by another biomarker or methodology.

(3) Example #3: If a clinical sample being tested using JBAIDS in a CONUS hospital laboratory is positive, the sample must then be handled according to LRN protocols where it may be retested and submitted to a LRN reference laboratory for confirmation.

## 6. Operational Employment

a. Various types of CONUS and OCONUS laboratories in all Services will use JBAIDS for identification of BTA, although in somewhat different ways, depending on the role and other capabilities of the individual laboratory. Precisely which organizations will process which specimen will be determined at the MTF commander, JFC, or at Service-specific major medical commands/levels.

b. The JBAIDS is a laboratory capability employed by certain field-deployed laboratories and fixed-site CONUS and OCONUS sites that provides a force protection tool to enhance the decisionmaking of physicians and commanders of MTFs, installations, and combatant units. Laboratories employing JBAIDS include—

- Field hospitals.
- Fixed site hospitals.
- Theater confirmatory testing facilities.
- Naval ships.
- Definitive testing facilities.

c. The US Army will employ JBAIDS to support the analysis of environmental and clinical samples within the deployed and homeland security settings. Examples of how and where the Army will field the JBAIDS include—

(1) Area medical laboratory provides theater-level confirmatory testing, as well as initial testing.

(2) Medical team, infectious disease augments various types of medical laboratories with presumptive and confirmatory testing.

(3) Preventive medicine detachments screen environmental sample types.

(4) Medical detachment veterinary service screens for foodborne pathogens.

(5) Veterinary Food Analysis and Diagnostic Laboratory tests of subsistence items.

(6) Combat support hospital laboratories are used for the clinical diagnosis of diseases.

(7) Fixed-facility medical treatment facilities provide clinical diagnosis and confirmatory testing.

(8) United States Army Medical Research Institute for Infectious Diseases conduct research and comparison testing.

d. The USN will employ JBAIDS to support the analysis of environmental and clinical samples within the deployed and homeland security settings, depending on the role of the laboratory. These will include both afloat and ashore units such as—

(1) Medical departments on aircraft carriers (CV and CVNs), amphibious ships (multipurpose, LHDs), LHA, and command ships. The role is to provide confirmatory testing capability for environmental samples from these and other ships assigned to either a carrier strike group or an expeditionary strike group.

(2) Hospital ship laboratories are used for clinical diagnosis.

(3) Fleet hospitals/expeditionary medical facilities provide clinical diagnosis and confirmatory testing.

(4) Navy environmental and preventive medical units (NEPMUs) provide confirmatory testing and technical reachback.

(5) Forward deployed preventive medical units provide both initial and confirmatory testing.

(6) United States Navy medical research laboratories conduct technical reachback support to operational users and conduct medical surveillance.

e. The USAF will employ JBAIDS to support the analysis of environmental and clinical specimens within the deployed and homeland defense, depending on the role of the laboratory. The USAF will field the JBAIDS to the Biological Augmentation Team (UTC: FFGL1) and the homeland defense laboratory response team (HLDLRT).

(1) The USAF biological augmentation team (UTC: FFBAT) is a deployable two-person team that utilizes the JBAIDS to test samples to identify biological agents in support of theater joint and Service commander installation protection programs. The FFBAT is deployed as part of the Medical Chemical, Biological, Radiological, Nuclear and High-Yield Explosives Team and supports other deployed medical CBRN or epidemiological teams.

(2) The HLDLRT is a nondeployable two-person team that utilizes the JBAIDS to test samples for biological agent identification at home station and fixed installation locations. This team supports force protection programs and local homeland security responses as required by the installation commander. The HLDLRT works hand-in-hand with the threat agent surveillance team (BEE team).

f. The USMC will employ JBAIDS to support the analysis of environmental and clinical samples within the deployed and homeland security settings, depending on the role of the laboratory. The USMC will field the JBAIDS to surgical companies and the chemical-biological incident response force (CBIRF).

(1) Surgical companies provide clinical diagnosis and confirmatory testing for medical surveillance and force protection.

(2) Chemical Biological Incident Response Force provides confirmatory identification of environmental samples for force protection measures and homeland security responses.

## **7. Nationally Recognized Reference Laboratories (Definitive)**

a. The definitive level of identification is by means of devices, materials, or technologies that detect two or more independent biomarker results using different methodologies. The definitive identification process can be accomplished in several hours to a couple of days, depending on the number of tests required. This level of identification is performed in a reference laboratory with a broader variety of methodologies available and highly skilled testing personnel, thus providing the highest levels of accuracy. Final sample or specimen identification is accomplished at one of the nationally recognized CONUS reference laboratories such as USAMRIID, the NMRC, or the CDC. The preliminary findings by the supporting laboratories provide leadership with valid information that can be used to initiate protective, preventive, and initial casualty care procedures; however, definitive identification is required for legal/retaliatory actions.

b. The US Army Medical Research Institute of Infectious Diseases has played a key role as the DOD's lead laboratory for the medical aspects of biological defense. It is an organization of the US Army Medical Research and Materiel Command (USAMRMC) and is the lead medical research laboratory for the US Biological Defense Research Program.



It is the only laboratory within DOD with the capability to study highly hazardous viruses and highly hazardous infectious agents requiring maximum containment at BSL-4.

c. The CDC is one of the 13 major operating components of the Department of Health and Human Services, which is the principal agency in the US government for protecting the health and safety of all Americans. It is a nationally-recognized reference laboratory providing definitive identification of suspect biological agents. The CDC is available to support installation leadership with a broad-spectrum of laboratory support.

d. The Naval Medical Research Center is a premier research organization that is one of DOD's nationally recognized reference laboratories that can provide definitive identification of biological agents. The Biological Defense Research Directorate (BDRD) of the NMRC serves as a national resource providing testing and analysis for the presence of anthrax and other potential biological hazards. The NMRC conducts basic and applied biomedical research, development, testing, and evaluations in the areas of biological defense, bone marrow, combat casualty care, and infectious diseases. The NMRC invites the contributions of scholars and research specialists into its scientific regimen so as to develop and provide state-of-the art research methodologies to enhance HSS and deployment readiness.

(1) The BDRD has the capability in the rapid and confirmatory detection and identification of BTA in clinical and environmental samples, the directorate explores basic and applied scientific research methodologies for the development of diagnostic assays for the detection of biological and chemical agents during peacetime and wartime. Research personnel have designed, developed, and tested a new prototype immunochromatographic assay device which enables multiple assays to be performed simultaneously. In addition, researchers have been instrumental in the advancement and refinement of confirmatory identification of threat agents utilizing PCR methodologies in tandem with innovative, state-of-the-art biosensor technologies.

(2) The BDRD has become a leader in the field in detection including handheld assays, molecular diagnostics, and confirmatory analysis.

## **8. Other Department of Defense Laboratories**

a. The United States Army Medical Research Institute of Chemical Defense. The USAMRICD can provide laboratory support for the identification of CW agents from human specimens and technical guidance on prevention, protection, and medical management of CW agent injuries.

b. The Armed Forces Radiobiology Research Institute. The AFRRRI can provide technical and laboratory support for nuclear and radiological incidents or events. They can provide identification on the type of radiological hazard that exists and provide recommendations on shielding, hazard levels, and preventive measures. However, their laboratory support capabilities are very limited.

c. The US Army Center for Health Promotion and Preventive Medicine. The USACHPPM can provide technical and laboratory support for TIM incidents.

d. The Army Materiel Command (AMC) Treaty Laboratory. The AMC Treaty Laboratory was established to verify compliance with the Chemical Weapons Convention. It is an ISO 9001 registered quality system that was predeployed to support the FBI during the Olympic Games held in Atlanta.

e. Edgewood Research, Development and Engineering Center (ERDEC). The ERDEC maintains a rapidly deployable mobile environmental monitoring and technical assessment system. This mobile analytical response system provides a state-of-the-art analytical assessment of chemical or biological hazards at incident sites.

f. The Navy Environmental and Preventive Medicine Unit. The NEPMU and the Navy Disease Vector Ecology Control Center are strategically located at installations around the world to meet HSS requirements and to perform confirmation identification of samples/specimens. Forward deployable preventive medicine units have deployable teams with the capability of performing field confirmatory identification of samples/specimens.

g. The Navy and Marine Corps Public Health Center (NMCPHC). The NMCPHC provides functional oversight of the laboratory services associated with field activities.

h. The USAF Institute for Occupational Health (radiochemistry laboratory) can provide definitive identification of radiological samples.

i. The USAF BEE units can provide field confirmatory identification of chemical, biological, and radiological agents.

j. The USAF Biological Augmentation Team. The BAT can provide commanders with field confirmatory identification with rapid, specific pathogen identification.

## **9. Laboratory Response Network**

a. The LRN was established in 1999 by the CDC. The mission of the LRN is to “maintain an integrated national and international network of laboratories that are fully equipped to respond quickly to acts of chemical or biological terrorism, emerging infectious diseases, and other public health threats and emergencies.” There are 149 laboratories in the LRN. The LRN includes state and local public health, veterinary, military, and international laboratories.

b. The LRN is an early warning network to detect the covert use of pathogenic agents. It uses procedures established by the CDC and is based on grouping laboratories into one of four different levels, A through D, according to their ability to support the diagnostic needs presented by a bioterrorism event.

c. Level A laboratories have minimal agent identification capabilities. Their primary role is to rule out and refer to their nearest Level B laboratory. Level B laboratories perform identification, confirmation, and susceptibility testing. Levels A and B are designated as sentinel laboratories under the new LRN (see Figure VII-2). Level C laboratories include state and other large-facility laboratories with advanced capacity for testing to include dome molecular techniques and are designated as a reference laboratory. The Armed Forces Institute of Pathology has a level C laboratory. Level D laboratories include the CDC and USAMRIID and are designated as national laboratories. These sites have Biological Safety Level 4 laboratories and special surge capacity, as well as advanced molecular typing techniques. Recognizing that most DOD clinical laboratories currently have microbiological capability participate in LRN, all operate at least at the sentinel level while medical centers participate at the reference level.

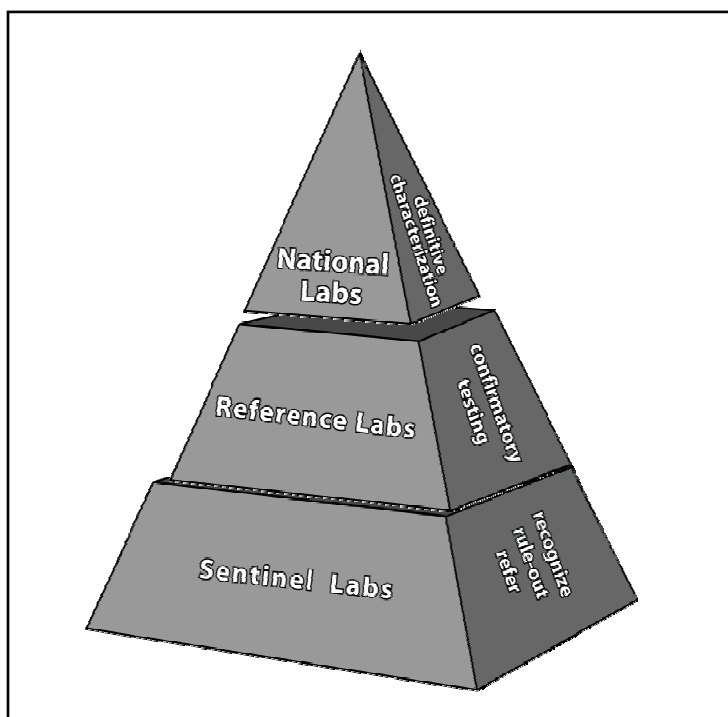

Figure VII-2. The “New” Laboratory Reference Network Designation

**This page intentionally left blank.**

## Chapter VIII

# COMBAT AND OPERATIONAL STRESS CONTROL

### 1. General

a. The invisible, pervasive nature of CBRN weapons creates a high degree of uncertainty and ambiguity with fertile opportunity for false alarms, rumors, and maladaptive stress reactions. The terrible nature of some of these weapons will create fear for the future, the homeland, and perhaps even for the survival of civilization. The CBRN threats, regardless of origin, present significant combat and operational stress (COS) to US forces.

b. The CBRN environment presents multiple challenges to military operations when considering COS. The perception of a CBRN threat, whether real or not, in a high COS environment placing Service members at high risk of suffering COSR. Therefore, commanders and leaders must take actions to prevent and reduce the potential numbers of COSR casualty cases. Working in an actual CBRN environment poses both a real and perceived danger to Service members conducting military operations. Pseudo symptoms may be experienced by those believing they have been exposed or simply overwhelmed by the operational stressors resulting from CBRN use. Whether the threat is real or perceived or working in an actual CBRN environment, the protective measures alone can be a significant stressor to Service members required to utilize these protective measures.

c. The symptoms and physical signs caused by excessive stress are similar to some signs of true CBRN agent injury. Therefore, far forward COS triage is essential to prevent over evacuation and loss of the individual to the unit. For details on provision of COSC see FM 6-22.5/MCRP 6-11C/NTTP 1-15M; FM 4-02.51; and FM 6-22.5.

d. The key to addressing COSR resulting from CBRN operations is resiliency training in preparation for actual engagements. Leaderships must develop a CBRN training program prior to deployment that will build confidence in equipment and unit capabilities. This leads to cohesion and *esprit de corps*, which is a primary ingredient in COSC.

e. The devastation of high-yield explosive devices along with the resultant casualties can be overwhelming for Service members who are called upon to respond to such events. The sheer magnitude of a high yield explosive can cause significant COSR in affected units and organizations, whether it is used in a terrorist strike or as part of ongoing combat operations.

f. For troops with adequate protective equipment, the CBRN environment serves primarily as an operational challenge which makes combat missions much more difficult and time consuming. They also produce high rates of COSRs (most of whom RTD if properly treated).

### 2. Combat and Operational Stress Reaction

a. Using protective clothing and other defensive measures against CBRN warfare adds to physical fatigue, primarily because of heat, visual and auditory restriction, and impeded movement. The necessity for precautions will further reduce the time available for rest and sleep, increasing exhaustion. The threat of CBRN warfare is a major source of COS whether or not CBRN agents are actually used. The following adds significant COS to the physical and psychological stress of MOPP—

- Associated fear of the unknown.
- High degree of ambiguity in detecting the threat.

- Uncertain short- and long-term effects of CBRN weapons.
- b. Stress itself contributes greatly to fatigue. The CBRN COSR may include—
- (1) Hypochondriasis. Service members may hyperalert to physical sensations, looking for warning signs. They will find things that worry them and will bring them to the doctor or medical personnel for reassurance or in hope of being sent to safety. This trend is generally observed by increased rates of sick call.
  - (2) Depression or simple exhaustion. Uncertainty, lack of confidence in equipment and leaders, assuming a passive defensive posture, and new or surprise weapons all tend to increase COSR symptoms.
  - (3) Hysteria. This is a COSR with physical symptoms that mimic real CBRN injury. The early US Army World War I ratio (in supposedly well-trained but inexperienced troops) was two *gas mania* cases for every one true exposure case (a 2:1 ratio). Epidemic hysteria can occur as the first anxious person hyperventilates (breathes too fast, gets light-headed, and has *pins and needles* sensations and muscle tenseness in face, fingers, and toes). Others, seeing this and believing him to be a true gas casualty, become anxious and hyperventilate, too.
  - (4) Panic flight. This may also be epidemic. It occurs when a group feels threatened, unprepared, and believes that the only defense is immediate flight. Some event causes one Service member to run, after which the others in the group panic and run wildly.
  - (5) Anxiety and *phobic* avoidance. Service members may refuse to go into places or to use equipment which is wrongly believed to be contaminated. Even when they go, they may be too anxious and cautious to perform well. They may shun people who are believed to be contagious or contaminated.
  - (6) Obsessive compulsive decontamination (*obsessive-compulsive* cleaning). This wastes time and scarce supplies. This can even cause dermatologic problems if Service members use caustic decontamination chemicals on their skin.
  - (7) Congregating in safe areas. Service members will naturally find excuses to stay in collective protection or safe areas. Headquarters personnel in such protection areas may get out of touch with the troops in the field. Medical teams which must work in collective protection areas may find many nonpatients giving reasons to join those who are working inside and being difficult to move out. The misconduct stress behavior version of this is desertion to hide in safe areas.
  - (8) Stealing protective equipment. If there is not enough protective equipment or collective protection to go around, another potential misconduct stress behavior is stealing from or killing others to take over their protection.
  - (9) Paranoia and suspiciousness. Vision and hearing are impaired in MOPP and everyone looks alike. Even friends may not be readily identified. People tend to develop a *paranoid* suspicion of the strange, monster-like figures; they may become jumpy and shoot at shapes or sounds without checking first. This requires emphasis on vehicle and other target identification training, challenge procedures, and passwords. Identifying labels may have to be added to personalize the MOPP gear.
  - (10) Malingering. Service members who deliberately fake CBRN injury, or who self-inflict minor chemical injuries to gain evacuation are malingering, a misconduct stress behavior. Exposing one's radiation dosimeter to radiation artificially in order to raise the dose and be relieved of duty also is malingering.

### 3. Combat and Operational Stress Control Under Reactions

Under reactions may be more likely than overreaction in some situations and may include—

- Denial. Things are too horrible for a Service member to think about, so he just thinks about something else, to assist him in coping with the threatening environment.
- Rationalization. Service members may believe that no one would be so crazy as to use such terrible weapons, so why should they waste their time preparing and training for them? This type of COSR may result in lack of preparation or preparedness in the event of actual CBRN use.
- Fatalism. Service members may believe that if anyone is so crazy as to use these weapons, they are so terrible that they cannot protect themselves anyway. Therefore, they see no value in preparing and training to protect themselves in the event of their use.
- False alarm. If there is a threat situation with frequent false alarms, troops may neglect alerts and fail to react, believing it is just another false alarm when, in fact, it is the real thing.
- Overconfidence. Service members may feel overly confident about the capability of their equipment and/or procedures to provide an early warning of the impending threat. This over confidence may result in Service members not taking all necessary and prescribed precautions.
- Utopia. Service members may feel that future research, medications, and/or treatments will reduce and eliminate the threat in the near future, so they do not feel it is necessary to train to protect themselves from exposure to CBRN agents.

### 4. Combat and Operational Stress Reaction Leader Risks

a. Mission oriented protective posture requires much more active leadership. It hides the usual nonverbal cues of alertness, understanding, and readiness to act which leaders normally rely on. Leaders must move around, touch to get attention, and insist on information and confirmation. This movement increases the leader's risk of heat exhaustion, carelessness, and being accidentally shot by a nervous Service member. Accidental fratricide (killing of leaders and other friendly personnel) has been alarmingly high in MOPP field exercises which use the multiple integrated laser engagement simulation devices. The same problem occurs in jungle and night fighting where vision and hearing are also reduced. Fratricide must be prevented by careful adherence to the TSOP, coordination between units, target identification, and the use of challenge procedures. For more information, refer to FM 6-22.5.

b. Mission-oriented protective posture interferes with normal friendly support, such as conversation, sharing food, or facial expressions such as smiling. As a result of the sensory and social isolation and encapsulation, Service members tend to feel alone. They may feel surrounded by a totally hostile world in which even the air they breathe is against them. This isolation tends to make people become passive, insecure, and at high risk for COSRs unless it is actively counteracted. It requires a more active, verbal, and deliberate effort to maintain a sense of comradeship, unit cohesion, and *esprit de corps*.

### 5. Combat and Operational Stress Reaction Leadership Actions

a. The former Soviet Union, through their military literature, recognized and valued the threat of CBRN warfare to *demoralize through rumor*. These rumors were concerned with family and home, as well as with self and unit, in any perceived CBRN war. Current threats,

whether organized military organizations or insurgent opposition, have not forgotten this lesson.

b. Commanders must counsel those who originate and/or spread rumors and ensure that the best available information is provided through the chain of command and is disseminated to every Service member. Covering up or withholding information can permanently destroy the leadership's credibility. Utilization of unit or attached public affairs personnel and a solid command information program (CIP) can prevent rumors or stop them from spreading. A wide range of CIP products are available through public affairs channels.

c. Service members who have an understanding or situational awareness of mission requirements tend to exhibit less anxiety while executing assigned tasks. Keep information flowing, dispel myths, and control rumors by—

(1) Discussing the mission and its possible long-term implications upfront. Within OPSEC requirements, include such information as—

- Mission objectives.
- Expected duration.
- Known CBRN threats and countermeasures.

(2) Focusing on unit cohesion. Emphasize that the unit will face CBRN threats together. Cohesion is the single best predictor of an organization's ability to engage and sustain operations in high stress environments.

(3) Conducting resiliency training. Successful COSC in a CBRN environment is directly related to the amount of preparation and training conducted in the development of equipment confidence and its ability to sustain prolonged usage. Training should be routine and conducted before deployment orders are issued. Use training procedures that—

- Review history on CBRN weapons employment used by the known threat.
- Emphasize the buddy system as a means of keeping watch for each other. Peer support is a key element in reducing COSR at the unit level. Unit peers are essential in monitoring the health and reactions of fellow Service members and are key in recognizing COSR quickly so that preventive or mitigating measures can be employed.
- Develop CBRN SOPs. Having known standards published to and practiced by unit personnel can have a significant impact in the overall stress or anxiety of Service members facing operations in a CBRN environment. The SOPs and training develop cohesion and confidence in unit personnel. The SOPs should include the following:
  - Train in the protective mask often. It takes repeated wear and time to acclimate and get over the claustrophobic feeling of wearing the mask. The training can be conducted during a variety of activities.
  - Have personnel wear the mask often in garrison or during lulls in other activities, even at desk jobs. If on average, one person in five wears the mask, on a rotational basis, at any given time, everyone will quickly become accustomed to wearing it.
  - Periodic prolonged wear (8 hours or more) helps Service members gain confidence and realize that they can tolerate the discomfort.
  - Have personnel wear the mask while performing combat-related (mission essential) tasks.
  - Training in MOPP Level 4 will increase personnel confidence in their ability to wear the ensemble.



- Ensure Sleep Plans are Safely Practiced. Have everyone practice wearing the mask while sleeping. Ensure personnel only sleep in safe places; do not allow personnel to sleep under or near vehicles or other motorized machinery. Require ground guides for all vehicles in the unit bivouac area. According to the new US Army sleep guidance plan, each Soldier must (when possible) get at least 7 to 8 hours of uninterrupted sleep during every 24-hour period.

## **6. Individual Responsibilities**

a. Follow Orders. By following orders, individuals can increase their ability to cope with and prevent combat and operational stress-related conditions. Coping with the stresses of a CBRN environment requires extra individual action. Concentrate on the positive aspects of survival, not the negatives of illness or death.

b. Train. Use every opportunity to wear the protective mask or the entire MOPP ensemble during training, when permitted. You build self-confidence and endurance by frequently training with your protective mask, or at MOPP Level 4. Perform refresher training in basic CBRN survival skills.

c. Use Buddy System. Use the buddy system to increase your ability to survive. Service members looking out for each other give a sense of security that relieves stress. Looking out for each other improves every individual's ability to perform duties.

## **7. Behavioral Health Personnel Responsibilities**

a. Staffing for BH/COSC. The following US Army activities or units provide COSC support within an AO—

- Brigade BH section assigned to the brigade support battalion, medical company for the brigade combat team (BCT).
- Area support medical company BH section for personnel assigned to units at echelons above brigade (EAB).
- Limited BH/neuropsychiatry services at each CSH provided by a BH nurse and BH specialist for inpatients and hospital staff (supported by the medical detachment, as necessary).
- Medical detachment, combat stress control provides BH/COSC direct support to BCTs and for personnel at EAB on an area support basis.

b. Conduct Preventive Activities. In a CBRN environment, prevention is the most economical means of controlling COSR. Behavioral health personnel must begin consultation services before CBRN weapons/agents have been employed.

c. Control Combat and Operational Stress Reactions. Individuals with COSRs reactions require prompt intervention. The evaluation of overstressed personnel is difficult but not impossible when the Service members and the evaluator are in MOPP. The primary method of BH evaluation is the interview and mental status examination.

## **8. Conducting Combat and Operational Stress Control in a CBRN Environment**

a. Conducting COSC activities in a CBRN environment (like COSC in all military operations) is the commander's responsibility. Combat and operational stress control support is achieved through the aid of many resources available to command, to include

military BH assets. The key to successful COSC operations in a CBRN environment is the prevention activities conducted prior to actual CBRN events.

b. Combat and operational stress control operations, like any activity engaged in a CBRN environment, will take additional time and tax available resources in its implementation. Leadership identifies all available COSC providers and assets and seeks consultation in addressing and controlling COSRs reactions resulting from CBRN operations. As with any military operation, preferably, COSC assets should integrate and consolidate their resources to provide in depth full spectrum COSC/BH care. This is especially true in CBRN environments.

c. The CBRN COSC activities blends existing COSC functional areas to create a flexible set of interventions specifically focused on stress management for units and Service members following CBRN use and working in a CBRN environment. Successful CBRN COSC activities will require a thorough understanding of all the COSC functional areas (FM 4-02.51), but will be based on the following guidelines—

d. The COSC functional areas of reconstitution and reconditioning will require a secure, uncontaminated area to be executed. These functional areas will not likely be done in a CBRN environment due to mission requirements and the length of time to conduct. Leaders, however, should review these functional areas to obtain familiarity with their concept.

e. The CBRN COSC unit needs assessment (UNA) is a systematic process for identifying the COSC needs of units. The same tools utilized in non-CBRN environments can be used successfully in a CBRN UNA. Leaders should coordinate UNAs with available BH assets who have specialized training in providing these services. When conducting a CBRN COSC UNA, consider the following:

- They should not interrupt or intrude on current or planned CBRN operations.
- The UNAs should be conducted in a decontaminated or a clean location that is secure and provides protection from ongoing threats, toxins, and harm.
- Remember that the UNA is a unit-level assessment and does not substitute for individual-level screenings or COSC triage.

f. Consultation and education activities prior to CBRN events prepare leaders to seamlessly institute COSC interventions while continuing to conduct military operations. The 6 R's (remind, reassure, rest, replenish, restore, and return) are a good model to build on. Leaders should consider interventions that target—

- Battlefield ethics.
- Safety, security, and survival.
- Food, hydration, clothing, and shelter.
- Sleep.
- Medication (replace medications destroyed or lost).
- Orientation of unit/Service members to developing situation.
- Restoration of communication with unit, dependents, friends, and community.

g. The CBRN COSC consultation and education to Service members should emphasize normalizing the common reactions of CBRN events, improving their coping skills, enhancing self-care, facilitating recognition of significant problems, and increasing knowledge of and access to COSC services. Post-CBRN UNAs guide further consultation and education efforts.

h. The CBRN traumatic event management (TEM) will require specialized COSC services for potentially traumatizing events (PTEs) that occur while operating in a CBRN environment. The PTEs are events that cause individuals or groups to experience intense feelings of terror, horror, helplessness, and/or hopelessness. The TEM will require assessment of the PTE that occurred and a tailored intervention at the group or individual level to stabilize, mitigate and support the resulting emotional and psychological reactions. Leaders should contact available COSC assets to request a TEM assessment and intervention when PTEs occur. The CBRN PTEs that may require TEM include—

- First exposure to a CBRN event.
- Witness mass injury or death resulting from CBRN attack.
- Unexpected casualties resulting from accidental CBRN exposure or equipment failure.

i. The COSC triage process is the sorting of Service members based on an assessment of their needs and capabilities, and the location where they can best be managed in keeping with the COSC management principles of brevity, immediacy, contact, expectancy, proximity, and simplicity (BICEPS).

j. Service members may require COSC triage in CBRN environments. The CBRN COSC triage follows the same categories and process as traditional triage in non-CBRN environments. There are four COSC triage categories in the US Army—help in place, rest, hold or refer.

k. The assessment includes an evaluation of the Service member's physical and BH needs, potential medical emergencies, and other safety risks. Assessment should be performed by providers according to their professional training, expertise, and standards. The CBRN COSC triage, like COSC triage, will—

- Determine what intervention techniques best address the Service member's needs and functional capabilities.
- Consider the needs, abilities, and the safety of the Service member. It should also consider the unit's capacity to provide COSC interventions based on its OPTEMPO, mission, resources, response to prior consultations, and willingness to participate in COSC interventions.

l. The CBRN COSC triage considerations may include—

- Persistent or worsening traumatic stress reactions (such as dissociation, panic, autonomic arousal, and cognitive impairment).
- Significant functional impairments (such as role/work relationships).
- Dangerousness (suicidal or violent ideation, plan, and/or intent).
- Severe psychiatric comorbidity (such as psychotic spectrum disorder, substance use disorder, or abuse).
- Maladaptive coping strategies (such as pattern of impulsivity or social withdrawal under stress).
- New or evolving psychosocial stressors.
- Poor social support.
- Failure to respond to acute supportive interventions.
- Exacerbation of preexisting psychiatric conditions.
- Service members request for assessment.

m. The CBRN COSC stabilization is the acute management of disruptive behavior resulting from COSR and/or a behavioral disorder resulting from the stressors of working in

or exposure to a CBRN environment. Such behaviors can severely impact unit functioning by posing a danger to the Service member and/or others. Leadership should be prepared to provide or coordinate stabilization services if required. Precoordination with medical unit personnel promotes safe management.

n. Service members operating in a CBRN environment may require COSC restoration services as a result of COSR. Service member restoration is normally a 24- to 72-hour (1- to 3-day) program in which Service members with COSR receive treatment. Service member restoration is accomplished using the principles of BICEPS and the 6 R's. Service member restoration is typically provided by COSC assets, but can be managed by organic medical personnel or religious support personnel.

o. The measures below are applicable to Service members with COSR in a CBRN environment. The provider should be familiar with the 6 R's and with BICEPS. In keeping with restorative efforts, the provider focuses on the following measures through leadership consultation, Service member education, and/or direct management:

- Minimizing exposure of Service members with COSR to further PTE.
- Reducing physiological arousal.
- Mobilizing support for those who are most distressed.
- Providing information and fostering communication and education.
- Using effective risk communication techniques.
- Proving assurance/reassurance.
- Mitigating fear and anxiety.
- Encouraging sleep hygiene.
- Reestablishing routines.
- Promoting exercise and nutrition.
- Encouraging self-paced emotional ventilation.
- Discouraging use of alcohol/substances.

p. The CBRN BH treatment exists when there is an explicit therapist-patient or therapist-client relationship. Behavioral health treatment is provided for Service members with behavioral disorders to sustain them on duty or to stabilize them for referral/transfer. This is usually brief, time-limited treatment as dictated by the operational situation. The BH treatment includes counseling, psychotherapy, behavior therapy, occupational therapy, and medication therapy. Treatment assumes an ongoing process of evaluation and may include assessment modalities such as psychometric testing, neuropsychological testing, laboratory and radiological examination, and COSC providers' discipline-specific evaluations.

q. In the event a Service member requires BH treatment in a CBRN environment, regardless if the BH diagnosis is chronic or acute in origin, services should be managed by COSC/BH providers operating in support of the Service members unit or organization.

## Chapter IX

# HEALTH SERVICE LOGISTICS SUPPORT

### 1. General

a. United States military doctrine specifies that each Service will provide its own logistical support except when logistics is otherwise provided for by agreements with national agencies or allies or assignments of common, joint, or cross-servicing logistics.

b. The CCDR has the authority to issue and implement directives to transfer logistics functions between or among Service components within the AOR under wartime or crisis conditions. This authority is designed to ensure effective execution of approved operations plans, provide effectiveness and economy in OPLANs, and prevent unnecessary duplication of facilities and functions among the Service components. The CCDRs cannot enter into multinational relationships that are contrary to US policy without the President and SecDef direction.

c. The DOD has designated the US Army as the executive agent for the DOD Chemical and Biological Defense Research, Development, and Acquisition Program. The US Army implements this responsibility through a joint Service agreement and chairmanship of a joint Service review group and a joint panel on chemical biological defense, reporting to the joint logistics commanders. The US Army also chairs a joint Service coordination committee to assist in chemical defense equipment logistics prioritization and allocation of resources worldwide.

d. The Assistant Secretary of Defense for Health Affairs establishes health policy and provides oversight of health policies being implemented by the Services' Surgeons General or the Medical Officer of the USMC. Within the DOD, two organizations play a prominent role in management of Class VIII materiel: the Defense Logistics Agency and the Defense Medical Standardization Board (DMSB). Upon the recommendation of the CCDRs, the Chairman of the Joint Chiefs of Staff (CJCS) advises the SecDef on establishing a theater evacuation policy. The Services' Surgeons General or the Medical Officer of the USMC provide guidance on HSL policies to be implemented within their Services. The CCDR has authority within his AOR for the execution of the HSL mission.

e. The command surgeon is the CCDR's principal FHP and HSS advisor in theater and will normally serve as the JFS during CBRN operations. The command surgeon supervises the planning and execution of the HSS mission. The Geneva Conventions provide specific safeguards which apply to HSL materiel and personnel. Refer to STANAG 2827 for more information.

### 2. Logistics Support in a Chemical, Biological, Radiological, and Nuclear Environment

a. Logistics organizations provide support and assistance to sustain forces during a CBRN incident. This support is primarily in the functions of supply, maintenance, transportation, CE, health services, and services associated with nonmateriel support actions. Combatant commanders exercise directive authority over logistics through Service component commanders so that they can shift support effort to the critical place and time. Combatant commanders will oversee Class VIII operations of their designated theater lead agent for medical materiel. Logistics commanders must initiate CBRN procedures to limit exposure of their units and facilities to CBRN attacks and to protect personnel and supplies from CBRN contamination. Where protection is not assured, CBRN defense calls for

decontamination of critical support materiel. Most logistics functions become more difficult under CBRN conditions. Medical units must implement systems to treat and evacuate larger numbers of casualties, who may also require special handling before, during, and after treatment. The supply system must provide needed protective clothing, shelters, and water to support the operations. The CCDR identifies functions and services available from host nation assets. United States forces may train and equip personnel from US, coalition, and host nation forces to ensure their survival.

b. Health service logistics support provides the required Class VIII materiel and equipment when and where it is needed on the battlefield. In a joint operation or during a CBRN incident, the CCDR may exercise directive authority over the joint Class VIII system by designating a single integrated medical logistics manager to oversee Class VIII efforts.

c. The HSL is one of the functional areas of HSS. As such, it requires comprehensive planning for inclusion in the HSS estimate and plan which supports the CCDR's OPLAN. One of HSL's mission is to provide Class VIII supplies and equipment to include medical support peculiar to CBRN operations.

### **3. Health Service Logistics Support Considerations in a Chemical, Biological, Radiological, and Nuclear Environment**

a. The ability to sustain CBRN operations with an appropriate level of logistics support is vital to operational success. Operations in a CBRN environment can place significant burdens on the logistics system. Plans supporting deployment, reception, staging, onward movement and integration, sustainment and redeployment must continually be reviewed. Health service logistics personnel must train and prepare to operate in all battlefield situations. Logistics planning and training includes considerations for reducing vulnerabilities to a CBRN attack and ensuring logistics support operations. For detailed information on providing HSL see JP 4-02, and FM 4-02.1.

b. Regardless of the operational theater, medical supplies and equipment must have environmentally controlled warehouses or covered shelters to reduce the vulnerability to contamination. Host nation support agreements will play a large part in securing needed protection for these supply items.

c. When assessing the likely nature and frequency of possible attacks on logistics facilities, the CCDRs should consider the number of available delivery means, chemical and biological warheads, and the ability of the adversary to deliver an agent to significantly disrupt operations. In planning logistics sites, the attack range of adversary air and surface weapons delivery systems armed with chemical, biological, or possibly nuclear warheads should be assessed. In a CBRN environment, CCDRs are responsible for sustainability, survivability, flexibility, and responsiveness of logistics supplies while the command surgeon is responsible for the protection of medical supplies and equipment. Disruptions of the MSR and communications systems are to be expected.

d. Blood and blood components are valuable commodities of medical supply and require special procedures for handling and protection. Storage, potency periods, protection, inventory management, and innovative technology all play an important part in managing the blood supply in a CBRN environment. Blood support must be a highly organized and coordinated effort on the part of HSL, operations and plans, blood bank, laboratory, transportation, and medical care personnel. The joint blood program office (JBPO) is responsible for the joint blood program management in a theater. The JBPO functions as part of the CCDR's command surgeon's office but may establish an area joint blood program office for regional blood management.

e. The medical platoon (Role 1 MTF) is authorized two chemical agent patient treatment MESs and one chemical agent patient decontamination MES. Operating in a CBRN environment requires the issue of the chemical patient treatment MES and the chemical patient decontamination MES. Each chemical agent patient treatment MES has enough supplies to treat 30 patients. Each chemical agent patient decontamination MES has enough consumable supplies to decontaminate 60 patients.

---

Note: Although the chlorine granules in the chemical agent patient decontamination MES are used to prepare the hypochlorite solutions for use to decontaminate patients, the preferred method/means is soap and water. Refer to Chapter V for more information on patient decontamination.

---

f. Roles 2 and 3 MTFs are authorized five chemical agent patient treatment MESs and three chemical agent patient decontamination MESs. The MESs are for use at the Role 2 MTF PDS.

#### **4. Protecting Supplies in Storage**

Protecting supplies can be accomplished by placing them under tents, using plastic wraps, or providing storage warehouses with CB filtered-conditioned (heated or cooled) air systems. Wrapping supplies in two layers of plastic material provides protection from most agents for a short period of time; the thicker the plastic material, the longer the protection. Effectiveness of protective procedures can be checked by placing M9 detector paper on supplies and between layers of the covering. Protection from the thermal and blast effects of nuclear detonations require much more elaborate measures. Placing the supplies in trenches, inside earthen berms, behind stonewalls, or in other field expedient facilities will enhance the protective posture of supplies from the nuclear effects. Even when taking these protective measures, a quantity of supplies will become contaminated and must be replaced. Plans should be in place for replacement of damaged items.

#### **5. Protecting Supplies During Shipment**

During shipment, supplies are protected by placement inside MILVANs, in covered enclosed vehicles or by wrapping them in several layers of plastic, in tarpaulins or in other protective material. To monitor exposure of supplies to CW agents during shipment, place M9 detector paper between the wrappings. If exposure is limited to the outer layer, simple removal of this layer may be all that is required to eliminate the contamination. Decontamination is much easier when the supplies and equipment have been protected by multilayers of overwraps.

#### **6. Movement Control**

a. Movement control must coordinate the employment of all means of transportation, including that provided by allies or host nations to support the CCDRs' concept of operations. The USTRANSCOM is the DOD single manager for transportation that provides air, land, and sea transportation to meet national security objectives through the range of military operations. It orchestrates all transportation aspects of planning and execution with the joint staff and the appropriate combatant and Service component commands. The USTRANSCOM is composed of three component commands: The USAF's Air Mobility Command, the Navy's Military Sealift Command, and the Army's Surface Deployment and Distribution Command (SDDC). The Commander, USTRANSCOM, as the single transportation manager, will provide for proper liaison with the CCDRs for movement of

decontaminated personnel and materiel in theater. The CCDRs will exercise control over intratheater movement. Whatever unique circumstances prevail in a theater, logistics plans should provide CCDRs with the highest practicable degree of influence or control over movement. Refer to JP 4-0 for more information.

b. Planning airlift operations is a complicated process involving numerous interdependent functions. These range from such things as assuring airlift facilities are capable of supporting a CBRN operation to selecting the most appropriate airlift for that operation. Airlift planners must be thoroughly familiar with each Service component's unique airlift capabilities, as well as those of common-user airlift. They must comprehend the nature of the CBRN threat to airlift and coordinate effective threat countermeasures. Finally, the entire airlift operation requires detailed planning, to include coordination of appropriate airspace control measures and communication procedures. The following are general considerations for airlift planners:

- (1) Planners must know the capabilities of each airlift facility in the theater.
- (2) The supported Service component is responsible for the movement of personnel and cargo to the onload site and forward after off-loading.
- (3) The effectiveness of airlift is dependent on the number and type of aerial ports available within the theater. The USTRANSCOM designates peacetime aerial ports.
- (4) The CCDR designates wartime and contingency aerial ports in coordination with Commander, USTRANSCOM and appropriate host nation authorities.
- (5) All echelons must plan for air base defense to protect airlift aircraft, aircrews, support personnel, and base facilities. This may include protection against conventional air-to-surface munitions, as well as CBRN weapons and unconventional warfare forces.
- (6) Airlift plans must integrate international, host nation, and military airspace control procedures and regulations.
- (7) Timely intelligence is essential to airlift mission planning. Airlift operations require considerable intelligence support to reduce their vulnerability.
- (8) Airlift aircraft are very vulnerable to contamination.



## Chapter X HOMELAND DEFENSE

### 1. General

Although homeland security is not a specific military mission, medical commanders must plan for and be prepared to support a primary agency such as the FBI or Federal Emergency Management Agency (FEMA) in response to a CBRN event. Various federal statutory authorities and policies provide the basis for federal actions and activities in the context of domestic incident management. The National Response Framework (NRF) uses the foundation provided by the Homeland Security Act, Homeland Security Presidential Directive (HSPD) -5, and the Robert T. Stafford Disaster Relief and Emergency Assistance Act (Stafford Act) to provide a comprehensive, all-hazards approach to domestic incident management. For more information on CBRN response guidelines, see the NRF and DODI 2000.18.

---

Note: This chapter does not replace AFTTP 3-42.32.

---

### 2. Homeland Defense Chemical, Biological, Radiological, Nuclear Response

a. In accordance with references DODD 2000.12; DODI 2000.16; and the Quadrennial Defense Review Report, it is DOD policy that—

(1) The DOD components under the command and control of US Northern Command (USNORTHCOM) in CONUS has the responsibility to support and assist civil authorities as directed and in coordination with the NRF in defense support of civil authorities (DSCA) and CM missions. These missions may include response, mitigation, and recovery assistance for natural and man-made disasters, which may involve CBRN-related incidents.

(2) Commanders implement multilayered approaches of active and passive deterrence, including dedicating resources to CM.

(3) Installation commanders are prepared to respond to and protect DOD personnel and installations from the effects of a CBRN incident.

(4) Commanders at all levels have the authority and responsibility to protect persons and property subject to their control.

b. The DOD primarily maintains readiness to defend our country. The DOD also maintains readiness to provide DSCA when directed to do so by the President. The role of DOD in homeland security continues to gain definition. Currently, homeland security is a concerted national effort to prevent terrorist attacks within the US, reduce US vulnerability to terrorism, minimize damage, and assist in the recovery from attacks.

c. In recognition of the unique nature and challenges of responding to a domestic CBRN event, the DOD established the Joint Task Force-Civil Support (JTF-CS), a standing headquarters element subordinate to USNORTHCOM to plan for and integrate DOD's support to the primary agency for domestic CBRN CM. On a day-to-day basis, JTF-CS is involved in CBRN CM doctrine development, training and exercise management, plans development and review, and requirements identification. It is comprised of active, reserve, and National Guard personnel and is designed to be a C2 headquarters without assigned forces or dedicated transportation. During a CBRN event, JTF-CS would report to USNORTHCOM and would provide military assistance to civil authorities.

d. The United States Pacific Command and the United States Southern Command have parallel responsibilities for providing DSCA for states, territories, and possessions outside the CONUS and United States Joint Forces Command (USJFCOM) may be a principal force provider. The USJFCOM, in turn, provides technical advice and assistance to CCDRs in chief conducting CM operations in response to CBRN incidents OCONUS.

e. Department of Defense support of a federal response to a domestic terrorism incident will be personally managed by the SecDef, with the assistance of the CJCS. The DOD crisis management response will be provided through the national interagency terrorism response system. The DOD response forces will be employed either under the operational control of the joint special operations task force or a response task force assigned to the appropriate CCDR.

f. Principles of Civil Support have the following considerations—

(1) The President and the SecDef establish priorities and determine what DOD resources will be made available for civil support. The CCDRs ensure that DOD resources are used judiciously by adhering to the civil support principles. Civil resources are applied first in meeting requirements of civil authorities.

(2) Department of Defense resources are provided only when response or recovery requirements are beyond the capabilities of civil authorities (as determined by the DHS/FEMA or another primary agency for emergency response).

(3) Specialized capabilities of the DOD (for example, airlift) are used efficiently.

(4) Military forces shall remain under military C2 under the authority of the DOD executive agent at all times.

(5) Department of Defense components shall not perform any function of the civil government unless absolutely necessary and then only on a temporary basis under conditions of immediate response.

g. When a CBRN event occurs on a military installation, the installation medical authority (IMA) provides the HSS initial response to the event site. Request for assistance from deployable HSS organizations and staffs are initiated by the IMA through military channels. Refer to AR 40-13 for more information.

h. The President will direct any DOD response in support of a primary agency to a CBRN event. The Presidential directive to assist will be passed down through military channels to the appropriate HSS organization for response. The HSS response may be in the form of special medical augmentation response team (SMART) support or other specialized response teams from US Army Medical Command (USAMEDCOM) resources or US Army Forces Command (FORSCOM) HSS TOE units. Responding resources will provide HSS to support the primary agency or civilian public health agencies and/or organizations, emergency medical services (ambulance crews), or MTFs when directed. Health service support may be in coordination with DOD C2 established by USNORTHCOM.

i. The HSS response may include, but not be limited to—

(1) Providing medical care to casualties at the incident casualty decontamination site and supervising the casualty decontamination process to ensure that no further injury is caused to the casualty.

(2) Providing en route care for patients from the incident site to an MTF or designated location for further care. Normally, TOE medical evacuation assets are not used but HSS personnel provide the en route care on locally provided transport vehicles.

(3) Providing guidance to local responders in the management of CBRN casualties. This guidance may be on the correct use of antidotes, chemoprophylaxis, prevention of contamination spread in the MTF, casualty decontamination at the MTF, and other related medical management procedures.

(4) Identifying suspect chemical, biological, or radiological materials used in the event.

(5) Providing guidance on the application of standard precautions for CBRN, especially preventive measures to prevent spread of contagious agents.

(6) Managing, triaging, and treating mass casualties.

j. For more information on specific Services tasks list see Appendix C.

k. Installation or base protection is a homeland defense mission. Detailed doctrine on medical support requirements are outlined in FM 3-11.4 (FM 3-4)/MCWP 3-37.2/NTTP 3-11.27/AFTTP (I) 3-2.46. Medical treatment facilities have unique capability to support the installation and installation responders through the issue of Medical Chemical, Biological, Radiological, and Nuclear Defense Materiel, planning, and guidance provided by the public health emergency officers (PHEOs), and the application of the full range of available medical capability.

### **3. United States Army Role in Homeland Defense**

a. The DOD created the CBRN consequence management response force (CCMRF), which includes response, medical, and support units that could respond within one to three days to a catastrophic event. The CCMRF is a ready reaction force organized into three task forces comprised largely of active units that total approximately 3,600 troops. This force would report to JTF-CS during an actual event. The units that comprise the CCMRF are not focused exclusively on civil support and can be deployed overseas in support of other requirements. As a result, the units that comprise the CCMRFs are constantly changing.

b. The 20th Support Command (chemical, biological, radiological, nuclear, and high-yield explosives [CBRNE]) is a subordinate command assigned to the FORSCOM. It integrates, coordinates, deploys, and provides trained and ready forces and is prepared to exercise C2 of specialized CBRN operations to joint and Army force commanders. It provides Army commanders, Joint commanders and lead federal agency a full spectrum, expeditionary CBRNE capability, with the capacity to execute simultaneous missions within and outside CONUS. Once final operational capability is reached, this command will be rapidly deployable, equipped with rugged and specialized equipment, and ready to support the DOD worldwide.

c. The US Army North (USARNORTH), the ASCC to USNORTHCOM, conducts homeland defense, civil support operations, and theater security cooperation activities in order to protect the American people and their way of life. On order, USARNORTH commands and controls deployed forces as a JTF or joint force land component command.

### **4. United States Army National Guard Role**

a. In 1998, the DOD commissioned a *tiger team* to develop a strategic plan for integrating National Guard and RC support for response to attacks using WMD. The plan defined a future operational capability based on enhancing RC support to the civil authority in the US in managing the consequences of WMD terrorism. The subsequent approval of

the plan by the Deputy SecDef as Defense Reform Initiative Directive Number 25, together with the Unified Command Plan for Fiscal Year 2000, the Defense Planning Guidance (2002-2007), and the CJCS Contingency Plan 0500-98 charges DOD with the support of domestic CM.

b. The purpose of weapons of mass destruction-civil support team (WMD-CST) is to assess current and projected consequences and identify CBRN agents and substances. The WMD-CST advises on response missions and assists with such measures as requests for additional support. Each team consists of six smaller sections—

- Command.
- Operations.
- Communications.
- Administration and logistics.
- Medical.
- Survey.

(1) These teams have been trained and equipped to provide a technical capability to reach back to other experts who can assist the incident commander (IC). These teams provide a unique military capability. They can deploy rapidly to a suspected or actual terrorist attack, conduct reconnaissance to determine the effects of the attack, provide situational understanding, provide technical consultation to local authorities on the effects of the attack to minimize the impact, and facilitate follow-on military support through validated civilian requests for assistance. Under Title 32, the WMD-CST is assigned to the Governor for state response to support the local IC in CBRN responses. Under Title 10, the WMD-CST may be federalized to support a JTF-CS as part of the overall national response of local, state, and federal assets. For additional information on the WMD-CST, refer to FM 3-11.22.

(2) There are currently 55 WMD-CSTs (one per state/territory; two in California). To date, all of them are on schedule in a phased implementation with 47 of them already certified. As the WMD-CST is on standby 24 hours a day, seven days a week (24/7), the advanced echelon will deploy within 90 minutes of notification and the rest of the team within three hours. This quick response gives the WMD-CST the ability to support the IC with critical information rapidly. The WMD-CST commander can advise the IC as to the type and level of hazard present, possible course of action, and additional National Guard assets that are available.

(3) The WMD-CST is composed of 22 people; 7 officers and 15 enlisted personnel, from both the Army and Air National Guard, with a variety of specialties. Assigned vehicles include a command vehicle, operations van, a communications vehicle called the unified command suite (UCS) (provides a broad range of communications capabilities including satellite communications), and an analytical laboratory system van (contains a full suite of analysis equipment to support the medical team and other general purpose vehicles). The WMD-CST normally deploys using its assigned vehicles, but can be airlifted if required. A deployment distance of up to 250 miles can usually be covered faster by surface travel, given the time required to recall an aircrew and stage an aircraft.

(4) The WMD-CSTs have a unique ability to assess CBRN events. This is accomplished through the expertise of personnel and the use of several computer-based modeling programs. In addition, the survey and medical team's high state of training and advanced technology equipment allow for accurate and timely sample collection and identification of CBRN agents and substances. The WMD-CST also provides the ability to act as a CBRN reconnaissance force that can provide a unique view at the incident site.

(5) The WMD-CST provides assessments and *field* presumptive identification to analyze most CBRN agents and substances. The WMD-CST's sophisticated detection, analytical, and protective equipment allows for operations to take place in environments that contain many different TIM and CBRN materials. The PPEs (such as OSHA Levels A and B) used by WMD-CSTs provide more extensive protection from HAZMAT than does the equipment used by most military units.

(6) The communications capability of the UCS allows any member of the WMD-CST to contact a wide range of technical experts. It also allows the commander to pass information and situation reports up channel to keep the joint force headquarters (JFHQ), National Guard Bureau (NGB), and USNORTHCOM apprised of the current status.

(7) The WMD-CSTs have provided support to civil authorities in every major event since 1999 including Hurricane Katrina, Super Bowls, Columbia shuttle recovery, and Olympic events.

c. Chemical, biological, radiological, nuclear, and high-yield explosives enhanced response force package (CERFP) C2 team.

(1) The CERFP's mission is to provide immediate response capability to the Governor, searching an incident site, including damaged buildings; rescuing any casualties, decontaminating them, and performing medical triage and initial treatment to stabilize them for transport to a medical facility (this includes extracting anyone trapped in the rubble).

(2) The CERFP is composed of four elements staffed by personnel from already established National Guard units. The elements are search and extraction, decontamination, medical, and C2. The CERFP C2 team directs the overall activities of the CERFP and coordinates with the JTF State and the IC. The CERFP search and extraction element mission is assigned to an Army National Guard Engineering Battalion, the decontamination element mission is assigned to an Army National Guard Chemical Battalion, and the medical element mission is assigned to an Air National Guard Medical Group. The security duties are performed by the state National Guard Quick Response Force.

(3) The initial establishment of CERFPs placed at least one in each FEMA region. There are currently 12 validated CERFPs. An additional five CERFPs have been authorized and funded by Congress, to include full-time manning and equipment. When an incident occurs within a team's response area, they are alerted through their state headquarters and mobilized on state active duty. If the incident is located within their state, they would proceed to the incident when directed by their JFHQ. If the incident is located outside of their state, their state headquarters would coordinate with the receiving state under the terms agreed to in the Emergency Management Assistance Compact.

(4) After arriving at the incident site, the C2 team and element commanders coordinate with the IC and JTF Commander to determine how to most effectively employ the CERFP.

(5) Elements of these newly formed CERFP have already responded to incidents of national significance to provide assistance to civil authorities and to mitigate human suffering.

## **5. United States Army Reserve Role**

a. Selected units, such as US Army RC CBRN units, are equipped with additional resources to support casualty decontamination requirements. The mission of these units is

to provide a domestic response capability for casualty decontamination in support of CM operations.

b. These units are equipped with a platoon set of domestic response style equipment to decontaminate both ambulatory and nonambulatory casualties. The set includes a quickly erectable tent with runoff containment included for the actual decontamination, two other tents for sun protection for the workers and victims, showers for washing and rinsing, and roller systems for decontaminating nonambulatory victims.

c. United States Army reserve units, while designed for overseas deployment, have the capability to provide domestic-response casualty decontamination in support of CM. These units are not designed or intended to replace functions carried out under the Incident Command System or functions normally performed by the emergency first-responder community. Instead, these units provide additional capability as needed to support CM. They are not designed for a rapid response, but can be mobilized and deployed within days. The basic functions performed by these units include the following:

- Receive the mission, activate the mobilization plan, and initiate unit movement.
- Conduct decontamination site selection, perimeter, and setup.
- Receive and process casualties from a WMD event.
- Establish a triage site and triage casualties from a WMD event.
- Provide critical medical intervention for casualties suffering from the effects of a CBRN event.
- Provide force protection for individuals working within the decontamination line.
- Establish the domestic decontamination site.
- Conduct casualty gross decontamination.
- Determine the level of decontamination effectiveness on a casualty.
- Conduct nonambulatory casualty gross decontamination.
- Establish a personal property and equipment line and perform decontamination procedures.
- Establish and maintain a hazardous waste site in support of casualty decontamination.
- Establish and maintain a contaminated water collection site in support of casualty decontamination.
- Conduct hazardous wastewater sampling to determine neutralization effectiveness.
- Control runoff of contaminated water in support of casualty decontamination.
- Conduct rehabilitation procedures.

d. The US Army reserve chemical company can decontaminate 40 ambulatory and 20 nonambulatory in one hour and is composed of—

- One hundred and fifteen personnel.
- Three decontamination platoons.
- One reconnaissance platoon.
- Three sets of mass casualty decontamination equipment.

## **6. United States Coast Guard National Strike Force Role**

a. The USCG's National Strike Force's capabilities and responsibilities are available for responding beyond port areas. The strike teams are regularly deployed throughout the US on behalf of both USCG and EPA on-scene coordinators (OSCs). The OSCs can coordinate all federal containment, removal, and disposal efforts and resources during an

incident in a coastal zone. Further, the strike teams are key tactical response units for the EPA to call upon when responding under the NRF Emergency Support Function #10, HAZMAT which provides federal support to state and local governments in response to an actual or potential discharge and/or release of HAZMAT following a major disaster or emergency.

b. The potential exists that the USCG OSCs could very well be the first federal presence in a WMD scenario. Coast Guard OSCs have a preestablished response organization in coastal areas (including rivers and great lakes) with state and local responders, as well as fire and police. The USCG OSCs have experience coordinating support services (National Oceanic and Atmospheric Administration scientific support coordinators, CDC, and the like) and other government agencies with response capabilities into a cohesive command.

## **7. United States Navy Medicine Role**

a. The Navy medicine's tactical medical capabilities, medical and scientific expertise, and federal coordinating centers contribute significantly to homeland security. This includes tactical medical capabilities that can be provided by the FDPMU.

b. The FDPMU mission is to enhance HSS by anticipating and rapidly assessing, preventing, and reducing or controlling health threats in a theater by characterizing those health threats and focusing the efforts of other organic PVNTMED assets to reduce or mitigate the hazards.

c. The FDPMU is a joint service asset. It is specialized PVNTMED support provided to forward deployed US forces and JTF commanders. It is mobile, agile, and rapidly deployable with state-of-the-art detection and diagnostic equipment that yields real-time analytical capabilities. The FDPMU has very small footprint, has self-sustaining consumables for up to 60-days, and has the flexibility to task organize to meet any contingency from small-scale humanitarian support to major combat operations. It is adaptable to operate from fixed or mobile land bases to maritime platforms and requires joint functions and command, control, communications, and computer systems (C4S) integration within the theater.

d. For more information on FDPMU, refer to Appendix D.

## **8. United States Marine Corps Role**

a. In response to Presidential Decision Directive 39, the Commandant of the Marine Corps created CBIRF to counter CBRN terrorist threat. The force is completely self-contained and self-sufficient, capable of deploying anywhere in the world on short notice. The force is a complete unit and contains approximately 450 Marines and Sailors.

b. The CBIRF is capable of rapid response to CBRN threats. Should an incident occur, CBIRF would immediately deploy to the affected site and provide a number of significant capabilities to include coordinating initial relief efforts, security, detection, identification, expert medical advice, mass casualty triage, treatment, decontamination, and stabilization from point of injury until evacuation occurs. The CBIRF has robust reconnaissance, as well as technical rescue capabilities. The CBIRF provides decontamination only for equipment organic to the unit.

c. When directed, the CBIRF forward deploys and/or responds to a credible threat of a CBRN incident in order to assist local, state, or federal agencies and designated CCDRs in the conduct of CM operations. The CBIRF consists of specially trained personnel and

specialized equipment suited for operations in a wide range of contingencies. Through detection, decontamination and emergency medical services, the CBIRF capabilities are intended to minimize the effects of a CBRN incident.

d. For more detailed information about the CBIRF, see Appendix D.

## **9. United States Air Force Role**

a. Operation Noble Eagle is part of the overall plan to protect North America from airborne attack. Under the auspices of North American Aerospace Defense (NORAD) Command, USAF supports the defense plan by organizing, equipping, and operating the air defense forces. The NORAD, a binational command of US and Canadian forces keeps an eye out for missiles and other nonaircraft related issues. The combined air operations center acts as a “battlefield” headquarters for the entire CONUS airspace.

b. The USAF is part of the WMD-CST. The WMD-CST is composed of personnel from both the Army and Air National Guard with a variety of specialties. For more information on WMD-CST, see paragraph 3b above.

c. Air Force home station medical response to CBRN incidents includes the following capabilities—

- 886A, In-Place Patient Decontamination. Capable of being operational in 20 minutes of activation. System is a four lane tent with supplies to decontaminate up to 100 casualties without resupply.
- 886C, Immediate Medical Response Capability. Provides medical supplies to support 300 casualties for the first 48 hours after an event.
- 886D, In-Patient Capability. Capable of augmenting the individual medical readiness for bedded facilities.
- 886E, Pharmacy Response Team. Provides medication and first responder antidotes for CBRN threats.
- 886I, Lab Response Team. Provides a capability through PCR (JBAIDs) for presumptive identification of biological agents. Most of the 52 laboratories also have the M1M Toxin identifier.
- 886H, BEE Detection Team. Capable of using equipment to perform health risk assessments for CBRN threats and TIC/TIMs. Team also has sampling capability.

## **10. Other Department of Defense Response Assets Role (Not Inclusive)**

a. Armed Forces Radiobiology Research Institute. The AFRRRI is a Tri-Service laboratory chartered by the US Congress and is charged with executing the DOD Medical Radiological Defense Research Program.

(1) The AFRRRI maintains a medical radiobiology advisory team (MRAT) to provide state-of-the-art medical radiobiology advice supporting a nuclear accident response. This team consists of physicians and scientists working in radiobiology research. Their mission is to provide the medical units/teams responding to radiobiological emergencies with the most current medical guidance regarding the treatment of radiation casualties. This advice is derived from validated, military-relevant radiobiology research and is within reasonably accepted standards of care.

(2) Subject areas of expertise include, for example, hematology, biological response modifiers, infectious disease, dosimetry, and behavioral analyses. If needed, liaison with other medical centers and laboratories specializing in radiobiology can be



facilitated. Through means of telephone communications (available 24-hours a day), the MRAT provides radiobiology advice to medical staffs and OSCs within a response time of 4 hours. In addition, within 24 hours, the team is prepared to deploy and provide advice at an incident site or MTF. Upon request of the OSC or responsible medical officials, the physician members of the MRAT supplement the designated primary medical treatment teams in the treatment of radiation injuries.

b. Chemical Stockpile Emergency Preparedness Program (CSEPP). The CSEPP is a joint FEMA and Army program in which local assets are supplemented to respond to incidents/accidents at each of the eight chemical-agent stockpile locations. Through this program, the Army provides technical assistance and required resources in developing and implementing emergency-response plans and related preparedness capabilities, integrating the on- and off-post planning process.

c. Special Medical Augmentation Response Team. For detailed information on capabilities of the USAMEDCOM SMARTs, see Appendix D.

d. United States Army Radiological Advisory Medical Team. The US Army maintains a national-level asset called the US Army Radiological Advisory Medical Team (RAMT) for response to nuclear and radiological events. The RAMT can provide military support to civil authorities. The RAMT mission includes 1) expert real-time evaluation of the radiation hazard; 2) advising the OSC, or other responsible official, on contamination control, radiation exposure risks, and protective action guidelines; 3) providing radiological medical support to other response teams entering the hazard zone; and 4) assisting local hospitals with contamination control, patient decontamination, and the medical management of radiation injuries. The RAMT is capable of providing guidance, evaluation, and monitoring of potential health hazards to personnel from radiological contamination or exposure to ionizing radiation.

e. United States Air Force Collectively Protected Expeditionary Medical Support (CPEMEDS). For more information on the capabilities of CPEMEDS, refer to Chapter XI.

f. Medical Chemical, Biological, Radiological, and Nuclear (MCBRN) Defense Team. For more information on MCBRN, refer to Chapter XI.

g. Infectious Disease (ID) Team (UTC FFHA2). For more information, see Appendix D.

h. United States Air Force Prevention and Aerospace Medicine. For more information, see Appendix D.

i. Theater Epidemiology Team. For more information, see Appendix D.

j. Air Force Radiation Assessment Team (AFRAT). For more information, see Appendix D.

k. For more information on federal response assets, see FM 3-11.21/MCRP 3-37.2C/NTTP 3-11.24/AFTTP [I] 3-2.37.

**This page intentionally left blank.**

## Chapter XI

# INDIVIDUAL AND COLLECTIVE PROTECTION SYSTEMS

### 1. General

a. Most hospital sections operate in sheltered areas (tentage or hard-walled shelter) some protection is provided against vapor, liquid, and particulate (fallout) hazards. Sealing all openings can increase the temporary protection from such hazards; all entries and exits must be curtailed while operating in this mode. Liquid agents will eventually seep through the tent fabric and create a vapor hazard inside the shelter. Locating equipment, such as trucks, under trees or other cover provides similar effects.

b. Setting up MTFs in existing structures (concrete or steel buildings) provides greater protection from hazards and eliminates many decontamination problems. However, without means to seal openings, CW agent vapors can enter the structure. The addition of CB filtration systems with airlocks, that provide overpressure, can provide maximum protection for occupants. Entry and exit procedures must be established to prevent contamination being introduced by personnel and patients entering. Without CPS systems, hospitals may operate for a limited time in a nonpersistent agent environment, but are incapable of operating in a persistent agent environment.

(1) Chemical/biological filters for fixed-site hospital ventilation systems will be a critical item of supply. Controlled entry and exit points with sufficient space to permit placement of litter patients and/or numbers of personnel that permit purge of vapors will have to be established. All windows, doors, and other points that may have air leaks will have to be sealed (use tape and plastic sheeting) to enable the facility to have a positive overpressure to keep CB agents out.

(2) Liquid CW agents can penetrate the TEMPER in about 6 hours or GP tentage in a shorter period of time. These agents will penetrate the wrappings on medical supplies and equipment; especially, sterilized equipment and supplies, paper-wrapped cotton sponges, and open or lightly closed medications/solutions. They can also contaminate water/food supplies. Therefore, equipment and supplies must be stored in protected areas or under protective coverings.

(3) Without a CPS system, treatment procedures involving open wounds or the respiratory tract in the presence of a CB agent hazard is limited. Exposing open wounds and the respiratory tract to the agent increases the effects of these agents on the patient.

(4) Without hardened protection, the MTF, staff, and patients are susceptible to the effects (blast, thermal, radiation, and missileing) of nuclear weapons.

(5) Medical treatment facility electrical and electronic medical equipment is vulnerable to the effects of the EMP produced by nuclear weapons. The EMP is not harmful to humans, animals, or plants, but is very damaging to electronic equipment.

(6) Medical treatment facility equipment is very difficult to decontaminate. Aging (allowing the agent to off-gas) may be the only means of decontamination.

(7) Concealment and good OPSEC will help prevent identification of a unit.

c. Dispersion is a defensive measure employed by tactical commanders; however, hospital operations limit the value of this technique. One technique that may be used is locating sections of the hospital, such as the motor pool, personnel billets, laundry, and logistical storage a greater distance from the MTF complex than normal. This will increase dispersion without severely compromising the hospital mission.

d. The MOPP ensemble will not protect personnel from external gamma and neutron radiation exposure. It will, however, protect personnel from external alpha particles and all but the most energetic beta particles. Standard MOPP Level 4 affords excellent radiological contamination protection. Standard issue military protective masks (M-40 or equivalent) provide excellent protection from inhalation and ingestion of radioactive material.

## 2. Types of Collective Protection Systems

a. The CPS is a survivable, mobile shelter system, which includes both soft-wall and rigid-wall shelters. These systems are survivable against chemical, biological, radiological particles, and other threats. To continue the HSS mission under CBRN conditions, MTFs must search out contamination free areas or employ CPS systems. Roles 1 and 2 MTFs may be able to locate contamination free areas; however, due to the mobility limitations of hospitals, they must always be prepared to operate under CB conditions if the area is under attack.

b. The CBPS is a highly mobile vehicle-mounted rigid-wall shelter with an attached chemical and biologically protected airbeam supported tent. This provides an environmentally controlled work area that filters out nuclear, biological, and chemical agents. It will not protect personnel or patients from the thermal, blast, and initial radiation effects of nuclear weapons; however, it will provide some protection against fallout effects. The CBPS system is employed at the BAS, brigade support medical company (BSMC) Role 2 MTF, and FST. The CBPS is designed to be used at deployed Roles 1 and 2 MTFs. The CBPS (M1 System) is permanently integrated with a mobile dedicated platform and is attached to the hardwalled box on the rear of a high mobility multipurpose wheeled vehicle (HMMWV) (Figure XI-1).

(1) The BAS has one CBPS system per treatment team; the BSMC Role 2 MTF has four CBPS systems; while the FST has three CBPS systems. Systems can also be issued to other selected medical treatment teams. When employed at the BSMC, the patient holding team will require GP tents to hold their required number of patients.

(2) Patients held inside the CBPS are those that have been decontaminated and admitted into the system for treatment or are recovering from the treatment procedures and are awaiting evacuation.

(3) Any patients held in the GP tent must remain in MOPP Level 4 (the GP tent does not have collective protection); these patients are those that are expected to RTD within 72 hours.

---

Notes: 1. Normally, patients will not be held at the BSMC Role 2 MTF under CBRN conditions unless evacuation cannot be accomplished. They should be RTD or evacuated to a clean MTF as soon as the mission permits.

2. The CBPS can also be employed as the BSMC Role 2 MTF in the conventional mode. Employment in either mode still requires GP tentage for patient holding to meet total patient holding requirements.

---

c. The M20/M20A1 simplified collective protection equipment (SCPE) is another system that is available to provide collective protection to existing structures. It consists of a chemically protected room liner, a CB filter blower, and an ambulatory airlock. However, it does not have a litter airlock making it unsuitable for litter patient care. The M20/M20A1 may be used to protect medical staffs at the BSMC Role 2 MTF, FST, and hospitals, patients held in the GP tents at the BSMC Role 2 MTF and in the minimum care wards and

staff quarters of the hospitals. Thus, providing additional CB protection for staffs and patients.

d. The M28 collective protection equipment (CPE) is a highly transportable CPS used in conjunction with the TEMPER and the AMEDD Shelter System (A2S). The modular system consists of agent resistant liner sections, protective entrance (PE), tunnel airlock litter patient (TALP), hermetically sealed CBRN filter canister, recirculation filter, and a support kit containing a motorized blower and ancillary equipment. These components are available separately as spare parts or packaged together into six basic M28 CPE configurations. A "Type II" M28 CPE liner configuration, developed exclusively for the USAF, uses a slightly different liner interface design. The Type II liner components are currently available as spare parts only.

(1) In addition to the basic M28 CPE components are vestibule liners, which allow interconnection of liner systems to create a larger protective area. Used in combination with ISO adapters, vestibule liners allow the addition of ISO shelters to the protective area. Also available is the CPE supply airlock, which provides a capability to bring palletized supplies or large equipment into the protective area.

(2) Basic M28 CPE components, in combination with vestibule liners, ISO liner adapters, and the CPE supply airlock provide a variety of options for configuring shelter complexes. Two examples of such shelter complexes are the Army's CPDEPMEDS, CSH and the Air Force's CPAMEDS.

e. The Collectively Protected Small Shelter System (CPSSS) provides chemical and biological agent protection inside the shelter to create a *shirt-sleeve* environment unencumbered by the stresses of IPE. Its major components are—

- Field Deployable Environmental Control Units (FDECU).
- Four hundred cubic feet per minute (cfm) fan filter assemblies (FFA).
- Modified M28 CPE liner sections.
- Bump through door airlocks.
- Five hundred and eighty cfm FFA for the bump through door airlock.
- Two hundred cfm M98 gas particulate filter sets.

(1) The system is packaged into kits that are lighter in weight compared to other transportable CPS.

(2) The CPSSS when properly employed provides a toxic-free area in which personnel can conduct operations, maintain critical equipment, rest, eat, and sleep. The CPSSS can be complexed together to increase the capacity to suit operations. It is equipped with airlocks; decontaminated personnel move into the system without introducing contaminants. These systems are transportable and are compatible with 463L pallets. They are used near mission critical facilities to protect and provide rest and recuperation (R&R) for sortie generators and C2 for key leadership. The main user of this system is the USAF.

f. The CPS integrates into the medium Modular General Purpose Tent System (MGPTS) and provides a clean-air shelter for use against CW and BW agents and radioactive fallout.

(1) Its major components are—

- Modified M28 CPE protective liner and floor.
- Two hundred cfm hermetically sealed filter canister.

- M28 support kit (includes blower).
- Recirculation filter assembly.
- Accessory kit.
- Tunnel airlock litter patient.
- Integrated airlock.

(2) The main user for this system is the USMC and it provides chemical, biological and radioactive particle collective protection to operating forces in threat areas while deployed. The liner system—

- Can be fully operational in an uncontaminated environment in 30 minutes with four personnel.
- Provides (approximately) 240 square feet (sq ft) of floor space, occupying one-half of the MGPTS. Depending on mission requirements, one or two liner systems may be used.
- Is used as environment protection for rest and relief, C2, support or maintenance, and medical.
- Has a flexible configuration.
- Can accommodate external ECUs.

g. The shipboard CPS Backfit Program was created to provide additional collective protection capabilities to existing amphibious class ships allowing personnel to perform mission critical operations in a CBRN environment.

(1) Its major components are—

- M98 Gas-particulate filter sets.
- Pre-filter bags and filter housings.
- Van-axial fans.
- Fan rooms.
- Airlocks.
- Pressure gauges.
- Zone pressure relief valves.
- Zone alarms and control panels.
- Contamination station.

(2) The program installs additional CPS toxic free zones in critical areas including medical, C2, R&R, and casualty collecting areas. Personnel working in these protected areas do not have to wear IPE during or after a CBRN attack. The CPS allows additional toxic free zones that allow the ship's personnel to operate in a chemical, biological, and radiological environment. The CPS has a 3 plus year filter life. The LHA/LHD class ships are now capable of receiving and treating contaminated casualties in a collectively protected environment. The main user of this system is the USN.

### **3. Collectively Protected Field Hospital**

a. Chemically Protected-Deployable Medical System.

(1) Deployable Medical Systems (DEPMEDS) was developed in the 1980s to standardize a hospitalization system. The DEPMEDS hospitals are assembled from standard functional modules. These modules are housed in rigid aluminum ISO-standard shelters, including radiology, laboratory, pharmacy, central materiel services rooms, and operating rooms. Some of the auxiliary functions are housed in vans as well as TEMPER and A2S units.

(2) The CPDEPMEDS is a containerized set and a complex of TEMPER tents, passageways and expandable shelters that provides Army DEPMEDS-equipped CSH with the capability to sustain operations in a CBRN environment. The result will be a functional barrier against harmful warfare agents or fallout that allows the hospital to treat casualties without the use of protective gear or causing further harm.

(3) The DEPMEDS-equipped patient care areas of the US Army Medical Reengineering Initiative (MRI) CSH will employ the CPDEPMEDS. It will not protect personnel or patients from the thermal, blast, and initial radiation effects of nuclear weapons; however, it will provide some protection against fallout effects. The system includes—

- Chemically/biologically protected liners for TEMPER and passageways.
- CB-filtered and conditioned (heated or cooled) air via FDECU or H80 Army standard heater).
- Chemically/biologically protected ambulatory, litter, and supply airlocks.
- Chemically/biologically protected latrines.
- Chemically/biologically protected seals for ISO shelters.
- Chemically/biologically protected water supply system.

(4) In the MRI configuration, CPDEPMEDS can be issued and deployed in an 44-bed configuration early entry hospital element which consists of equipment in three 20-foot (ft) MILVANs, one 100 kilowatt (kW) generator, and one 3-in-1 expandable ISO shelter (containerized latrine).

(5) The 44-bed hospital can grow to an 84-bed hospital with a 40-bed augmentation kit, which consists of equipment in one 20-ft MILVAN and one 100 kW generator. The 44-bed and 40-bed augmentation use the A2S tentage.

(6) The CPDEPMEDS can also be issued and deployed in an independent 164-bed configuration which consists of equipment in six 20-ft MILVANs, two 100 kW generators, and one 3-in-1 expandable ISO shelter (containerized latrine). The 164-bed configuration uses TEMPER tentage.

(7) The 44-bed hospital, 40-bed augmentation, and the 164-bed hospital can be combined into one 248-bed hospital. There are a number of recommended layouts, but it is up to the commander to determine the final hospital layout.

(8) For the Medical Force 2000 (MF2K) version of CPDEPMEDS, only 236 beds of a 296-bed hospital are protected. In the MRI configuration, equipment is provided to protect all beds in each hospital size. The CPDEPMEDS program is in the process of converting MF2K CPDEPMEDS to the MRI configuration. When the conversion is complete, a total of twelve 248-bed CPDEPMEDS will be available in the War Reserve.

b. The Collectively Protected Expeditionary Medical Support.

(1) The CPEMEDS provides an air-transportable medical facility that allows the medical personnel and patients to work without individual chemical and biological protective gear. The CPEMEDS uses the CPSSS with the associated CPE to chemically and biologically “harden” the shelter. The components are kitted by increment ranging from a single 32-foot collectively protected small portable expeditionary aeromedical rapid response (CPSPEAR) to a ten 32-foot shelter 25-bed hospital complex (CPEMEDS +25). See AFTTP 3-42.71 for details regarding EMEDS increments and capabilities.

(2) The CPEMEDS can be supplemented based on mission needs with collective protection hospital surgical expansion package (CPHSEP) and collective protection hospital

medical expansion package (CPHMEP). The CPHSEP adds a 32-foot soft-sided shelter and a hard sided ISO shelter, tactical, expandable, two sided. These additions increase the toxic-free surgical capability. The CPHMEP adds four soft-sided shelters, which increases the toxic-free inpatient ward space to three shelters with an additional shelter for postoperative patients.

(3) The CPEMEDS uses the FDECU (1 per tent) or in some cases substitutes the Lightweight Environmental Control Unit for the FDECU. One FFA (400 cfm) is used per tent and one FFA (580 cfm) is used for the bump through door airlock. The 200 cfm M98 gas particulate filter sets are used in all the applications.

(4) The CPEMEDS +25 has the capability to provide 24-hour sick call, 25 inpatient beds, and emergency medical care to a population at risk of 5,000–6,500. The CPEMEDS provides a contamination free environment where medical treatment can be rendered to personnel without the encumbrance of IPE.

(5) When the threat of CBRN action is anticipated in the AO, the CPEMEDS components must be set up as the EMEDS is being established. The system cannot be set up in a hospital that has already been established. The collective protection liners must be installed during the EMEDS erection process. To establish CPS in an EMEDS-equipped hospital, follow the procedures as described in the Operation and Maintenance Manual for CPEMEDS. Copies can be downloaded from the ACC/SG-Manpower and Equipment Force Packaging (MEFPAK) Web site at <https://afkm.wpafb.af.mil/DocTax/Entry.aspx?Filter=MD-SG-00-15> under the category “Collective Protection.”

c. The Collective Protection Expeditionary Medical Facility (EMF).

The CPEMF will integrate environmentally controlled collective protection into the Navy’s EMF fleet hospital configuration. Fleet hospitals are first and foremost land-based hospitals, medically and surgically intensive. They are transportable and designed for sustained operations of 60 days or greater and are deployable in a variety of operational scenarios. The fleet hospital can be mobilized in two primary formations: a 500-bed hospital or a 20- to 116-bed EMF. The EMF maybe utilizing a new style of deployable medical unit, the BASE-X Expedition Shelter and will require the integration of the M28 CPE.

#### **4. The Joint Expeditionary Collective Protection Program**

a. The JECP program is an ACAT III, Joint Service program with participation by the Army, Air Force, Navy, and Marines. The JECP provides the warfighter with percutaneous, respiratory, and ocular protection from CB warfare agents, radiological particles, and selected TIMs. The JECP will be the next generation lightweight, modular, easily transportable, self-supporting CPS that will provide relief from psychological and physiological stresses during sustained operations in a contaminated environment. The Joint expeditionary forces are required to be prepared to operate on the sea, littoral, land, and in the air, often for extended periods in austere, expeditionary, and possibly chemical, biological, and radiological/TIM contaminated environments.

b. The JECP is intended to collectively protect expeditionary forces by providing a versatile, transportable, capability to convert common structures and tentage into a collectively protected space or establish a stand-alone collective protection shelter. This capability will be adapted in remote locations and harsh environments where sustainment/support is challenging and fixed-site collective protection is limited or nonexistent.



c. The JECF will support common, overlapping functions associated with operational activities, such as electrical power, sanitation, eating-drinking, cooling-heating, floor space, entry/exit, and contamination control. The JECF will provide flexibility by reducing the need to deploy, move, and maintain large, heavy, and complex collective protection systems. When employed in a C2 scenario, JECF will allow C2 to continue without degradation. When employed in an R&R scenario, JECF will provide R&R for both personnel required to wear IPE and MWDs. It will allow personnel to remain unencumbered while eating, drinking, sleeping, and attending to bodily functions. When employed in the medical scenario, JECF will provide a toxic-free environment for receiving, treating, and holding human and MWD casualties. For protection of critical equipment scenarios, JECF will provide a toxic free environment allowing personnel performing sensitive operations to work unencumbered by IPE.

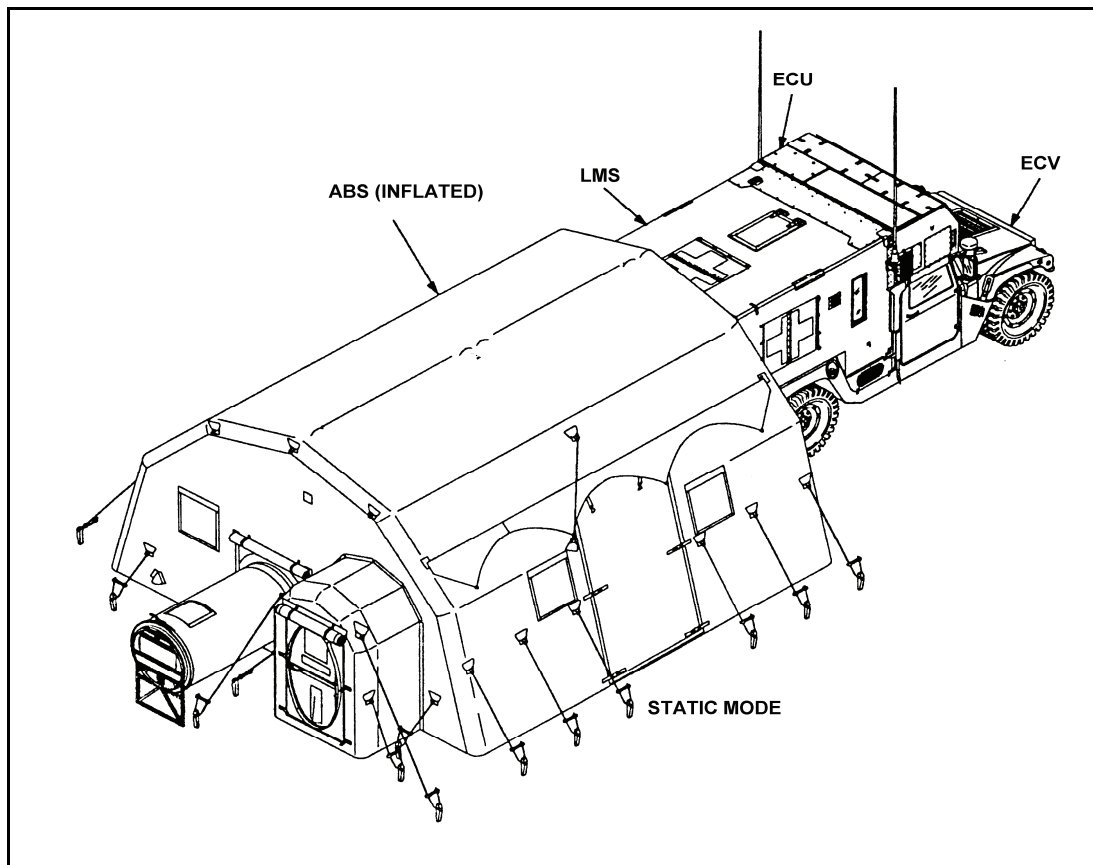

**Figure XI-1. Chemical Biological Protective Shelter System**

## **5. Employment of the Chemical Biological Protective Shelter System**

a. Establish a Role 1 MTF/BAS in a CBPS. One CBPS per treatment team in a Role 1 MTF/BAS is used for conventional operations in a split-team mode. When operating in a squad configuration and in the conventional mode, two CBPS systems may be complexed to provide more workspace. However, the treatment squad is not staffed to operate the two systems in the CB mode.

b. When the two systems are not complexed, the treatment squad must operate in the CB mode and must use only one system. Although each treatment team of the BAS has a

CBPS; only one system is set up when operating in the CB mode. This is due to the lack of authorized personnel to operate all systems at one time in the CB mode. Eight medical personnel are required to operate the BAS (employing one CBPS) in the CB mode. At least eight nonmedical personnel are required to perform patient decontamination under medical supervision.

c. By setting up one system in the CB mode, it provides the BAS the ability to retain its flexibility in order to maintain its support mission of being where it is needed and when it is needed. The CBPS can be used as the treatment shelter in the conventional mode as well. When the treatment squad is operating in the split-team mode, each team will have a CBPS for use as its treatment shelter. When operating one system in the CB mode, the other system provides a replacement in the event it is damaged beyond repair. This ensures continued HSS to the command.

d. When setting up the PDS, the contaminated ambulance point, contaminated triage point, patient decontamination area, and contaminated treatment area is established on the downwind (prevailing wind) side of the CBPS. An overhead cover of plastic sheeting (approximately 20-ft wide by 50-ft long) is set up over the PDS, the hot line, and the clean treatment/waiting area. The cover must overlap the airlocks. The clean treatment/waiting area should have an area at least 20-ft wide by 15-ft long to allow space for placing patients into the litter airlock without crossing the hot line.

e. A second area covered with 20-ft by 25-ft of plastic sheeting (the evacuation holding area) is set up beside the shelter on the opposite side from the generator. The clean treatment area is separated from the decontamination area by a hot line with a shuffle pit. Only clean (decontaminated) patients or personnel are allowed to cross the hot line into the clean treatment area or are admitted into the CBPS. Each CBPS provides a minimum of 300 sq ft of work area. Figure XI-2 presents one layout of a BAS using the CBPS. See TM 10-5410-228-10 for complete details on setting up, operating, and maintaining the CBPS.

---

Note: The overhead cover is not needed when the wind speed exceeds 10 knots per hour. The plastic will not stay in place.

---

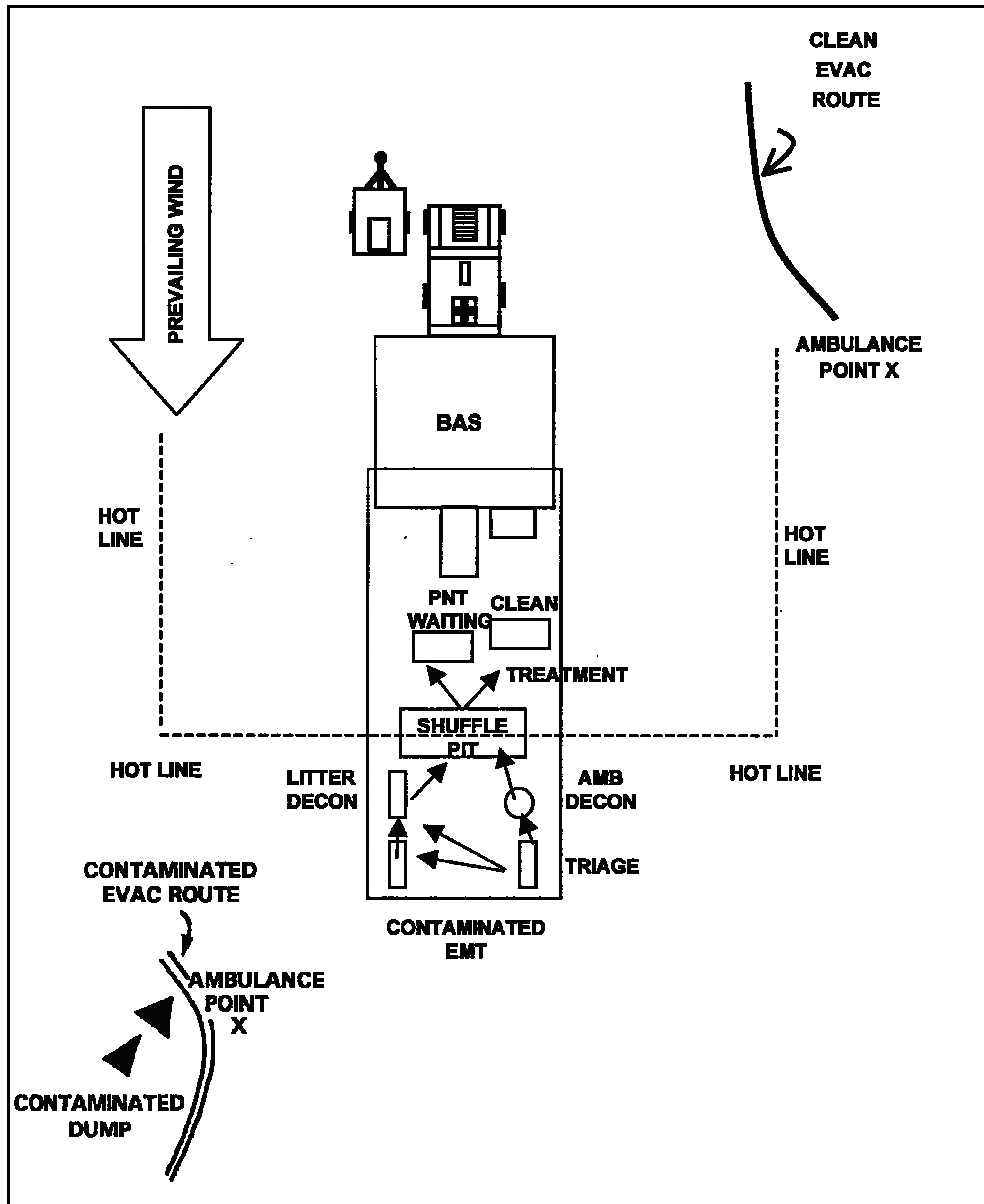

Figure XI-2. Battalion Aid Station Using the Chemical Biological Protective Shelter

## 6. Brigade Support Medical Company Role 2 Medical Treatment Facility in a Chemical Biological Protective Shelter

a. To establish a BSMC Role 2 MTF using the CBPS, four shelters are set up. The four shelters are complexed as shown in Figure XI-3. With four CBPS systems set up and operational, a total of 1,200 sq ft of work area is available. The contaminated triage, decontamination, and contaminated treatment areas are separated from the clean treatment/waiting area by a hot line with a shuffle pit. Overhead covering is provided as described for the BAS. Patients are admitted through the EMT litter or ambulatory airlock. Patients are released through the patient holding airlocks. This aids in controlling entry and exits; thus preventing the introduction of contamination into the systems. At least eight

nonmedical augmentation personnel from supported units are required to perform patient decontamination under medical supervision at the BSMC Role 2 MTF.

b. In the event that the overpressure system fails on a system that is in use with entry/exit airlocks, move to the available shelter with an entry/exit airlock in the same direction for use as the entry/exit until the failed system can be restored.

- Example 1: At the BAS Role 1 MTF, if the EMT system fails, move to the ATM shelter to receive patients until the EMT system has been restored.
- Example 2: At the BSMC Role 2 MTF, if the patient hold system fails, move exits to the dental/laboratory/x-ray shelter until the patient hold system can be restored.
- Example 3: At the FST, if the postoperative system fails, use the preoperative shelter until the postoperative system can be restored. These options will allow patient care operations to continue until the failed system can be restored.

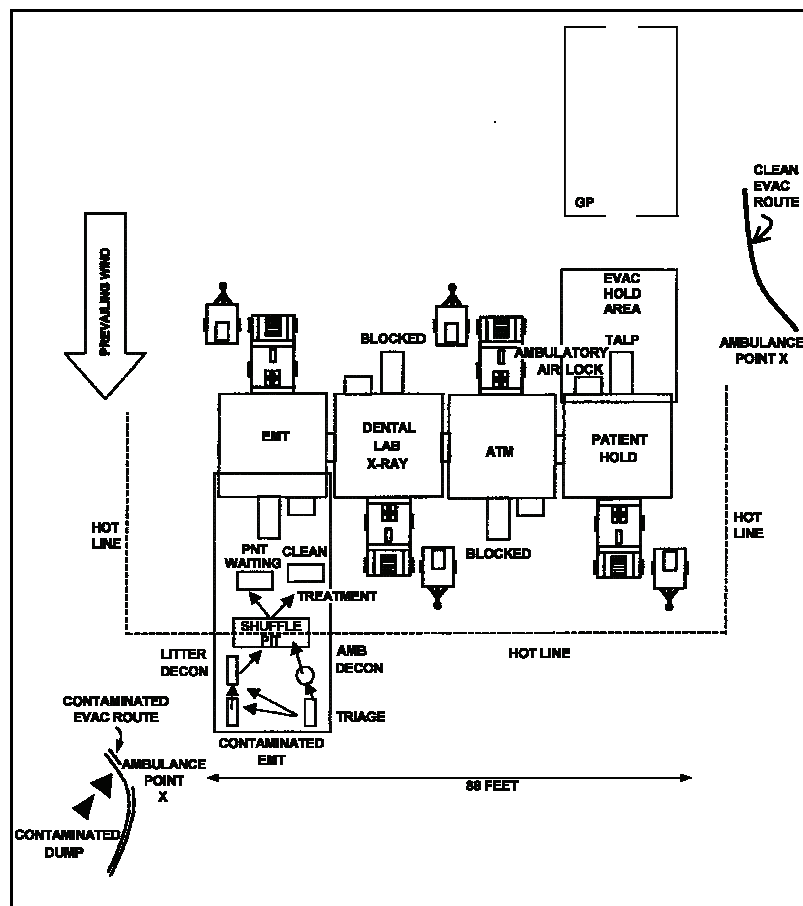

**Figure XI-3. Chemical Biological Protective Shelter Configuration as a Brigade Support Medical Company Role 2 Medical Treatment Facility**

## 7. Forward Surgical Team in a Chemical Biological Protective Shelter

a. To establish an FST using the CBPS system, follow the procedures for the BSMC Role 2 MTF except only three CBPS systems are set up. With three CBPS systems set up and operational, a total of 900 sq ft of work area is available (Figure XI-4). When the FST is located forward in support of a medical company and operating in the CB mode, the FST

systems are connected to the Role 2 MTF of the supported BSMC. Figure XI-5 shows the FST and BSMC Role 2 MTF connected.

b. When operating in the CB mode with the BSMC, all patients are received through the EMT airlock of the BSMC Role 2 MTF. The patients are triaged in the BSMC Role 2 MTF and, based upon their injuries, they are routed to the treatment area of the Role 2 MTF or to the FST for surgical care. Patients released from the FST for evacuation are placed in a PPW and processed through the litter airlock in the FST recovery section. Patient decontamination is performed at the PDS operated by the BSMC Role 2 MTF. The FST cannot operate in a CB environment without being complexed with the BSMC Role 2 MTF. They do not have any patient decontamination capabilities.

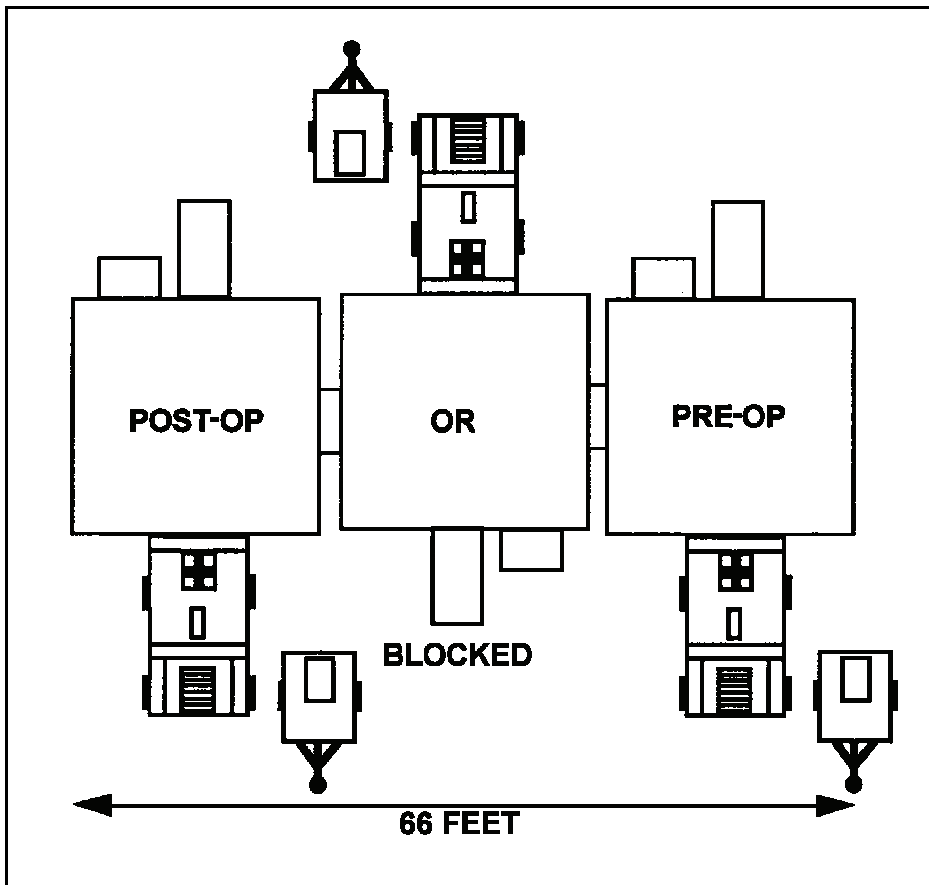

Figure XI-4. Forward Surgical Team Configuration for Operations in Conventional Mode

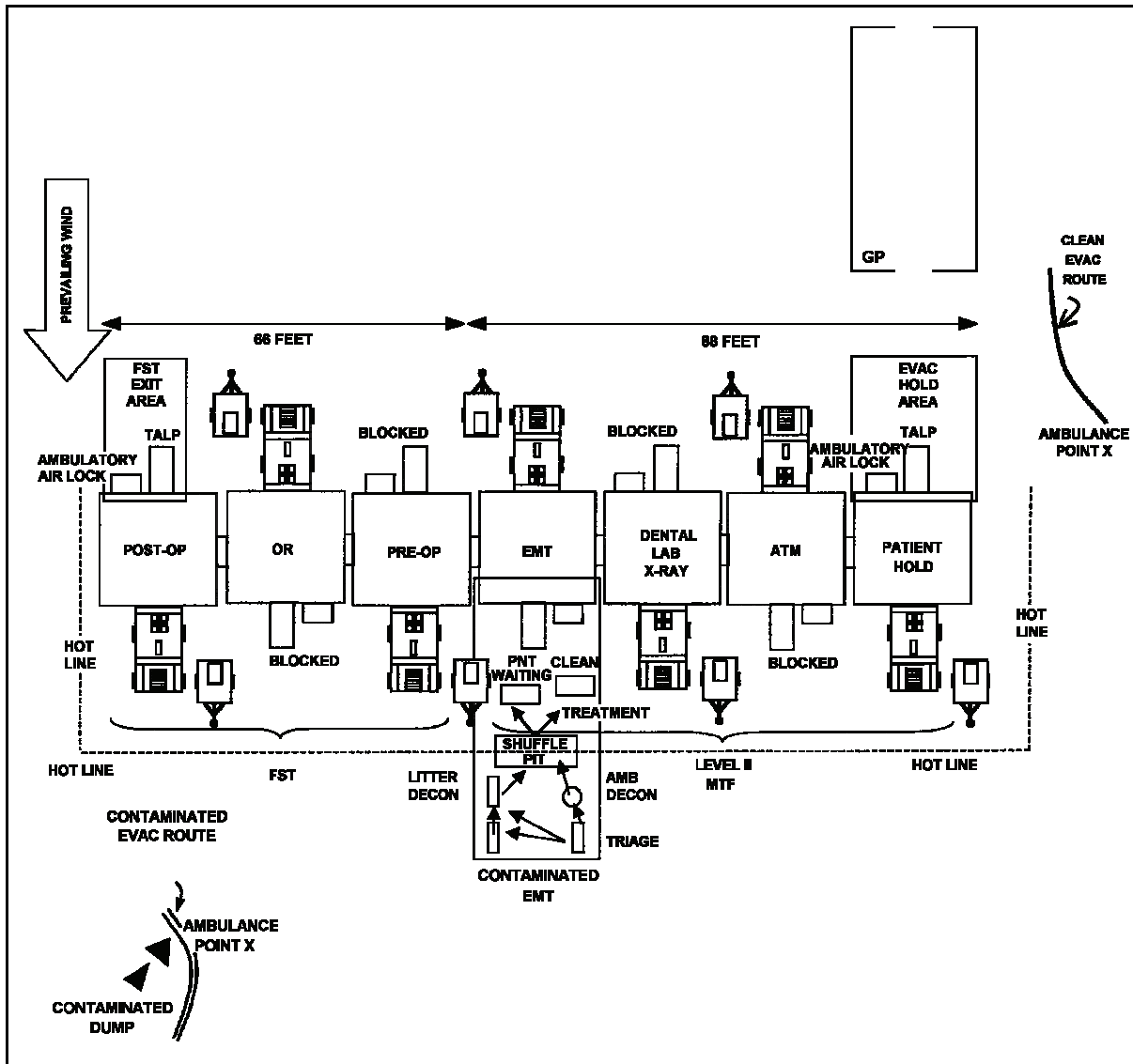

Figure XI-5. Forward Surgical Team and Brigade Support Medical Company Role 2 Medical Treatment Facility Configuration for Operations in a Chemical, Biological, Radiological, and Nuclear Environment

## 8. Employment of the Chemically Protected Deployable Medical Systems and Simplified Collective Protection Systems

a. When the threat of CBRN action is anticipated in the AO, the CPDEPMEDS components must be set up as the CSH is being established. The system cannot be set up in a hospital that has already been established. The M28 liners must be installed during the CPDEPMEDS erection process. To establish CPS in a DEPMEDS-equipped hospital, follow the procedures as described in TM 10-5410-283-14&P. Figure XI-6 presents one layout of the DEPMEDS-equipped patient care area of a MF2K CSH hospital unit base employing the CPDEPMEDS with an internal water supply system. Figure XI-7 presents a layout of the patient care area of the DEPMEDS-equipped portion of an 84-bed MRI hospital. Figure XI-8 presents a layout of the patient care area of the DEPMEDS-equipped portion of a 164-bed MRI hospital.

b. When employing CPDEPMEDS, provisions for waste disposal and protected water and food supplies within the system are established. Additionally, Class VIII supplies must be protected from contamination. Supplies not in use or needed in the protected operational areas are stored in medical chests, shipping containers, or wrapped in layers of plastic that are inside covered areas, such as closed MILVANS or tents.

c. When contamination is present, only open these storage areas for operational area emergency resupply. Use plastic sheeting or other leak-proof material to provide an additional barrier between the supplies and the contamination. Wrap supplies in plastic or other barrier material for movement from the storage area to the resupply airlock of the CPDEPMEDS.

d. A water supply system with distribution hoses is established inside the CPDEPMEDS areas (Figure XI-6). Pumps continuously circulate the water from the storage tank through the hose system back to the storage tank. The continuous circulation ensures that the chlorine residual is maintained in the water supply. Personnel in areas that are not included in the continuous flow system must draw water from the system and carry it to their work areas in 5-gallon water cans or other containers. Water resupply is accomplished by passing a hose through the utility port at the end of the TEMPER and M28 liner for connection to the water transport vehicle. The ends of both hoses must be decontaminated with a 5 percent chlorine solution before connecting them together. The vehicle must have a tank or water supply container that is CBRN protected to ensure that the water supplied is free of CBRN contamination.

e. Rations, as determined by the hospital commander, should be available within the protected area for personnel and patients. Under emergency conditions the commander can authorize feeding patients MRE rations for limited periods of time (up to 72 hours), if they are able to chew and swallow. However, attempts must be made to ensure the required types of rations for patient feeding are available in the CPS. The rations can be stored in any available space; however, the rations must be protected from exposure to possible contaminants, especially liquids. Ration control measures are established to ensure that the rations are only consumed as provided for in the hospital TSOP.

f. Two CB protected latrine systems are included in the CPDEPMEDS. The latrines contain bedpan wash areas. The waste from the latrines is collected in an outside receiving container.

g. Solid waste (including medical) must be placed in plastic bags. Seal the top of the bags to prevent spillage, odors, or spread of infections/disease. Never overfill the bags; always leave enough room in the bag to make a good seal. Place the sealed bags in the supply airlock. Inside personnel ensure that the inner door to the airlock is closed. Outside personnel check to ensure that the inner airlock door is closed before opening the outside door. Remove the bags and take them to the designated waste collection/disposal site. Disposal may be by burial on site or by transport to a designated disposal facility.

h. All liquid waste produced within the CPDEPMEDS is collected through a piped liquid waste system to a central collection container. The waste container for the latrines may be used to collect the liquid waste from the operational areas of the CPDEPMEDS.

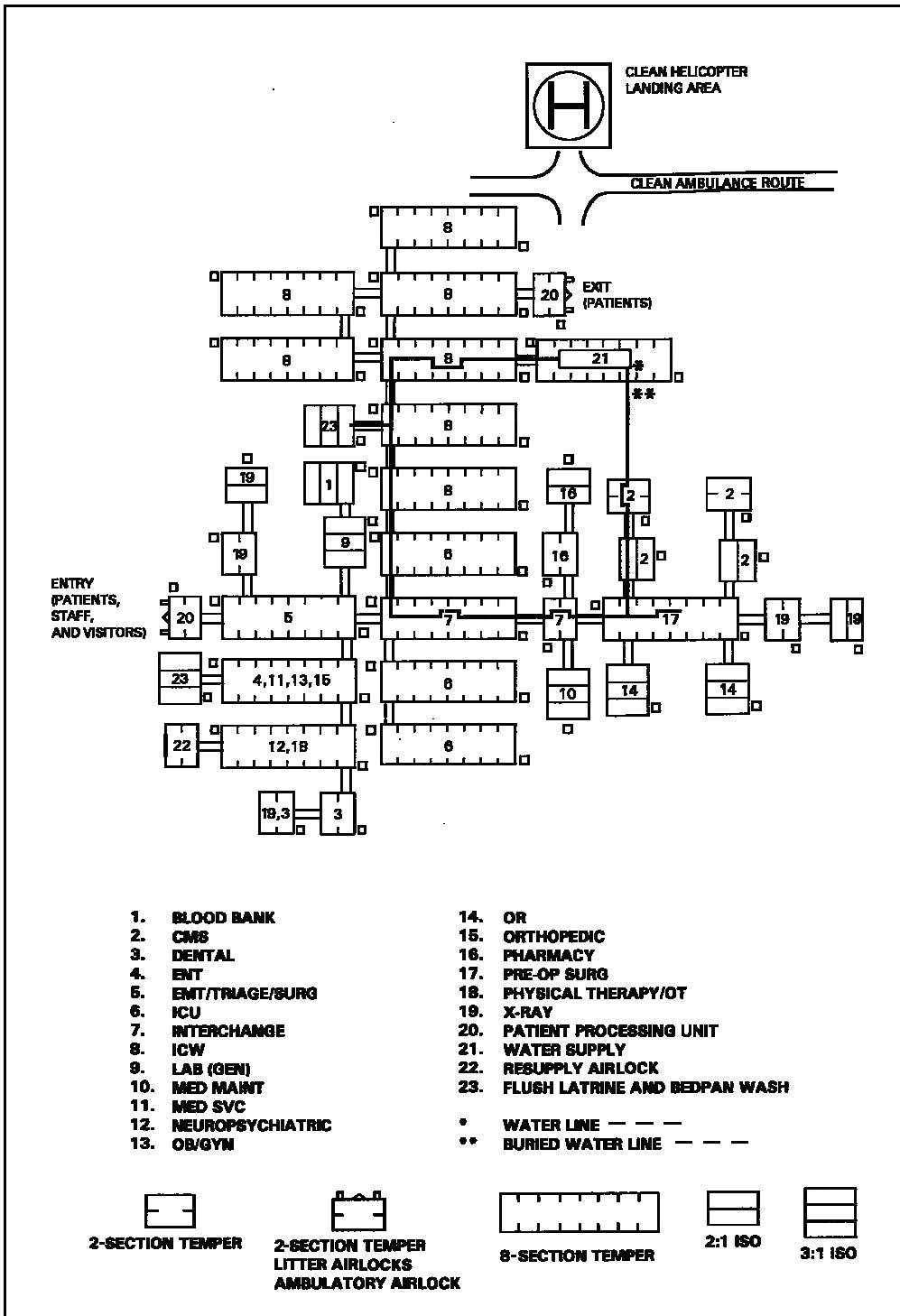

\* Internal Water Distribution System  
 \*\* Trenched And Buried Line

**Figure XI-6. Sample Layout of a Medical Force 2000 Combat Support Hospital (Unit Base) Employing Chemically Protected Deployable Medical System**



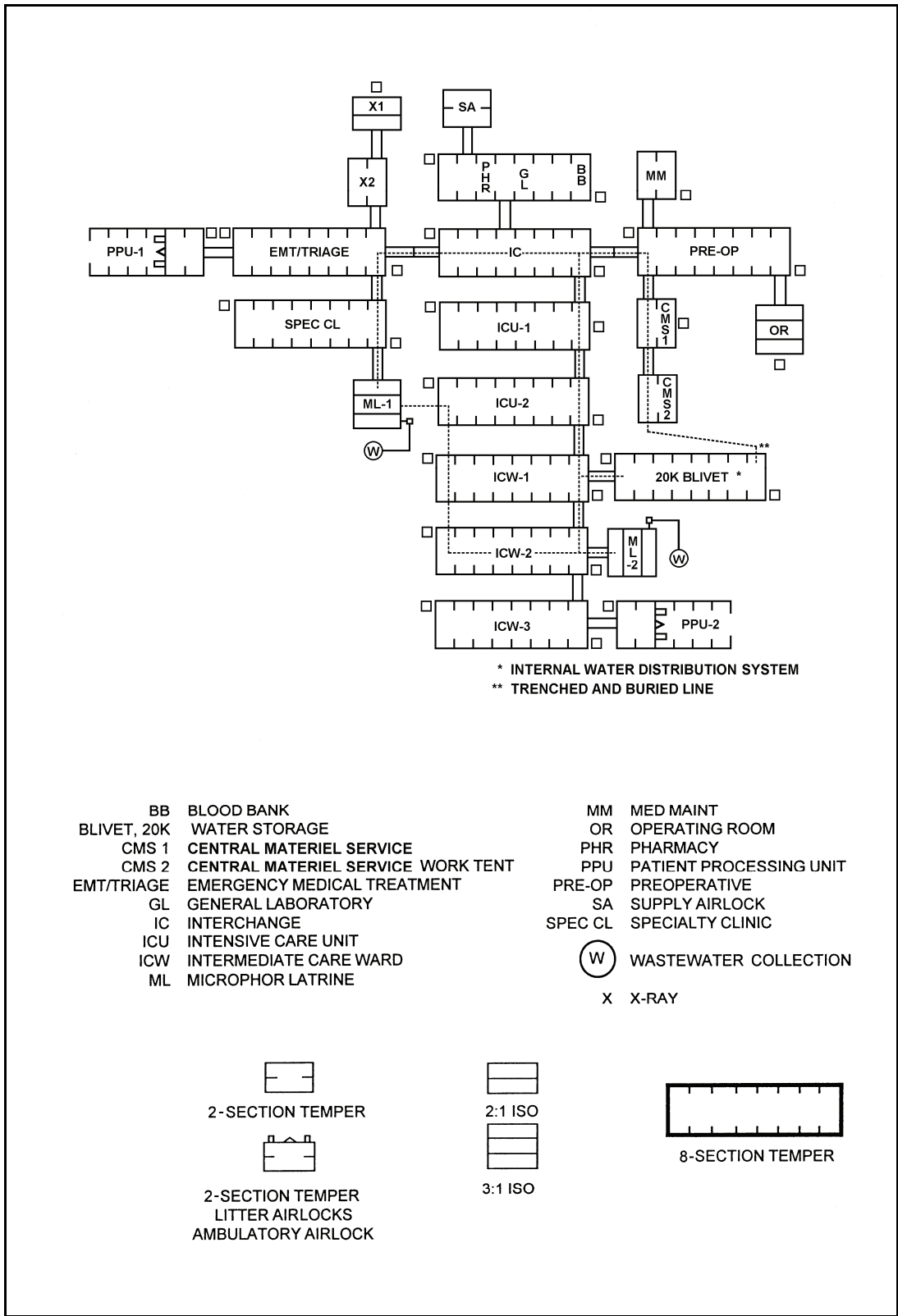

**Figure XI-7. Sample Layout of an 84-Bed Medical Reengineering Initiative Hospital Employing Chemically Protected Deployable Medical System**

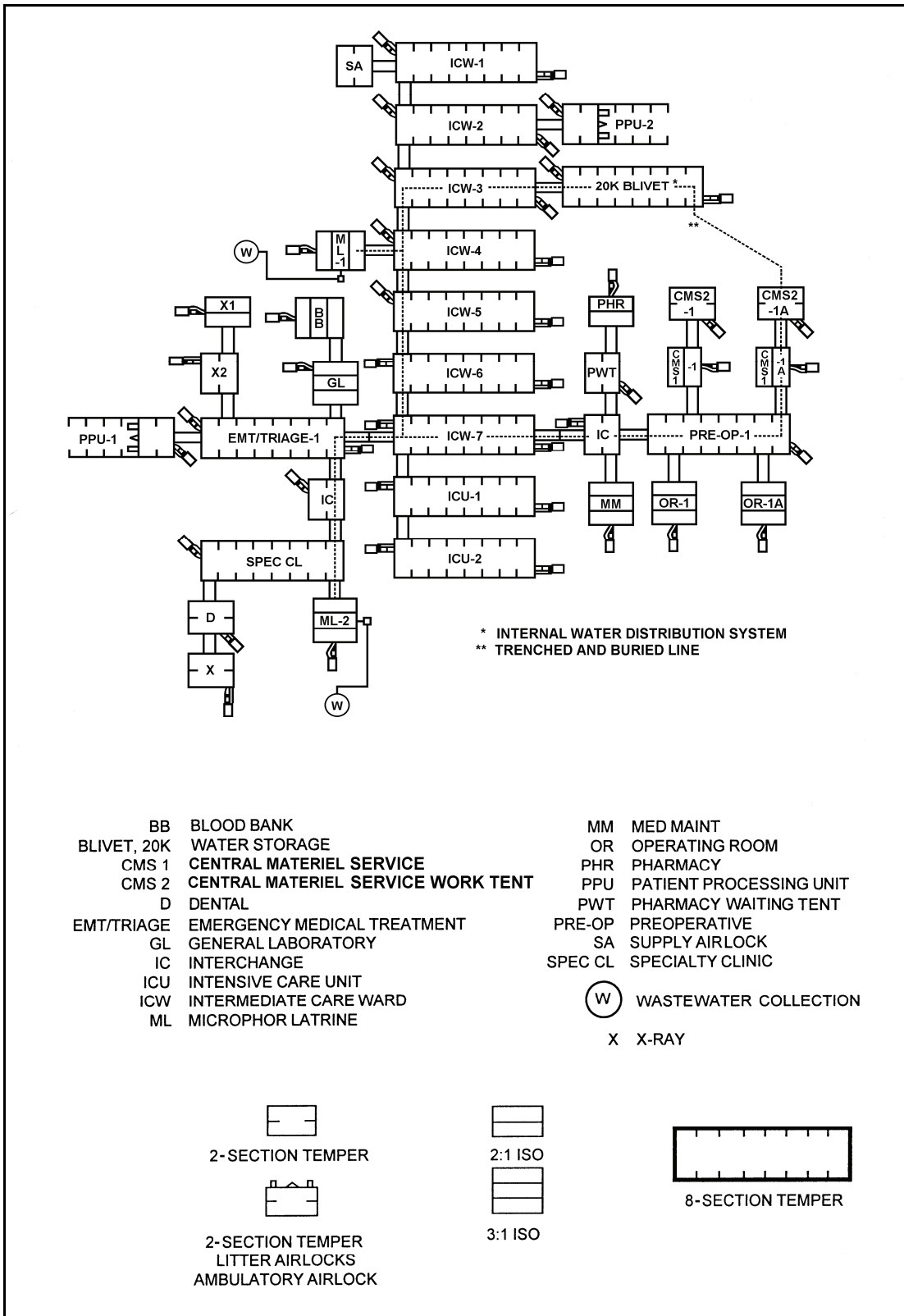

Figure XI-8. Sample Layout of a 164-Bed Medical Reengineering Hospital Employing Chemically Protected Deployable Medical System

## **9. Chemically/Biologically Protecting the International Organization for Standardization Shelter**

To chemically/biologically protect the ISO shelters, seal all seams and openings of the ISO to prevent the entry of CB agents. The seals connecting the various sides and floor of the shelter must be of CB protected material; thus providing a seal to the shelter. When the seals are not of a CB protected material, the seams must be taped to provide a CB protected barrier over the soft seals. Any openings not being used for introduction of support power lines, water lines or wastewater lines must be sealed to prevent entry of CB agents. All access panels must be securely closed to prevent entry of vapors.

## **10. Chemically/Biologically Protecting the Vestibules**

The vestibules connect TEMPERs to TEMPERs, ISOs to ISOs, and ISOs and TEMPERs. To harden the vestibules, install the CB liners inside and fasten the ends to the liners of the TEMPER or to the doors of the ISOs. Vestibule liner connectors are provided for use at the entry of each ISO.

## **11. Chemically/Biologically Protecting Air Handler Equipment**

a. The FDECU is a chemically/biologically protected ECU. It is a heat pump (reversing mechanical refrigeration system) intended for use in cooling, heating, dehumidifying, filtering, and circulating air for portable shelters, tents, and vans in order to satisfy equipment and personnel climate control requirements. The system can be operated without the CB filters. When required to operate in the CB mode, the fresh air intake on the FDECU is closed and the CB filter blower is turned on drawing fresh air through the filters to support the FDECU and to provide clean air for the CPS. Additionally, recirculation filters are placed within the shelter system to remove any agent that may have entered through any of the entry/exit areas or through breaches in the shelter system.

b. When heaters are required, they must be chemically/biologically protected to prevent entry of contamination. The CB filter units are connected to the fresh air intake side of the heater and the heated air discharge side of the heater is connected to the air supply of the TEMPER/ISO. For more information on FDECU, refer to Army TM 9-4120-411-14/Air Force Technical Manual (Technical Order) 35E9-314-1.

## **12. Establish Collective Protection Shelter Using the M20 Simplified Collective Protection System**

a. The M20 SCPE is used to establish a CPS within a room of opportunity or inside a tent; however, the available space will be limited by tent poles and other components of the tent. Currently, this system only provides ambient temperature air.

b. The SCPE provides a clean-air shelter for use against chemical and BW agents and radioactive particles. It is lightweight and mobile and it allows unit commanders to convert existing structures into protected working or rest area. The SCPE can be used as a temporary rest and relief shelter (for example, as a break area for medical personnel) or as a C2 center. It provides a contamination-free environment in which 10 Service members can work, eat, or rest without wearing an IPE. The M20 can be erected without the liner using only the PE and blower compartment. Places such as a bank vault or warehouse freezer are examples of where an M20 without liner can be placed. Any cracks or holes will need to be sealed in the doorway. A bib section is available that will fit between the PE and the frame of any door, and when taped down, seals the entrance from outside

contamination. Entry and exit restrictions remain the same. For guidance on maintenance and parts of the SCPE see TM 3-4240-288-12&P/NAVFAC P-475. The M20 does not have a litter airlock. Only staff or ambulatory patients can enter.

### **13. Patient Decontamination**

Patients admitted into the MTF must be free of contamination. Therefore, a casualty decontamination area must be established near the MTF. The casualty decontamination area should be provided with an overhead cover as described for the CBPS system, except that it does not overlap the entry to the hospital. Also, consideration must be given to the location of other operations at the hospital site when establishing the casualty decontamination area. However, the area must be close enough to the entry/exit of the CPS to protect the patients from the environment and reduce their exposure to recontamination. The entry/exit area must have overhead cover to protect patients awaiting access to the CPS. See Chapter V for setting up a patient decontamination area and for decontamination procedures.

### **14. Operations, Entry, and Exit Guidelines**

The following are the operations, entry, and exit guidelines to prepare a unit SOP for the operation of CPS systems. When using these guidelines, the following should be considered:

- Location of the shelter (flat, hilly, or rocky ground).
- General climate of the AO (high and low temperature variations during operation).
- Information on setting up, striking, and operating the CPS is contained in the equipment publications.
- Where applicable, special procedures are provided in these publications for setting up in both clean and CB vapor hazard areas. The CPDEPMEDS is not set up in a CB vapor hazard area. The commander will determine which procedures to use.
- During operations, periodic checks are made of the atmosphere within the shelter. These checks are made by using available chemical agent detection equipment and material to determine if chemical agent penetration has occurred. Should chemical agent penetration occur, all personnel must mask; then ensure that patients are protected until the agent has been purged from the shelter.

### **15. Decontamination of Entrance Area**

a. Normally, the MTF will not operate in a CB vapor hazard environment. However, if the MTF must remain in an area on a temporary basis and liquid agent contamination is present, the immediate area around the entrance must be decontaminated. To decontaminate the area around the entrance, use one or more of the following methods:

- Turn over about 2 inches of soil.
- Remove the top 1-inch layer of soil containing the liquid agent. Use the CAM/ICAM or M8 detector paper to check the area after the topsoil is removed to ensure complete agent removal.
- Add several inches of clean soil or sand.
- Mix STB into the top 1/2 to 1 inch of soil.
- Use decontamination solution 2 (DS2) on contaminated hard-surfaced areas or frozen ground.

b. All personnel (staff and patients) must be decontaminated before they are permitted entry into the CPS. Use chemical detection equipment to check for the presence of contamination on individuals and their equipment; also check for presence of contamination on individual weapons if they are allowed in the CPS. Normally, weapons will not be allowed in the patient care areas, but will be stored outside near the entry/exit point. Thorough decontamination is critical in preventing contamination transfer into the CPS.

c. When a chemical agent is detected, follow the procedures in Chapter V for patient decontamination and FM 3-11.5/MCWP 3-37.3/NTTP 3-11.26/AFTTP(I) 3-2.60 for other personnel and equipment decontamination before entering the CPS. All contaminated clothing and equipment are placed in the contaminated dump. If weapons are evacuated with the patient, they are decontaminated and held by the MTF (administrative personnel or hospital supply) for disposition instructions.

d. Decontamination must be thorough; procedures must be strictly followed. Failure to do so can contaminate the interior of the MTF and injure medical treatment personnel; thus reducing their mission support capabilities.

### **WARNINGS**

- 1. Always purge the airlock before opening the inner door, if the outer door has been opened.**
- 2. When operating in a toxic environment, never open the outer and inner doors of the airlocks at the same time.**

## **16. Entry/Exit for the Collective Protection Shelter System**

a. Ambulatory Personnel.

(1) Entry procedures.

(a) Ambulatory patients and others remove their MOPP (except their mask), BDUs/ACUs, and boots outside the airlock/personnel processing unit. This procedure reduces the amount of possible contamination entering the airlock.

(b) A check is made to ensure that the ambulatory airlock/personnel processing unit is empty and the inner door is closed.

(c) The individual enters the airlock/personnel processing unit and closes the outer door.

(d) The airlock/personnel processing unit is purged for 3 minutes. At the end of the purge cycle, the individual checks for contamination. If contaminated, the individual must return to the outside and decontaminate his skin; then return to the airlock/personnel processing unit and repeat the purge cycle and contamination check. If no contamination is detected, the individual removes the protective mask and then removes the filter from the mask. The filter is then disposed of in the designated contaminated trash bag. The protective mask is placed in a separate clean plastic bag. The plastic bag is sealed and labeled. The individual opens the inner airlock/personnel processing unit door and enters the CPS; the plastic bag is carried into the shelter with the individual.

(2) Exit procedures.

(a) A check is made to ensure that the ambulatory airlock/personnel processing unit is empty and the outer door is closed.

(b) The individual enters the airlock/personnel processing unit and closes the inner door.

(c) The individual puts on his protective mask; then exits through the outer door.

(d) The individual puts on his BDU/ACU and boots then assumes the established MOPP level before departing the immediate area of the exit door.

**WARNING**

**Do not open the outer door until after donning the protective mask.**

---

Notes: 1. If ambulatory patients that enter the collective protection shelter system become litter patients, they must be placed in PPW when released since the MTF does not have replacement MOPP ensembles for patient issue.

2. Exits between patients must be spaced so that at least a 3 minute purge of the airlock/personnel processing unit is accomplished before the inside door is opened. Only open the doors long enough to permit passage.

---

b. Litter Patients Entry Procedures. These procedures also apply when using the Tunnel Airlock Litter Patient.

(1) An outside medical personnel notifies an inside medical personnel that a litter patient is ready for admission.

(2) The inside medical personnel ensure that the inner litter airlock door is closed. The outside medical personnel open the outer airlock door and place the litter on the litter rails/stands when using the TALP or on the floor; the patient is pushed into the airlock headfirst; then the outer door is closed. After a purge time of 3 minutes, medical personnel inside the CPS opens the inner door to ensure that the patient is free of contamination. The patient is checked by placing the CAM/ICAM nozzle/M8 near absorptive surfaces, such as the patient's hair. If no contamination is detected, the medical personnel remove the patient's protective mask and then remove the filter from the mask. The filter is then disposed of in the designated contaminated trash bag. The protective mask is placed in a separate clean plastic bag. The plastic bag is sealed and labeled and placed in between the patient's legs or, when using the TALP, beside the patient's head or on the litter where it is accessible to the patient. The inside medical personnel removes the patient from the airlock and position him on treatment litter stands, or moves him to the treatment area.

(3) Patients received at the treatment facility in the PPW are checked for contamination; if they are free of contamination, they may be processed through the litter airlock in the PPW. The inside medical personnel ensure that the inner litter airlock door is closed. The outside medical personnel open the outer airlock door and place the litter on the litter rails/stands when using the TALP or on the floor and push the patient into the litter airlock headfirst, then close the outer door.

(4) Purge the airlock for 3 minutes. After the purge time, medical personnel inside of the CPS open the inner airlock door and use the CAM/ICAM/M8 to check the patient to

ensure that he is free of contamination. If no contamination is found, the inside medical personnel remove the patient from the airlock. As the patient is removed from the airlock, the PPW is opened and rolled inside out so that any desorbing vapors are adsorbed by the charcoal layer. The inside medical personnel remove the patient from the airlock and position him on litter stands. The patient is transferred to a clean litter; then moved to the treatment area.

(5) The receiving litter and PPW are returned to the outside. The PPW must be disposed in the contaminated waste dump. Decontaminate the litter and return it to the litter pool.

---

Note: Should contamination be found when monitoring the airlock, repeat the purge cycle, and then retest for contamination. All vapor hazards must be eliminated before the patient is moved into the CPS. Repeating the purge cycle may NOT be possible if the patient is in need of immediate lifesaving care. The patient may have to be returned to the outside treatment area for immediate care.

---

c. Exit Procedures.

(1) The litter patient is placed in a PPW. A battery-operated blower unit with a CB filter is attached to the PPW to provide fresh air to the patient; thus reducing the heat load on the patient and the carbon dioxide buildup inside the PPW.

(2) An inside medical personnel notifies an outside medical personnel that the patient is ready to exit the shelter. Outside medical personnel ensures that the outer airlock door is closed. The patient is placed in the litter airlock feet first. The inner airlock door is closed. The outside medical personnel opens the outer door and removes the patient.

(3) Staff, visitors, or ambulatory patients exit through the ambulatory airlock. Before entering the airlock, each individual must ensure that the outer airlock door is closed. The individual enters the airlock and closes the inner door; puts on his protective mask and exits through the outer door. The individual puts on his BDU/ACU and boots, and then assumes the established MOPP level before departing the immediate area of the exit door.

**WARNING**

**Do not open the outer door until the inner door has been closed. Do not allow patients in PPW to remain in direct sunlight for more than 5 to 10 minutes. Remaining in direct sunlight can cause severe heat load on patients.**

---

Note: Exits must be spaced at least 3 minutes apart to allow for a complete purge cycle of the airlock.

---

d. Resupply of Protected Areas. Resupply of protected areas is accomplished by placing contamination-free supplies or equipment on a litter and passing it through the litter airlock, or processing it through the supply airlock. The litter airlock must be purged for 3 minutes. The supplies must be checked for contamination before they are removed and placed within the CPS. The supply airlock must be purged for the stated time as outlined in the supporting TM; usually 45 minutes. Again the supplies must be checked for contamination before they are removed and placed within the CPS.

**This page intentionally left blank.**



## Appendix A

# CHEMICAL, BIOLOGICAL, RADIOLOGICAL, AND NUCLEAR CASUALTY ESTIMATION

### 1. Decision Support Tool

Medical planners' estimates (such as casualty, logistics, evacuation, and personnel cross leveling) must be modified for the CBRN environment. Estimates of CBRN medical workloads can be found in the AMedP-8 Publication. A number of new decision support tools under development have various levels of capability to estimate the number and types of casualties from CBRN events. Data from these models can be used to develop medical estimates. Information such as units affected, number of casualties, and severity and time course of illness can be obtained in order to estimate the medical force structure necessary and Class VIII requirements and to develop and wargame medical support COAs.

### 2. Casualty Estimates

The joint tool approved for calculating medical requirements is the medical analysis tool (MAT). However, the MAT includes the capability to generate medical requirements for CBRN casualties. The DMSB develops task, time, and treater files for use in the MAT for various CBRN casualty profiles. These files can be used to determine Class VIII equipment and supply requirements. The Services are responsible for generating their respective casualty estimates and tracking casualty rates for contingency operations. In the USAF, this is the responsibility of the planning and operations communities.

### 3. Joint Effects Model

a. The JEM provides for a near real-time visualization of CBRN hazards on the operational environment. The Army's capability to detect, identify and report CBRN hazards is improving. However, the capability to accurately project areas of contamination on the operational environment is still limited to ATP-45(C) standards. This improved situational awareness will better enable commanders to protect forces in the actual areas of contamination; continue the mission unencumbered with forces that previously would have been falsely warned and placed in MOPP 4; and conserve limited decontamination assets.

b. The JEM supports the JWARN. The JWARN will receive data from sensor platforms or manually. This data will be formatted by JWARN and made available to JEM. The analyzed data and resulting hazard predictions will be transmitted to JWARN in order to provide hazard warning to forces and the facilities that are potentially affected. Planning for such events is accomplished by chemical staff sections at the tactical, operational, and strategic levels of Army and Joint forces using the planning modes of the JEM.

c. The JEM will be a resident on all air defense artillery and C4ISR systems and stand alone personal computers and laptop computer systems of the Chemical Corps staff sections within the chemical brigade, corps, EAC, JTF, and unified combatant commands. It will interoperate with the Army Battle Command Systems. It will provide forces with an integrated comprehensive analysis and response capability, which will minimize the effects of hostile air and missile attacks employing CBRN agents. In addition, automatic or manual input weather data can be used as necessary/required. The JEM Block I will predict the probability of contamination following the use of CBRN WMD by hostile forces, the deliberate release of toxic inhalation hazard (TIH) by hostile forces, and the unintentional release of CBRN/TIH materials resulting from offensive strike missions by US or Allied forces. The JEM Block I will combine the unique capabilities of the three existing models

designated as DOD interim standards: vapor, liquid and solid tracking, HPAC, and Downwind Distance/Dispersion Puff.

d. The JEM will output basic computation of the transport and diffusion. It will compute other effects (absorption, adsorption, desorption), chemical reaction, decay, or neutralization) and determine the toxic hazard for a given breathing rate, skin exposure, or protection level. It will display graphical output and map the hazard onto a population density. Block II of JEM will add the capability to predict hazard areas and probabilities of contamination from intercepts of ballistic missiles carrying WMD payloads and from CBRN events occurring in urban areas.

e. The JEM can also be used as an operational planning tool designed to allow the chemical staff and with coordination, the medical staffs at operational and strategic theater levels of war to conduct analysis of potential impact of TIH and CBRN threats on critical locations (such as aerial port of debarkation [APOD]/sea port of debarkation [SPOD] and other fixed-sites) and population base on friendly operations. Such information will be useful to the commander in formulating the CBRN defense plans and in selecting defensive posture and procedures, as well as asset allocation for such operations.

#### **4. Joint Operational Effects Federation Model**

a. The joint operational effects federation (JOEF) model, scheduled for fielding in FY 09 will provide advance planning and analysis capability, as well as a near real-time dynamic staff action support tool capability, including reach back. The JOEF will accurately depict the CBRN warfare environment, including sensor/system deployment and the operational effects and impacts on personnel, equipment, and operations. It will provide a computer-based, federated software system capable of providing deliberate planning support for the development of CBRN defense (CBRND) operational plans and near real-time decision aids in a combat environment. The federated capability approach will allow the JOEF to be tailored to specific user needs. The JOEF also supports incident management users by providing an information management system that supplies information to aid in limiting the adverse consequences of the incident as it relates to CBRND.

b. The JOEF will provide information on operational effects, impacts, and risks associated with CBRN events on current and future operations, across all networked C4I systems. It will provide decision support tools and software sets that will assist operational planners in the following CBRND-related tasks:

- Determining the operational effectiveness of proposed systems.
- Recommending operational units for a mission.
- Developing TTPs.
- Training, planning, and preparing for military operations.

c. The system will enable the operational commander to more efficiently execute *what if* planning scenarios and facilitate the evaluation of COAs, to include branches and sequels.

d. The JOEF will support mission environments at the strategic, operational, and tactical levels of warfare in deliberate and crisis-action planning, as well as incident and incident management. The CBRND planners on the JFC staff are the primary users of JOEF. It will accept a variety of automatic inputs (such as JEM, intelligence, logistics, and medical), as well as manual inputs. It will support all warfare domains in all phases of operation, including mobilization, employment, sustainment, and redeployment. Additionally, JOEF will be used to perform analysis in support of operational planning and to conduct wargaming and training activities.

(1) There are five mission essential functions performed by JOEF:

- Operational effects.
- Risk evaluation and assessment.
- Planning support.
- Resource allocation.
- Medical support.

(2) The JOEF implements these functionalities to provide an enhanced CBRND capability for the warfighter.

e. The JOEF will focus on the operational mission environment. The operational mission environment users consist of war planners, theater planners, fixed-site forces, mobile forces, and medical support. It will support these operational users in their deliberate planning by supplying impact and risk estimates of CBRN threats and potential CBRN events. It will also support these operational users in their deliberate planning by simulating work processes and determining mission measures of effectiveness resulting from their TTPs when encountering CBRN hazards. It will also support these operational users during incident management by supplying recommended actions in near real time from the deliberate plans and the analysis of mission effectiveness resulting from established, as well as tailored, TTPs.

f. The JOEF will support tactical mission environment users in deliberate and, to a lesser degree, crisis action planning by calculating resources needed, by recommending COAs, and by providing deliverables such as checklists and impact and risk assessments. It will support these users in their near real-time crisis planning during and after a CBRN event by supplying CM tools and services. The JOEF decision support tools will complement the decision support tools provided by the JWARN at the tactical level of warfare in current operations, as well as during CM phases. Although JOEF will be capable of supplying higher resolution decision support products into the tactical level, as well as into the strategic level, planners will use it with a focus at the operational level and in the deliberate planning and early crisis action phases of an operation.

g. The JOEF will include a casualty estimation tool capable of enabling prior planning for medical operations in a CBRN environment and will provide the medical planner with a tool set to estimate CBRN casualties from which casualty rates, medical force structure, and medical logistics requirements can be determined.

**This page intentionally left blank.**

**Appendix B**  
**HEALTH SERVICE SUPPORT CHEMICAL, BIOLOGICAL,  
RADIOLOGICAL, AND NUCLEAR ANNEX TO AN OPERATION  
PLAN/OPERATION ORDER**

**1. Medical Chemical, Biological, Radiological, and Nuclear Staff Officer Planning for Health Service Support in a Chemical, Biological, Radiological, and Nuclear Environment**

a. PURPOSE. To establish standardized procedures for medical CBRN staff officer planning, preparing for, detecting, reporting, and providing preventive/protective measures for CBRN/TIM hazards. To establish planning procedures for conducting HSS in CBRN/TIM environments. Also, to establish procedures for providing technical guidance/support to leadership before, during, and after a CBRN/TIM event.

b. PROCEDURES. Medical CBRN staff officers prepare the list of equipment and procedural guidelines for HSS operations under CBRN/TIM conditions. *(Provide a list of radiological detection devices, chemical agent detection/identification kits/devices, components of biological sample/specimen collection, and shipping containers. Provide guidelines/references for operating detection/identification devices.)*

(1) Planning actions for use before a CBRN/TIM event. *(Provide preventive/protective measures that the leadership can employ to reduce the health effects of a CBRN/TIM event. Also, provide preventive/protective measures that leadership can employ to reduce the health effects of existing CBRN/TIM hazards/contamination in an AO. Provide HSS leadership with procedures that can be employed to protect their unit and patients.)*

(2) Planning action for use during a CBRN/TIM event. *(Provide preventive/protective measures that the leadership can employ to reduce the health effects of a CBRN/TIM event. Provide HSS leadership with procedures that can be employed to protect their unit and patients.)*

(3) Planning actions for use after a CBRN/TIM event. *(Provide preventive/protective measures that line leadership can employ to reduce/mitigate the health effects of a CBRN/TIM event on the force. Provide HSS leadership with procedures that can be employed to mitigate the effects on their unit and patients.)*

(4) Planning actions for PVNTMED support for CBRN/TIM events. *(Provide types and numbers of PVNTMED units/personnel required to perform PVNTMED missions during such events. Describe mission requirements for units/personnel preparing for and reacting to the event. Describe types of samples/specimens required and how samples/specimens must be collected, preserved, packaged, and shipped to supporting medical laboratory for analysis. Describe detection/monitoring equipment required for the event.)*

(5) Planning actions for veterinary support for CBRN/TIM events. *(Provide types and numbers of veterinary units/personnel required to perform the veterinary service missions during such events. Describe mission requirements for units/personnel preparing for and reacting to the event. Describe types of samples/specimens required and how samples/specimens must be collected, preserved, packaged, and shipped to supporting medical laboratory for analysis. Describe food contamination and decontamination procedures. Describe detection/monitoring equipment required for the event.)*

(6) Planning actions for medical laboratory support for CBRN/TIM events. *(Provide requirements for medical laboratory support for a CBRN/TIM event. Describe types of*

*laboratory test/procedures required to provide command verification on the use of a suspect CBRN device/weapon. Provide medical laboratory reporting requirement. Examples: Provide report to command surgeon; JTF/Service component commander; senior commander in affected operational area).*

(7) Planning actions for HSL support for CBRN/TIM events. *(Determine requirements for HSS support units and personnel. Describe types of Class VIII supplies required to support HSS response to an event. Example: Numbers of chemical agent patient decontamination MESSs, chemical agent patient treatment sets, number of packets of chemical agent pretreatment tablets required, and chemoprophylaxis required for personnel exposed to a biological agent.)*

(8) Planning actions for COSC/BH support for CBRN/TIM events. *(Provide requirements for COSC/BH support units/personnel. Describe where and how COSC/BH personnel will provide their support in response to the event.)*

(9) Planning for medical treatment of CBRN/TIM event casualties. *(Provide requirements for medical evacuation and treatment [including emergency dental care] support units/personnel. Provide requirements for nonmedical personnel to perform patient decontamination at the PDS and MTF. Describe where and how evacuation and treatment personnel will provide their support in response to the event, to include supervision of patient decontamination procedures.)*

c. COORDINATION REQUIREMENTS. *(Provide requirements for support such as who should transport/escort samples/specimens from unit of origin to the supporting medical laboratory and on to the CONUS definitive laboratory. Example: The 22d Chemical Battalion Technical Escort [TE] normally provides transportation and escort for suspect CBRN samples, in their absence describe who will provide this service. Provide requirements for numbers of personnel required to perform patient decontamination at supporting MTFs. Describe decontamination support requirements for medical units; especially hospitals and major HSL facilities.)*

d. REPORTS. *(Describe types of reports required and frequency of reporting on CBRN aspects of CBRN/TIM events. Reports should provide, at a minimum, aspects of event and recommended preventive/protective actions needed to prevent or minimize casualties.)*

## **2. Sample Format for the Health Service Support Plan for Chemical, Biological, Radiological, and Nuclear Operations**

(Classification)
Copy ___ of ___ copies Headquarters Location Date, time, and zone
Name of OPLAN and OPLAN number
References: <i>List all maps, overlays, charts, or other documents required to understand the plan. Reference to a map will include the map series number and country or geographic area, if required; sheet number and name, if required; edition; and scale.</i>
(Classification)

(Classification)

1. **SITUATION** *(Provide information essential to understanding the plan.)*

a. **General.** *Describe the CBRN environment that would establish the probable pre-conditions for execution of the plan.*

b. **Area of Concern.**

(1) **Area of Responsibility.** *(Describe the command surgeon's area of responsibility. A map may also be included as an attachment.)*

(2) **Area of Interest.** *(Describe the general area of interest covered by the command surgeon's concept and/or basic plan. This description should address all air, ground, and sea areas that directly affect the HSS operation. A map may also be included as an attachment.)*

(3) **Operational Area.** *(Describe the specific areas covered in each option contained in the command surgeon's concept and/or basic plan. Maps may also be included as attachments.)*

c. **Deterrent Options.** *(Delineate deterrent options desired to include those categories specified in the current command surgeon's concept and/or basic plan. Specific units and resources to include possible diplomatic, informational, or economic deterrent options accomplished by non-DOD agencies that would support HSS mission accomplishment.)*

d. **Enemy Forces.** *(Emphasis on capabilities bearing on the plan by terrorist groups, insurgents, host nation forces, or other opposition groups or political factions found in a particular country.)*

e. **Friendly Forces.** *(Emphasis is also placed on CBRN HSS functions and responsibilities for higher and adjacent units. Are HSS facilities susceptible to CBRN weapons?)*

(1) **Identify friendly forces centers of gravity.** *(The health of the command can have a significant impact on the volume of casualties from CBRN weapons.)*

(2) **Describe the operations of unassigned forces, other than those tasked to support this operation.** *(A composite risk management assessment of current and projected operations of unassigned forces in a CBRN environment determines if adequate HSS systems are capable of providing proper operational support.)*

(3) **List the specific tasks of friendly forces that would directly support HSS execution.** *(Identify the remaining medical units and list their respective tasks and missions.)*

f. **Assumptions.** *(List all assumptions, including common HSS assumptions that, should they occur or not occur as expected, would invalidated the entire plan.)*

g. **Legal Considerations.** *(List those significant HSS legal considerations on which the plan is based.)*

(Classification)

(Classification)

2. **MISSION** *(Statement of the overall HSS mission and type of activity to be supported.)*

3. **EXECUTION**

a. **Concept of operations.** *(The concept of operations describes how the command surgeon sees the actions of subordinate units fitting together to accomplish the HSS mission. The command surgeon ensures that the concept of HSS operations in a CBRN environment is consistent with the commander's intent and that of the next two higher headquarters. The concept of operations describes any other details the command surgeon considers appropriate to clarify the concept of operations and ensures unity of effort. When an operation involves two or more clearly distinct and separate phases, the concept of operations may be prepared in subparagraphs describing each phase.)*

(1) **Commander's Intent.** *(Describe the command surgeon's intent, and the intent by phase. Describe the desired end state.)*

(2) **General.** *(Base the HSS concept of operations on the commander's estimate of the situation.)*

(3) **Deployment.** *(Summarize the HSS concept of operations to place HSS forces, equipment, and medical supplies in the operational area.)*

(4) **Employment.** *(Describe the concept of how the HSS forces are employed in each of the phases contained in the OPLAN.)*

b. **Tasks.**

(1) *(List the HSS tasks assigned to each element of the supported and supporting commands.)*

(2) *(State the HSS tasks that each Services is expected to provide for another.)*

c. **Coordinating Instructions.** *(List the instructions applicable to two or more Services or organizations that are necessary for proper coordination.)*

4. **ADMINISTRATION AND SUPPORT**

a. **Concept of Support.** *(Refer to TSOP or another annex whenever practical.)*

b. **Logistics.** *(Provide special instructions applicable to HSS units. Also consider stockage levels for all classes of supply, as units will be operating in an austere environment created by CBRN weapons and at extended distances from the full complement of sustainment and logistics resources.)*

(1) **Health service logistics** (to include blood and blood products). *(Provide special Class VIII supplies and equipment for patient decontamination and treatment.)*

(a) **Requirements.** *(For sustaining US, allied, coalition, or host nation forces and other eligible beneficiaries are addressed in subparagraph [3] below.)*

(Classification)



(Classification)

(b) Procurement. *(Provide detailed information on resupply and stockage levels required and/or contracting support for the operation.)*

(c) Storage. *(Special procedures and equipment requirements for maintaining storage and the appropriate shelf life of medical materials in a contamination free environment should be included.)*

(d) Distribution. *(This should include the method of distribution and any limitations or restrictions that are applicable. Additionally, if special transportation requirements exist, they should also be noted.)*

(2) Supplies required to accomplish HSS operations in a CBRN environment. *(This includes humanitarian assistance, disaster relief, or HSS missions.)*

(a) Requirements. *(Includes estimates of the population to be supported or the number of patients anticipated to be treated.)*

(b) Coordination. *(Interservice, allied forces, US agencies, coalition forces, host nation government, the nongovernmental organizations, and international organizations should be included.)*

(3) Other HSL matters. *(Address any requirements for sustaining US, allied, coalition, or host nation forces and other eligible beneficiaries.)*

(4) Transportation and Movements. *(This includes medical use of various transportation means.)*

(a) General. *(Transportation availability in a contaminated and noncontaminated environment.)*

(b) Ground. *(The availability of ground evacuation assets to sustain US forces should be discussed. Coordination for use of allied, coalition, or host nation forces evacuation assets should also be included.)*

(c) Rail. *(If available, the treatment locations could be established along the railway, or it could provide a means for the civilian population to travel to a treatment area, or to move the medical team and equipment.)*

(5) Water. *(Considerations should include both inland and at sea transportation requirements or assets and the availability of shipboard facilities for evacuation and treatment.)*

(6) Air. *(The availability of AE support for the supported force should be discussed. Additionally, the assessment of AE requirements for a host nation or US-backed group, the development of a medical evacuation system, and the training of appropriate personnel to operate in a CBRN environment.)*

**c. Services.**

(1) Services to HSS units and facilities. *(Include information on the following services: laundry, bath, utilities, fire fighting, construction, real estate, graves registration, mortuary affairs, religious, personnel, and finance.)*

(2) Medical equipment maintenance. *(Include decontamination of equipment.)*

(Classification)

(Classification)

**5. COMMAND AND SIGNAL**

a. **Command.** *(State the map coordinates for the command post (CP) locations and at least one future location for each CP. Identify the chain of command if not addressed in unit SOPs.)*

b. **Signal.** *(Include the headquarters location and movements, liaison arrangements, recognition and identification instructions, and general rules concerning the use of communications and other equipment, if necessary. Use an annex when appropriate.)*

s/ \_\_\_\_\_  
t/  
(Commander/Command Surgeon)

Appendixes

DISTRIBUTION: *(Is determined locally.)*

(Classification)

## **Appendix C**

# **SERVICE-SPECIFIC TASKS LIST**

### **1. United States Army Tasks List**

a. This is not a comprehensive listing of HSS CBRN tactical-level collective tasks. The listed Army Universal Task List (AUTL) (FM 7-15) complements the Universal Joint Task List (UJTL) by providing tactical-level Army-specific CBRN tasks. The AUTL—

- Provides a common, doctrinal structure for collective tasks that support Army tactical missions and operations performed by Army units and staffs.
- Articulates what tasks the Army performs to accomplish missions, but does not describe how success occurs.
- Applies to all four types of military operations (offense, defense, stability, and civil support).
- Provides standard definitions and helps establish a common language and reference system for all tactical echelons (from company to corps) and tactical staff sections.

b. Army tactical tasks (ARTs) apply at the tactical level of war. Although the AUTL emphasizes tasks performed by Army units, the Army does not go to war alone. Therefore, the AUTL includes tactical tasks typically performed by other Services to support Army forces.

(1) ART 5.3.2 Conduct Nuclear, Biological, and Chemical (NBC) Defense. Defend against NBC weapons using the principles of avoidance, protection, and decontamination. The ART 5.3.2 includes protection from agents deliberately or accidentally released. An example of an accidentally released agent is toxic chemicals leaking from factory storage containers due to collateral damage. (FM 3-100) (Superseded by FM 3-11.) (United States Army Chemical School [USACMLS])

(2) ART 5.3.2.1.1 Employ Contamination Avoidance. Take measures to avoid or minimize the effects of NBC attacks and reduce the effects of NBC hazards. By taking measures to avoid the effects of NBC attacks, units can reduce their protective posture and decrease the likelihood and extent of decontamination required. (FM 3-3) (Superseded by 3-11.3.) (USACMLS)

(3) ART 5.3.2.1.5 Use Individual/Collective Nuclear, Biological, and Chemical Protective Equipment. Take action that allows Soldiers to survive and continue the mission under NBC conditions. (FM 3-4) (Superseded by FM 3-11.4.) (USACMLS)

(4) ART 5.3.2.2 Decontaminate Personnel and Systems. Make any person (US military, coalition military, civilians, and EPWs), object, or area safe by absorbing, destroying, neutralizing, making harmless, or removing nuclear, biological, or chemical material/agents clinging to or around it. (FM 3-5) (superseded by FM 3-11.5) (USACMLS) This includes ART 5.3.2.2.1 Perform Immediate Decontamination; ART 5.3.2.2.2 Perform Operational Decontamination; and ART 5.3.2.2.3 Perform Thorough Decontamination.

(5) ART 5.3.2.2.4 Perform Area Decontamination. Decontaminate fixed sites and terrain to restore the area to an acceptable level of readiness and effectiveness, while conducting the mission. Limit the spread and transfer of contamination, restore mission essential functioning, and open accessibility for entry and exit to key facilities. Fixed sites include command posts, signal facilities, supply installations and points, depots,

pre-positioned materiel, airfields, and port facilities. (FM 3-5) (Superseded by FM 3-11.5.) (USACMLS)

(6) ART 5.3.2.2.5 Perform Patient Decontamination. Decontaminate patients who are unable to decontaminate themselves through the systematic removal of clothing and contaminants. A patient decontamination team consisting of nonmedical personnel from the supported unit performs patient decontamination. The patient decontamination team operates under the supervision of medical personnel to ensure the decontamination process causes no further injury to the patient. (FM 4-02.7) (See Chapter V of this publication.) (USAMEDDC&S)

(7) ART 6.5 Provide Force Health Protection In A Global Environment. Force health protection in a global environment (FHPGE) is a continuum of care and prevention from predeployment, to deployment, to postdeployment. The FHPGE mission (executed by the HSS system) starts with service entry and is focused on maintaining a fit and effective Soldier during garrison operations and while deployed. Provision of these services stretches from the forward edge of an operational area through the national level sustaining base medical facilities. The challenge will be to simultaneously provide health care support to deploying forces, provide health care services to the sustaining base, establish an effective HSS system within the theater, and support the potential for lesser conflicts and/or support and sustainment operations. Additionally, post conflict health care support is required for redeployment and demobilization. Force health protection in a global environment identifies AMEDD required capabilities to support operational warfighting concepts across the operational continuum. (FM 4-02) (USAMEDDC&S)

(8) ART 6.5.1 Provide Combat Casualty Care. Casualty care encompasses a number of AMEDD functional areas. It groups organic and area medical support, hospitalization, the treatment aspects of dental care and mental health (MH)/neuropsychiatric (NP) treatment, clinical laboratory services, and the treatment of NBC patients. (FM 4-02) (USAMEDDC&S) The preventative aspects of dentistry and COSC are addressed under ART 6.5.4, Provide Casualty Prevention.

(9) ART 6.5.1.1 Provide Medical Treatment (Organic and Area Medical Support). Provide medical treatment (organic and area medical support) for all units within the AO. Examine and stabilize patients. Evaluate wounded and DNBI. Examine the general medical status to determine treatment and medical evacuation precedence. (FM 4-02) (USAMEDDC&S)

(10) ART 6.5.1.2 Provide Hospitalization. Hospitalization resources are MTFs which are capable of providing inpatient care and services. Hospitalization continues the medical care provided at Levels I and II of the HSS system. It also provides a far forward surgical capability which provides essential care in theater, outpatient services, and ancillary support (pharmacy, clinical laboratory, radiology services, and nutrition care). Within theater, the hospitalization capability includes returning those patients to duty within the limits of the theater evacuation policy. This conserves the fighting strength by returning trained manpower to the tactical commander. It also provides stabilizing care to facilitate the evacuation of those patients who will not recover from their injuries or illnesses within the stated theater evacuation policy to facilities capable of providing required care. Theater hospitals may be augmented with hospital augmentation teams to provide specific specialty care. (FM 4-02.10) (USAMEDDC&S)

(11) ART 6.5.1.3 Provide Dental Services. Prevent and treat dental disease and injury. ART 6.5.1.3 includes providing operational dental care, which consists of emergency dental care and essential dental care, and comprehensive care which is normally only

performed in fixed facilities in CONUS or in at least a Level III facility. (FM 4-02.19) (USAMEDDC&S)

(12) ART 6.5.1.4 Provide Clinical Laboratory Services. Perform clinical laboratory diagnostic procedures in support of medical treatment activities. (FM 4-02.10) (USAMEDDC&S)

(13) ART 6.5.1.5 Provide Mental Health/Neuropsychiatric Treatment. Provide medical treatment for mental health and neuropsychiatric medical conditions. (FM 8-51) (Superseded by FM 4-02.51.) (USAMEDDC&S)

(14) ART 6.5.2 Provide Medical Evacuation (Air/Ground). Evacuate sick, injured, or wounded personnel (US, allied, coalition, and host nation forces, enemy prisoners of war, detained/retained personnel, and when authorized, civilian personnel) from the point of injury or wounding to a medical treatment facility in a timely and efficient manner while providing en route medical care. (FM 8-10-6) (Superseded by FM 40-2.2.) (USAMEDDC&S)

(15) ART 6.5.2.1 Provide Medical Regulating Support. Medical regulating entails identifying the patients awaiting evacuation, locating the available hospital beds, and coordinating the transportation means for movement. The formal medical regulating systems begin at Level III hospitals. (FM 8-10-6) (See also FM 4-02.2.) (USAMEDDC&S)

(16) ART 6.5.3 Provide Medical Logistics. Provide Class VIII medical materiel, medical equipment maintenance (to include medical peculiar repair parts), optical fabrication and repair, and blood management for all US Army forces. When serving as the AO single integrated medical logistics manager, supply of medical materiel will be extended to other Services. (FM 4-02.1) (USAMEDDC&S)

(17) ART 6.5.3.1 Provide Medical Equipment Maintenance and Repair. Provide medical equipment maintenance and repair of deployed medical equipment. (FM 4-02.1) (USAMEDDC&S)

(18) ART 6.5.3.2 Provide Optical Fabrication. Provide manufacturing of single and multivision lens and eyewear repair. (FM 4-02.1.) (USAMEDDC&S)

(19) ART 6.5.4 Provide Casualty Prevention. Casualty prevention is the AMEDD's integrated and focused approach enabling the Army to promote and sustain a healthy and fit force and to prevent casualties from disease, nonbattle injuries, NBC, occupational and environmental health (OEH) hazards, and combat operational stress reactions. It encompasses capabilities from the following AMEDD functional areas (preventive medicine—including medical surveillance and occupational and environmental health surveillance—veterinary services—including the food inspection and animal care missions, and the prevention of zoonotic diseases transmissible to man), COSC prevention, dental services (preventive dentistry), and laboratory services (area medical laboratory support). (FM 4-02) (USAMEDDC&S)

(20) ART 6.5.4.1 Provide Preventive Medicine Support. Prevent disease and nonbattle injuries through the establishment of preventive medicine programs such as, field hygiene and sanitation, disease surveillance, immunizations, chemoprophylaxis, and education in personal protective measures. (FM 4-02.17) (USAMEDDC&S)

(21) ART 6.5.4.2 Perform Medical Surveillance. Perform medical surveillance, to include the collection and analysis of health status and medical threat information before, during, and following deployment. Ensure common awareness of potential medical threats and monitor implementation of preventive medicine measures. (FM 4-02.17) (USAMEDDC&S)

(22) ART 6.5.4.3 Perform Occupational and Environmental Health Hazard Surveillance. Perform occupational and environmental health (OEH) hazard surveillance. (FM 4-02.17) (USAMEDDC&S)

(23) ART 6.5.4.4 Provide Veterinary Services. Serve as the DOD executive agent for veterinary services for all Services. Perform food safety surveillance, which includes food hygiene and quality assurance, inspection of Class I sources, microbial analysis of food, and temperature monitoring of transported and stored food supplies, and to assess potential health hazards in the AO; identify, evaluate, and assess animal diseases of military significance; and provide complete veterinary health care to DOD MWDs and any other government-owned animals in the AO. (FM 8-10-18) (Superseded by FM 4-02.18.) (USAMEDDC&S)

(24) ART 6.5.4.5 Provide Combat and Operational Stress Control Prevention. Provide COSC prevention by establishing prevention programs, conducting critical event debriefings, and providing consultation and educational services. (FM 8-51) (Superseded by FM 4-02.51.) (USAMEDDC&S)

(25) ART 6.5.4.6 Provide Area Medical Laboratory Services. Identify, evaluate, and assess health hazards in the AO. This task includes providing endemic disease laboratory services, occupational and environmental laboratory services, and NBC laboratory services. (FM 4-02) (USAMEDDC&S)

(26) ART 6.5.4.7 Provide Preventive Dentistry Support. Military preventive dentistry incorporates primary, secondary, and tertiary preventive measures taken to reduce or eliminate oral conditions that decrease a Soldier's fitness to perform his mission and cause absence from duty. (FM 4-02.19) (USAMEDDC&S)

## **2. United States Air Force Task List**

a. Air Force Tasks Pertaining to Health Service Support in a Nuclear, Biological, and Chemical Environment:

- Appendix C of AFDD 1-1 includes a comprehensive framework for expressing all Air Force tasks (AFT); however, it is not a comprehensive list of every task performed by the Air Force. Air Force organizations are authorized and encouraged to add to or modify these tasks as needed to express their mission-specific activity.
- Commanders can also refer to Air Force Medical Service CONOPS and AFTTPs for the most current Air Force guidance related to operations in a CBRN environment. This will also assist in the development of mission-essential task lists (METLs) as outlined in AFDD 1-1.

b. The following sampling of AFTs is pertinent to HSS operations in an NBC threat environment. This list is not comprehensive. The narrative under the AFTs is provided to serve as a guide to initiate ideas to develop METLs that include HSS NBC concerns.

(1) The AFT 3.1.1.1.2 Perform Surveillance. Carry out procedures for the collection of NBC data obtained from sampling and HSS systems to evaluate disease trends, incorporating information from decontamination teams and MTFs in the AO to determine NBC agent type.

(2) The AFT 5.1.4 Plan Airlift Functions. Appropriate timing for the deployment of HSS and EMDT assets in theater to meet a possible NBC threat. Coordinate HSS medical evacuation scenarios where there are NBC casualties with infectious diseases or other NBC

contaminants. Coordinate with USTRANSCOM for staging and movement of NBC-contaminated casualties as well as timed movement of HSS assets into and out of the TO.

(3) The AFT 5.4 Provide Air and Space Expeditionary Force (AEF) Capabilities. Ensure adequate predeployment training is performed to include self-aid and buddy care related to NBC, IPE wear and mask fit tested, inoculation, and training to enhance knowledge of NBC threat. Predeployment medical assessments for ASETF assets conducted. Medical staff trained in the treatment of the NBC casualty. Wartime medical decontamination team personnel are trained adequately. Equipment and supplies needed for the adequate care of the NBC casualty are available and ready for deployment. Equipment sets are inventoried and complete. Decontamination equipment is complete. Health service support assets know how to access reachback resources for information and assets to treat NBC casualties. The HSS assets that provide NBC surveillance are adequately trained and equipped.

(4) The AFT 5.4.1 Perform AEF Functions. The HSS deployable assets rehearsed and equipment ready for immediate deployment. Programs in place to measure readiness of personnel and equipment/supply assets. Programs in place to maintain HSS at home facility with reduced staffing.

(5) The AFT 5.4.2 Educate and Train AEF Forces. Training cadre for medically related NBC issues identified at unit level. Units using training tools supplied by Air Force/Army/Navy related to NBC protection/casualty management. Trainers familiar with how to access training tools that are currently developed by all Services. Adequate predeployment training performed to include self-aid and buddy care related to NBC, IPE wear and mask fit tested, inoculation, and training to enhance knowledge of NBC threat. Medical staff trained in the treatment of the NBC casualties. The EMDT personnel trained adequately in triage, lifesaving treatment, and casualty/foodstuff decontamination procedures. The EMDT teams trained using their real world equipment sets. Adequate and appropriate equipment/supplies available for training to manage NBC casualties. Trainers identified to teach others about NBC issues. Health service support assets know how to access reachback resources for information and assets to treat NBC casualties once deployed. Health service support assets who provide NBC surveillance are adequately trained and equipped.

(6) The AFT 5.4.3 Equip AEF Forces. Equipment and supplies needed for the adequate care of the NBC casualty are available and ready for deployment. The NBC-related equipment sets are inventoried and complete. Decontamination equipment is complete. Health service support assets that provide NBC surveillance are adequately equipped. Supplies and equipment is adequate for training to ensure EMDT and medical personnel are trained to manage NBC mass casualty situations. The EMDT decontamination equipment is in good working order or procedures are in place to ensure prompt repair/replacement so that equipment package is deployment ready at all times.

(7) The AFT 5.4.4 Plan AEF Functions. Examine individual readiness of personnel assigned to deployable UTCs, equipment, and supply requirements related to NBC. Coordinate planning with other AEF agencies to ensure HSS can operate in an NBC-contaminated environment. Procedures in place to ensure that HSS information collected, relating to NBC, is shared with other AEF agencies and that HSS is active in the AEF planning process. Systems in place to assess HSS readiness related to NBC issues. Coordination with CE for decontamination site lay down to ensure correct drainage, water resupply approaches cleared, power hook up and contaminated waste disposal. Coordination for water resupply for decontamination operations.

(8) The AFT 6.1 Provide the Capability to Ready the Force. Health service support assets organized, trained, and equipped for all situations where NBC casualties will be received. Health service support trained/equipped to work in noncontaminated and contaminated environment with minimal equipment assets. The EMDT trained to decontaminate casualties without water resources. Health service support assets trained and equipped to operate for a sustained period in an NBC-contaminated environment or in an environment that is receiving contaminated casualties. The HSS assets trained to work in a situation with minimal infrastructure and in a forward area.

(9) The AFT 6.1.1.8 Provide Repairable and Consumables. Procedures appropriately assess NBC supply needs for HSS to include decontamination supplies, water for decontamination, and medical care consumables such as additional bandages, splints, and airways to replace contaminated items. Adequate supplies of mask filters and filters for chemically protected ASETF facilities on hand to provide for sustained operations in an NBC-contaminated environment. Adequate supplies of antidotes and antiseizure medications available for the treatment of NBC casualties. Systems in place to provide ongoing assessment of these items and restocking as needed.

(10) The AFT 6.1.1.9 Perform Maintenance. Health service support maintenance providers are familiar with repair of EMDT decontamination equipment or ready access to those who can repair. Reachback system established for prompt replacement of nonrepairable items.

(11) The AFT 6.1.1.13 Train a Quality Force. Health service support personnel proficient in NBC training. Medical staff proficient in caring for NBC casualties. Medical staff assigned to UTCs adequately trained to care for NBC casualties according to guidelines of AFTTP 3-42.3.

(12) The AFT 6.1.1.20 Support Joint Training. Health service support personnel familiar with procedures/practices of other Services related to NBC issues. Programs in place to encourage joint HSS training related to NBC.

(13) The AFT 6.1.1.22 Perform Organizational Performance Assessments. Evaluate effectiveness of care for NBC casualties and EMDT decontamination operations. Develop quantifiable measures for efficiency of decontamination/treatment operations.

(14) The AFT 6.1.1.22.3 Perform Task Assurance Assessments. Programs in place to measure an organization's ability to meet their HSS NBC-related tasks as derived from their METL.

(15) The AFT 6.1.2 Educate and Train Forces to Ready the Force. Requirements driven, high quality programs related to NBC issues are developed incorporated at unit. Health service support personnel receive NBC related training to treat NBC casualties. The EMDT trained to perform decontamination with and without decontamination equipment package. Utilization of existing, preprepared, DOD NBC medical management training resources.

(16) The AFT 6.2 Provide the Capability to Protect the Force. Health service support assets prepared to carry out force protection measures related to the NBC threat to include NBC surveillance, NBC detection, and HSS operational plans and procedures related to NBC for the protection of the AEF in all locations, under normal and adverse conditions. Health service support involvement with monitoring of AEF food and water supplies for NBC contamination.



(17) The AFT 6.2.1 Protect the Force. Policies in place to maintain the health of HSS personnel, protect supplies and personnel from NBC contamination, and protect water and food sources from NBC contamination or sabotage. The HSS tracking of disease. Engineering controls and procedural controls to protect AEF and medical assets from NBC threat. Physical security of the MTF.

(18) The AFT 6.2.1.1 Conduct Occupational Health, Safety, and Community Health Programs. Provide occupational and community health surveillance to ensure healthful and safe working and living conditions. Procedures/policies to conduct surveillance for NBC agents in the environment. Sampling, analysis, monitoring, and training to ensure survivability. Engineering controls, procedural controls, or personal protective equipment if warranted by exposure levels to protect AEF and medical assets from NBC threat.

(19) The AFT 6.2.1.2 Perform Force Protection. Health service support coordination to ensure active security programs designed to protect against sabotage/attack using NBC agents. Accomplished through planned and integrated application of combative terrorism, physical security, OPSEC, personal protective services, as supported by intelligence, counterintelligence, and other security programs. This task includes defensive, active, and offensive force protection operations and counter-measures designed to minimize the effects of or recovery from hostile activities or natural occurrences. The application of force protection includes all actions intended to deter, detect, and defeat hostile acts against USAF treasures of airpower. This can include a combination of conventional and NBC threats.

(20) The AFT 6.2.1.4 Utilize and Maintain Forces to Protect the Force. Consider readiness of HSS EMDT if there are requirements from AEF and MTF for these personnel to help provide security to protect the force in an NBC threat environment.

(21) The AFT 6.3.1 Prepare the Operational Environment. Appropriate use of trained bio-environmental and public health UTC to assess potential HSS laydown area. Consideration of NBC threat. Consider area needed for set up of EMDT decontamination operations to include contamination runoff, storage area for contaminated waste, area for water bladders, routing of water resupply trucks, triage areas, and distance from supported MTF. Consideration of relative wind direction in NBC threat environment to place MTF upwind of decontamination area. Health service support close coordination with CE assets to provide hardening of MTF facilities if an NBC artillery/rocket attack threat is expected should also be part of this planning.

(22) The AFT 6.3.1.1.2 Determine Local Contracting Capability. Determine the availability of commercial support capability and propensity for support in the event of NBC contamination of the HSS facility. Determine if adequate water supplies are available for NBC decontamination operations. Find out if these contracted services can be supplied in an NBC-contaminated environment and, if not, develop alternative plans.

(23) The AFT 6.3.1.1.3 Determine Facilities Availability. Determine the areas' facilities suitability and availability if area is in NBC attack. Suitability of facilities as hardened protection against NBC threat. Capability of facilities to be modified to provide protection in the event of an NBC attack or area contamination.

(24) The AFT 6.3.1.2.2 Tailor Force Packages. Health service support force packages properly prioritized with adequate decontamination capability to meet an NBC threat if the force is deployed to an operational area that has a high likelihood of an NBC attack. Decontamination teams are staged early enough in the time-phased deployment. Adequate medical personnel packages are in place to treat casualties from an NBC attack.

The EMDT staffing is adequate to sustain decontamination operations for long periods of time considering anticipated NBC casualties, weather, and other factors.

(25) The AFT 6.3.1.4.4 Determine Resupply Routes and Channels. Consider resupply of atropine and antiseizure medications in high nerve agent threat area. Resupply of protective mask filters and protective garments, resupply of bandages that will need to be replaced due to chemical contamination, and resupply of NBC surveying supplies.

(26) The AFT 6.6.1 Sustain the Force. Provisions for replacement of HSS staff affected by NBC attack. Ability of HSS assets to operate in contaminated environment.

(27) The AFT 6.6.1.4 Perform Medical Support Activities. Management of NBC casualties in the AO for short and long durations, management of infectious patients not ready for air evacuation, and maintains medical care in an NBC-contaminated environment.

(28) The AFT 6.6.1.9 Provide Services Support. Health service support coordination with Services support for management of NBC contaminated waste. Coordination between HSS and mortuary affairs in NBC environment.

(29) The AFT 6.6.1.9.1 Provide Food Service Support. Health service support assets assist in management/decontamination of NBC contaminated food supplies.

(30) The AFT 6.6.1.11 Provide Water. Provide adequate amounts of safe drinking water. Coordination of water for EMDT decontamination. Determine potability of source and adequacy of treatment through sampling for NBC components. Routinely monitor distribution system for indicators of contamination. Recommend emergency treatment or alternative sources, as needed. Ensure bottled water is from approved source.

(31) The AFT 6.7 Provide the Capability to Recover the Force. Consider HSS health survey process for redeploying AEF forces. Units must perform needed decontamination of equipment and supplies, and dispose of contaminated items and contaminated waste. Sustained health follows up related to NBC issues after deployment in a contaminated area.

### **3. United States Navy Tasks List**

a. The US Navy does not consider CBRN a universal task, but a condition. Unlike the US Army and US Air Force, the US Navy does not have a Service specific task list that addresses CBRN.

b. The below tasks are HSS Navy METL which can be used as a blanket set of Naval tactical tasks (NTA) to reflect CBRN.

(1) Navy Tactical Task 4.12 Provide Health Services. To preserve, promote, improve, conserve, and restore the mental and physical well being of the force and other designated populations. This task includes providing emergency and routine health care to all personnel; advising commanders on the state of health, sanitation and medical readiness of deploying forces on a continual basis; maintaining health and dental records; keeping a current mass casualty plan; training personnel in basic and advanced first aid; maintaining medical intelligence information files; implementing preventive medicine measures; and ensuring combat readiness of health care personnel assigned to various wartime platforms through continuous training. (JPs 3-02, 3-02.13-07.3, 4-0, 4-02-series, 5-00.2; Naval Doctrine Publication [NDP] 4; Navy Warfare Publication [NWP] 4-02-series; MCWP 4-11.1)

(2) NTA 4.12.1 Perform Triage. To classify incoming casualties by level of treatment required. (JPs 4-0, 4-02-series; NDP 4; NWP 4-02-series; MCWP 4-11.1; FMFM 4-50)

(3) NTA 4.12.2 Provide Ambulatory Health Care. To provide routine, acute, and emergent health services to individuals. (JPs 4-0, 4-02-series; NDP 4; NWP 4-02-series; MCWP 4-11.1)

(4) NTA 4.12.3 Provide Surgical and Inpatient Care. To provide resuscitative and surgical care and inpatient services. (JPs 4-0, 4-02-series; NDP 4; NWP 4-02-series; MCWP 4-11.1)

(5) NTA 4.12.4 Provide Dental Care. To provide routine, acute, and emergent dental services and care to individuals and provide advice and assistance to commanders as required. (JPs 4-0, 4-02-series; NDP 4; NWP 4-02-series; MCWP 4-11.1)

(6) NTA 4.12.5 Coordinate Patient Movement. To coordinate the evacuation of the sick and wounded and to obtain consultation and assistance from remote sources. (JPs 4-0, 4-02-series; NDP 4; NWP 4-02-series; MCWP 4-11.1)

(7) NTA 4.12.6 Provide Industrial and Environmental Health Services. To implement and monitor occupational and environmental hazard abatement measures. Task includes HAZMAT management, storage, and disposal. (JPs 4-0, 4-02-series; NDP 4; NWP 4-02-series; MCWP 4-11-1)

(8) NTA 4.12.7 Maintain Records. To maintain health and dental records, and other documentation relating to the provision of health care. (JPs 4-0, 4-02-series; NDP 4; NWP 4-02-series; MCWP 4-11.1)

(9) NTA 4.12.8 Obtain and Analyze Medical Information. To review, catalog, and report information obtained in the course of current operations to include communicable diseases, epidemiological data, chemical and biological agents, and other useful information. (JPs 4-0, 4-02-series; NDP 4; NWP 4-02-series; MCWP 4-11.1)

(10) NTA 4.12.9 Train Medical and Nonmedical Personnel. To provide training in first aid, preventive medicine and in advanced skills to support medical response to mass casualty situations and operation specific threats. (JPs 4-0, 4-02-series; CJCSI 3500.01; NDP 4; NWP 4-02-series; MCWP 4-11.1)

(11) NTA 4.12.11 Provide Medical Staff Support. To advise the commander on matters relating to the state of health, sanitation, and medical readiness. (JPs 3-0, 4-0, 4-02-series; NDP 4; NWP 4-02-series; MCWP 4-11.1)

(12) NTA 4.12.12 Perform Level II/III Medical Support. To provide and support large scale and Level III medical care for forces ashore (to include hospital [T-AH class] ships and embarked fleet surgical teams in amphibious shipping). (JPs 1, 3-0, 4-0, 4-02; NDP 4; NWP 4-02-series; MCWP 4-11.1)

#### **4. United States Marine Corps Tasks List**

a. The USMC has a standardized, doctrinally based HSS tasks list required in a CBRN environment.

b. The USMC tasks pertaining to HSS in a CBRN environment are as follows:

(1) Marine Corps Task (MCT) 6.4 Operate in a CBRNE Environment. To integrate CBRNE and NBC defense measures designed to detect, defeat, and minimize the effects of CBRNE or NBC attacks. Units occupying bases in the joint rear area must plan and train to perform their missions in a CBRNE or NBC environment, if necessary. The three fundamentals of CBRNE and NBC defense are contamination avoidance, protection, and decontamination. To ensure the detection, warning, and reporting of and protection against

NBC threats in the operational area. (JPs 3-0, 3-10.1 [superseded by 3-10]; MCRPs 3-37A, 3-37B, 3-37.1A, 3-37.2B, 3-37.2C)

(2) MCT 6.4.1 Conduct CBRNE Operations. To plan operations or to operate in an area where an adversary has the capability of employing CBRNE weapons or toxic industrial materials (TIMs) may be encountered which produce effects similar to a CBRNE weapon. The force plans, trains and prepares to conduct mission operations while preventing the adversary from employing CBRNE weapons. If prevention fails, the force uses networked detection systems to locate the hazard, take necessary protective actions, and decontaminate as necessary. Activities such as post-hostility remediation, preparing equipment for redeployment and final disposal in situ or removal of an adversary's residual CBRNE weapon capability are also included. (MCRPs 3-37A, 3-37B, 3-37.1A, 3-37.1B, 3-37.1C, 3-37.2A, 3-37.2B, 3-37.2C; MCWP 3-37, 3-37.1, 3-37.2, 3-37.3, 3-37.4, 3-37.5; UJTL-Chairman of the Joint Chiefs of Staff Manual [CJCSM] 3500.04C)

(3) MCT 6.4.2 Conduct CBRNE Initial Incident Response Operations. The CBIRF was established by direction of the Commandant of the Marine Corps as a result of Presidential Decision Directive 39 (PDD-39), to conduct operations managing the consequences of CBRNE materials or weapons use by terrorists. The CBIRF unit has state-of-the-art monitoring and detection equipment for identifying, sampling and analyzing NBC hazards, including TIM. It is self-contained, self-sufficient and rapidly deployable providing force protection and/or mitigation in the event of WMD incidents. The CBIRF is prepared to no-notice WMD incidents with a rapidly deployable Initial Response Force (IRF) and a follow-on force if required. (MCRPs 3-37A, 3-37B, 3-37.1A, 3-37.1B, 3-37.1C, 3-37.2A, 3-37.2B, 3-37.2C; MCWPs 3-37, 3-37.1, 3-37.2, 3-37.3, 3-37.4, 3-37.5; FM 3-11 [FM 3-100]; NWP 3-11-series; AFTTP [I] 3-2.42)

(4) MCT 6.4.3 Conduct Chemical, Biological, Radiological, and Toxic Industrial Chemical Agent Detection, Identification, Monitoring and Sampling Operations. To conduct detection, identification, monitoring and sampling operations of TIM, particularly TIC and TIB material, and/or TIR material. These chemicals could interfere significantly across the range of military operations. The TIC is corrosive and can damage eyes, skin, respiratory tract, and equipment. Release of TIC is most dangerous at night because typical nighttime weather conditions produce high concentrations that remain close to the ground for extended distances. Once a TIC situation has occurred, detection efforts conducted by CBIRF to determine the extent and duration of residual hazards and decontamination and contamination containment actions need to be implemented. To obtain information by visual observation, or other detection methods, about the activities and resources of an enemy or about the meteorologic, hydrographic, or geographic characteristics of a particular area. To detect and identify NBC hazards including finding gaps and detours around NBC-contaminated areas. NBC reconnaissance, which provides the information for identifying NBC hazards, is part of the overall intelligence collection effort. (JPs 1, 3-0, 3-02, 3-03, 3-01.4 [superseded by 3-01], 3-11, 3-13, 3-15, 3-51 [superseded by 3-13.1]; MCRPs 3-37A, 3-37B, 3-37.1A, 3-37.1B, 3-37.1C, 3-37.2A, 3-37.2B, 3-37.2C; MCWPs 3-37, 3-37.1, 3-37.2, 3-37.3, 3-37.4, 3-37.5; FMFM 13; FM 3-11.4 [FM 3-4]; NDP 1, 4; NWP 3-series; NTTP 3-11-series; AFTTP [I] 3-2.46)

(5) MCT 6.4.4 Conduct CBRNE Reconnaissance and Decontamination Operations. Marine Corps unit capabilities are based on unit equipment and training in NBC detection, protection, reconnaissance and decontamination operations. Marine Corps units have organic NBC personnel and equipment within each organization, down to the battalion and squadron levels. The NBC personnel-intensive tasks (such as NBC reconnaissance operations) are performed by additional duty Marines from within the unit. The Marine

Corps uses the same NBC defense equipment as other Services. The NBC reconnaissance teams can detect and locate most NBC hazards and provide unit commanders with information about where contamination may or may not be present. Collected surveys and data are forwarded to higher headquarters via communications nets (for example, radio, digital nets, and the JWARN). Decontamination tasks include absorbing, destroying, neutralizing, making harmless, or removing chemical or biological agents, or by removing radioactive material clinging to or around a person, object, or area. (JPs 1, 3-0, 3-02, 3-03, 3-01, 3-11, 3-13, 3-15, 3-51 [superseded by 3-13.1]; MCRPs 3-37A, 3-37B, 3-37.1A, 3-37.1B, 3-37.1C, 3-37.2A, 3-37.2B, 3-37.2C; MCWPs 3-37, 3-37.1, 3-37.2, 3-37.3, 3-37.4, 3-37.5; FMFM 13; FM 3-11.4 [FM 3-4]; NDP 1, 4; NWP 3-series; NTTTP 3-11.27; AFTTP [I] 3-2.46)

(6) MCT 6.4.5 Conduct Enhanced NBC Operations. To conduct enhanced defensive and protective operations in an environment in which there is deliberate or accidental use of NBC weapons or agents. Protective measures are taken to keep NBC hazards from having an adverse effect on personnel, equipment, or critical assets and facilities. To obtain information by visual observation, or other detection methods, about the activities and resources of an enemy or about the meteorological, hydrographic, or geographic characteristics of a particular area. To detect and identify NBC hazards including finding gaps and detours around NBC-contaminated areas. NBC reconnaissance, which provides the information for identifying NBC hazards, is part of the overall intelligence collection effort. To take measures to avoid or minimize NBC attacks and reduce the effects of NBC hazards. By taking measures to avoid the effects of NBC attacks, units can reduce their protective postures and decrease the likelihood and extent of decontamination required. (JPs 1, 3-0, 3-02, 3-03, 3-01, 3-11, 3-13, 3-15, 3-51 [superseded by 3-13.1]; MCRPs 3-37A, 3-37B, 3-37.1A, 3-37.1B, 3-37.1C, 3-37.2A, 3-37.2B, 3-37.2C; MCWPs 3-37, 3-37.1, 3-37.2, 3-37.3, 3-37.4, 3-37.5; FMFM 13; FM 3-11 [FM 3-100]; NDP 1, 4; NWP 3-series; NTTTP 3-11-series; AFTTP [I] 3-2.42)

(7) MCT 6.4.6 Provide NBC Defense. To provide the methods, plans, and procedures involved in establishing and exercising defensive measures against the effects of an attack by NBC weapons or radiological warfare agents. It encompasses both the training for, and the implementation of these methods, plans and procedures, and ensures the detection, warning, and reporting of and protection against NBC threats in the operational area. (JPs 1, 3-0, 3-02, 3-03, 3-01, 3-11, 3-13, 3-15, 3-13.1; MCRPs 3-37A, 3-37B, 3-37.1A, 3-37.1B, 3-37.1C, 3-37.2A, 3-37.2B, 3-37.2C; MCWPs 3-17, 3-37, 3-37.1, 3-37.2, 3-37.3, 3-37.4, 3-37.5; FM 3-11 [FM 3-100]; NDP 1, 4; NWP 3-series; NTTTP 3-11.27; AFTTP [I] 3-2.46)

**This page intentionally left blank.**

## Appendix D

# SERVICE-SPECIFIC CHEMICAL, BIOLOGICAL, RADIOLOGICAL, AND NUCLEAR DEFENSE CAPABILITIES

### 1. Service-Specific CBRN Defense Capabilities Descriptions

This appendix contains brief descriptions of Service-specific CBRN defense capabilities (not all-inclusive).

### 2. United States Army Chemical, Biological, Radiological, and Nuclear Defense Capabilities

#### a. United States Army Special Medical Augmentation Response Team.

(1) The SMARTs provide a rapidly available asset to compliment the need to cover the full spectrum of military medical response locally, nationally, and internationally. These teams are organized by the USAMEDCOM and its subordinate commands; they are not intended to supplant TOE units assigned to FORSCOM or other Army commands.

(2) The USAMEDCOM, regional medical commands (RMCs), USACHPPM, USAMRMC, and US Army Veterinary Command (USAVETCOM) commanders organize SMART using their TDA assets. These teams enable the commander to field standardized modules in each of the SMART functional areas to meet the requirements of the mission.

(3) The SMARTs are currently undergoing transformation and are being restructured to meet USAMEDCOM mission requirements. The current approved types of SMARTs include—

- Emergency Medical Response (SMART-EMR).
- Chemical/Biological/Radiological/Nuclear (SMART-CBRN).
- Stress Management (SMART-SM).
- Medical Command, Control, Communications, and Telemedicine (SMART-MC3T).
- Pastoral Care (SMART-PC).
- Preventive Medicine (SMART-PM).
- Burn (SMART-B).
- Veterinary (SMART-V).
- Health Systems Assessment and Assistance (SMART-HS).
- Aeromedical Isolation (SMART-AI).
- Logistics (SMART-LOG).
- Smallpox Emergency Response (SMART-SER).
- Smallpox Specialized Treatment (SMART-SST).
- Investigational New Drug (SMART-IND).
- Radiological Advisory Medical Team (RAMT).

(4) These teams provide military support to civil authorities during disasters, civil-military operations (CMO), and humanitarian and emergency services incidents occurring in the US, its territories and possessions, and OCONUS unified command AORs.

(5) The SMART will be standardized and formalized within the TDA assets of the USAMEDCOM and its subordinate commands.

(6) Requests for assistance may be generated from any governmental organization. These sources may include—

- Department of Homeland Security.
- Department of Health and Human Services.
- United States Northern Command.
- United States Joint Forces Command.
- Federal Emergency Management Agency and local civil agencies.
- Environmental Protection Agency.

(7) Imminently serious conditions resulting from any civil emergency or attack may require immediate response by military commanders. All USAMEDCOM tasking are sent through the Assistant Chief of Staff, Operations (G3).

(8) The USAMEDCOM determines the composition of each team and identifies the specialty specific equipment required to accomplish the mission. The composition of the team is task-organized based on the METT-TC and medical risk analysis in order to provide the appropriate level of response and technical augmentation to civil and military authorities. This information is provided to its subordinate commands through appropriate command policy statements, directives, or the SOP. These teams may be comprised of active duty military, DOD civilians, or contractors, as determined by the commander.

(9) Within 12 hours of notification, the SMART will be alerted, issued a warning order (WARNORD), and assembled; within 12 hours of the WARNORD the SMART will be capable of deploying. The SMART are not capable of 24-hour continuous operations. To conduct continuous operations the deployed SMART require augmentation/reinforcement of both personnel and materiel or support from follow-on medical specialty personnel.

b. Preventive Medicine Services.

(1) On the operational environment, PVNTMED services will be in greater demand than at any other time, especially under BW conditions. Preventive medicine personnel will be called upon to assist the commander in determining the health hazards associated with nuclear fallout; the safety of drinking water in a CBRN environment; as well as determining when to use prophylaxis, pretreatments, immunizations, and other PMM associated with CBRN warfare. Preventive medicine personnel must be aware of the health threat in the AO. They must continually update their medical and OEH surveillance activities to identify disease trends (endemic and epidemic), potential disease vectors, and the susceptibility of troops to these diseases.

(2) Under CBRN conditions, diseases may manifest that exist in the area, but were not being transmitted to personnel. However, due to the reduced health status of personnel from exposures to or from stress-related CBRN conditions, the troops begin to suffer their effects. The appearances of diseases or arthropods not known to exist in the AO are indicators that BW agents have been used. The PVNTMED section of medical brigades and MEDCOMs receive supporting laboratory BW samples/specimen reports. They analyze, consolidate, and report finding to support their headquarters, subordinate commands, and adjacent commands. They ensure that chain of custody protocols are maintained by medical laboratory personnel. For details on PVNTMED operations, see FM 4-02.17.

c. Preventive Medicine Section.

(1) The PVNTMED sections of the medical companies perform analysis on water sources and supplies to determine the presence or absence of CBRN/TIM contamination. Based upon their findings, the water is released for consumption or is restricted from use



until it is treated (usually by water production personnel using the reverse osmosis water purification unit. They also collect arthropods, water, and ice samples for suspect BW agent contamination for supporting medical laboratory analysis. See FM 4-02.12 and FM 4-02.17 for more information on the AML. They monitor, analyze, and report medical laboratory findings on CBRN samples/specimens and monitor chain of custody documentation. They conduct medical and OEH surveillance activities. They conduct limited entomological surveys to determine the existence of disease-vectoring arthropods in the AO. They inspect food service facilities to determine the extent, if any, of CBRN contamination. They evaluate the unit's—

- Immunization status.
- Use of prophylaxis for specific diseases (such as antimalarial tablets) (see TM 4-02.33), for nuclear radiation exposure (such as granisetron for nausea and vomiting) (see FM 4-02.283/NTRP 4-02.21/AFMAN 44-161(I)/MCRP 4-11.1B), and for BW agents (such as ciprofloxacin for postexposure chemoprophylaxis for anthrax) (see FM 8-284/NTRP 4-02.23 (NAVMED P-5042)/AFMAN (I) 44-156/MCRP 4-11.1C).
- Use of SNAPP tablets, if warranted.
- Application of personal hygiene and field sanitation procedures (FM 21-10/MCRP 4-11.1D).

(2) Based upon their findings, they provide recommendations for corrective actions to the commanders. They assist in training US Army unit field sanitation teams (FM 4-25.12); however, they are not members of the unit field sanitation team. They conduct medical and OEH surveillance activities for their command (FM 4-02.17).

d. Preventive Medicine Detachment.

The PVNTMED detachment provides PVNTMED services on an area support basis to units within their assigned AO. These services include, but are not limited to—

- Conducting water surveillance including CBRN contamination.
- Collecting water samples suspected of CBRN/TIM contamination for analysis by supporting medical laboratory.
- Performing food service sanitary inspections.
- Conducting medical and OEH surveillance and providing epidemiological consultation.
- Conducting pest (arthropod and rodent) surveys and surveillance.
- Conducting arthropod control operations.
- Conducting occupational and industrial hygiene surveys.
- Advising commanders on the application of PMM.
- Training the supported units' field sanitation teams.

e. The United States Army Medical Research Institute of Chemical Defense. The USAMRICD is actively engaged in support to homeland defense. The Institute stood up a course to prepare international partners to respond effectively to incidents involving WMD, and the Public Health Service included the Medical Management of Chemical and Biological Casualties Course as required training for its Emergency Management Teams (EMATs). The USAMRICD is actively engaged with both the military and the civilian medical and first responder communities in order that they be fully equipped and confident in their ability to medically manage chemical agent incidents.

f. The United States Army Medical Research Institute of Infectious Diseases. The USAMRIID has spearheaded research to develop medical solutions—vaccines, drugs,

diagnostics, and information—to protect Service members and civilians from biological and infectious threats. The USAMRIID's unique capabilities include BSL-3 and -4 laboratories, expertise in the generation of biological aerosols for testing candidate vaccines and therapeutics, and fully-accredited animal research facilities. The USAMRIID works alongside the CDC and the WHO and supports the FBI, Department of Homeland Security, and other agencies in their role as a reference laboratory that sets the standards for identification of biological agents.

g. Area Medical Laboratory. The AML deploys on order worldwide in tailored teams to conduct health threat detection, confirmation and medical surveillance for CBRNE occupational/environmental health and endemic diseases and CM to protect and sustain the health of the force across full spectrum operations. There are currently two AMLs in the US Army inventory; the 1st and 9th AML. For more information on the AML, refer to Chapter VII.

h. The Mortuary Affairs Center. The Mortuary Affairs Center provides expert advice and assistance, in conjunction with the medical and medical examiners' offices, on managing, treating, and handling contaminated casualties.

### **3. United States Marine Corps Chemical, Biological, Radiological, and Nuclear Defense Capabilities**

a. The Chemical Biological Incident Response Force is an organic element of the II Marine expeditionary force (MEF), Marine Forces Command. All requests for support/training must be processed through the chain of command.

b. When directed, the CBIRF forward-deploys and/or responds to a credible threat of a CBRN incident in order to assist local, state, or federal agencies and designated CCDRs in the conduct of CM operations by providing capabilities for agent detection and identification; casualty search, rescue, and personnel decontamination; and emergency medical care and stabilization of contaminated personnel.

c. The CBIRF's mission is lifesaving. They conduct crisis management/rescue and recovery operations in the aftermath of CBRN incidents. The particular emphasis is on turning contaminated victims into clean patients.

d. The CBIRF consists of approximately 450 Marines, Sailors, civilian employees, and contractors. For garrison/training purposes, it is organized into three permanent companies: headquarters and service company and two reaction force companies. For operations, CBIRF will task organize as required. For immediate response, it has two standing task-organized IRFs. If the situation dictates the standing force can be modified to either reduce or expand on the capabilities below.

e. Each IRF maintains the following capabilities:

(1) All Hazard Reconnaissance. These are two-man teams capable of detecting and identifying CW agents, TICs, BW agents, and radiological hazards. These personnel are capable of operating in PPE Levels A, B, C, and D. Standard detection equipment consists of CWA detectors (CAM; M256 kits), multigas meters (Multi-RAE; colorimetric tubes), radiation detectors (AN/VDR-2; AN/PDR-77; DMC 2000S), portable gas chromatograph/mass spectrometer (hazardous air pollutants on site [HAPSITE]), and biological detection systems (Handheld assays [HHA], RAPIDS; Enzyme-Linked Immuno Sorbent Assay), as well as a mobile laboratory platform containing a university grade gas chromatography-mass spectrometry.

(2) Casualty Search and Extraction. The initial teams consist of 40 personnel down range for the specific purpose of locating and extracting victims from a contaminated area. These extractors are qualified in all levels of PPE. Extract teams have M-Gators (all terrain vehicles) with trailers, wheeled stretchers and Sliding Kendrick's Extraction Devices for victim transportation.

(3) Medical. The medical team consists of a physician (emergency or occupational medicine), physician's assistant, independent duty corpsman, and eight additional corpsmen. The medical team initiates treatment in the hot or warm zone (scenario dependent). Members are capable of operating in Level B, C, and D PPE. Treatment continues through decontamination triage to medical stabilization. Each IRF has trauma supplies for approximately 50 critical or 100 moderate-to-minor patients and carries the equivalent of 1,500 Mark I Nerve Agent Antidote Kits.

(4) Decontamination. Fifteen personnel establish a full decontamination line in approximately 10 minutes and establish zone monitoring to ensure zone integrity. All equipment is stored in one 14-ft box truck. When established the full decontamination line can process 65 to 75 nonambulatory, 200 to 225 ambulatory, and 30 to 45 response force per hour.

(5) Technical Rescue. This team is comprised of 14 personnel certified in confined space, collapsed structure, trench, advanced rope, and vehicle rescue. The team can conduct operations in Level B, C, and D.

(6) Explosive Ordnance Disposal. This is a three man team capable of explosive ordnance disposal (EOD) operations in PPE Levels A, B, C, and D. All personnel are trained extensively in rendering safe IEDs with emphasis on chemical and biological IEDs. The team has standard EOD response equipment, as well as a remote ordnance neutralization system robot, a foam mitigation system, and a search and reconnaissance suit-5 (SRS-5) and EOD-8 bomb suit.

(7) Command, Control, Communications, Computers, and Intelligence. Communications equipment and technicians provide continuous secure/nonsecure voice, facsimile (FAX), radio, and data connectivity to the IRF. The communications equipment ranges from individual handheld very-high or ultrahigh frequency radios to mobile satellite terminals. The IRF is supported by a mobile command center and a tactical command center that link the IRF to its home-base operations post and other national and local emergency response organizations.

(8) Logistics. The IRF arrives as a self-sustaining force. All functions of logistics are resident within the IRF. In addition, the support staff has contracting officials that possess the capability to put large support contracts into immediate action. The only resource the IRF requires at the incident site is a water source. The water source can be a fire hydrant, a pumper/tanker truck, or a standing body of water.

f. The first concept of the CBIRF is based on a no-notice response where an attack has been conducted and the first responders are requesting help. Under that concept, CBIRF employs the IRF. The IRF, as described above, is a task-organized 120-man force on two hour alert. A 10 person assessment team can deploy within one hour.

(1) Vehicle/Fixed Wing Option: Within two hour of the alert, IRF can be mounted on 22 commercial vehicles and be ready to deploy by road march. If air deployment is required, it deploys to the aerial port of embarkation (APOE). All vehicles are packed to embarkation specifications, so if C-5 or C-17 aircraft are available, the vehicles simply drive onto the aircraft after joint inspection. If these aircraft are not available, the IRF can palletize

its equipment in one hour. The cargo is then transportable by any commercial or military cargo aircraft. If the cargo is transported on pallets, there must be trucks provided at the APOD to transport the equipment and personnel to the incident site. Under this concept, as soon as the IRF deploys, a second IRF is formed. This can be completed in about 4 hours.

(2) Landing Craft, Air Cushion (LCAC) Option: The 120-man IRF can deploy from its base headquarters in its response vehicles and be prepared for pickup via LCAC within 2 hours of notification. This response force comes with full IRF capabilities, self-sustainment by ground, and can deploy to the incident site regardless of road congestion.

(3) Helicopter Option: Depending on the incident location, a smaller (48 person) CBIRF element may deploy by CH-53, CH-47 or UH60 (Blackhawk) helicopter. The helicopterborne IRF consists of a reduced IRF capability that can be ready to deploy from its base headquarters within 2 hours of notification. This force enables rapid response to greater distances with dedicated helicopter support.

g. The second CBIRF concept is based on forward deploying a task-organized IRF to a pre-designated staging site in response to a credible threat or an approved request for support. Normally these are designated special event homeland security operations. Under this concept, CBIRF task organizes the deploying element for the specific mission.

h. The IRF carries enough PPE to allow for three entries into the contaminated area by all members of the team. In addition, CBIRF maintains additional PPE in warehouses at its base headquarters. Upon deployment of the IRF, the logistics personnel will prepare additional PPE for immediate resupply.

i. The CBIRF is a lifesaving organization and time is crucial. The CBIRF always maintains a 120-man, 22-vehicle IRF, on a two hour alert. If required, the IRF can be reinforced by a second IRF with up to 200 Marines and Sailors within four hours. The CBIRF can provide two full IRFs or one IRF and one mission-tailored force for independent operations.

j. The CBRN control centers will form the hub for all CBRN defense operations. For additional information on USMC CBRN defense capabilities, refer to MCWP 3-37.1.

#### **4. United States Navy Chemical, Biological, Radiological, and Nuclear Defense Capabilities**

a. Naval Medical Research Center. The mission of the NMRC is to defend members of the armed forces against a biological threat; therefore, rapid biological-detection methods are essential for prompt medical intervention and successful mission accomplishment. To provide for such needs, the NMRC (Biological Defense Research Program [BDRP]) has formed a scientific research program for the development of rapid detection and identification methods for BW agents.

b. Biological Defense Research Program. The BDRP has a transportable, biological field laboratory. The field laboratory is comprised primarily of commercially available scientific lab equipment, except for the HHA (tickets). The field laboratory can process approximately 50 samples (4 to 5 samples a day for a period of approximately 2 weeks) before replenishment of supplies is required.

c. United States Navy EOD Unit. The mission of the USN EOD unit is to eliminate hazards from ordnance that jeopardize operations conducted in support of the national military strategy by providing specially trained, combat-ready, highly mobile forces. Navy

EOD units are employed in a variety of operations, across a wide spectrum of warfare areas, in the execution of this mission.

(1) The Navy EOD units' capabilities are structured for a relatively small footprint and rapid response. The EOD units can split into smaller units to respond to multiple EOD incidents/tasks, which are within the capabilities of a smaller force.

(2) Each unit is trained in a variety of mobility and survivability skills enabling it to operate in a variety of environments both afloat and ashore. The EOD units are capable of responding to underwater and surface ordnance and CBRN threats. They can also provide support for diving and demolition, intelligence collection, aircraft and ordnance recovery, range and underwater clearance, riverine operations, Chief of Naval Operations projects, special warfare operations, and other special operations.

d. Forward Deployable Preventive Medical Unit. The FDPMU is designed to assess, prevent, and reduce health threats in support of deployed operating forces. Other missions for the FDPMU include humanitarian assistance, CM, and disaster relief operations. Capabilities can include chemical, biological, and radiological agent detection and identification, as well as toxic environmental chemical detection and identification.

(1) The FDPMUs are capable of deploying within 96 hours, can serve as a joint force asset to provide specialized preventive medicine, and CBRN response services in support of HSS to CCDRs and JTF commanders. Its capabilities are—

- Conducts medical and disease vector surveillance operations.
- Provides endemic, infectious disease assessment.
- Supports first responders with on-site and deep reach back analytical, consultative capabilities.
- Provides rapid detection of chemical, biological, radiological, or environmental hazards to minimize casualty flow.
- Provides realistic CBRE/WMD medical scenario training and exercises.

(2) The FDPMU may be employed as part of a forward deployed "afloat platform." The FDPMU is comprised of a 13-member team with 5 functional detection/analysis components—

- Preventive medicine.
- Disease vector control.
- Microbiology.
- Logistics support.
- Chemical.

## **5. United States Air Force Deployable Teams Related to the Medical Chemical, Biological, Radiological, and Nuclear Defense**

The USAF deploys various teams to provide a comprehensive medical CBRN defense capability at a bed down location in a threat environment. Each team is designated by a UTC that delineates its manpower and equipment set. These are deployed based on the operational requirements. Those UTCs that have a surveillance/assessment capability may support the deployed ASETF, while others with a patient-directed focus, such as the EMDT, primarily support the deployed AF medical unit. Some examples of AF medical UTCs that play a role in the CBRN arena include—

a. Collectively Protected Small Portable Expeditionary Aeromedical Rapid Response. Rapidly mobile, highly clinically capable 12-person medical personnel and equipment

package designed to support 500 personnel for 5 to 7 days. The CPSPEARR team is deployable within 2 hours and can provide—

- Initial disaster medical assessment.
- Public health/preventive medicine.
- Emergency/flight/primary medicine.
- Emergency surgery (general/orthopedic).
- Critical care.
- Patient transport preparation.
- Communication.

b. Medical Chemical, Biological, Radiological, and Nuclear Defense Team. Composed of three persons: one bioenvironmental engineer and two bioenvironmental engineering technicians. Provides increased wing survivability through CBRN surveillance, detection, and abatement. Advises wing emergency operations center on CBRN threats, decontamination options, personnel protective equipment capabilities, and CBRN health risk to deployed personnel. Provides field CBRN detection through the augmentation of the base CBRN defense cell. The MCBRN team may be deployed with the EMEDS medical facility or stand alone, depending on mission needs.

c. Biological Augmentation Team. The BAT is a two-man, rapidly deployable, laboratory team made up of one laboratory officer and one laboratory technician. This team provides presumptive identification of biological agents and pathogens of operational concern. It may be rapidly deployed with the EMEDS medical facility or individually, depending on mission needs. Team members analyze samples and interpret results using advanced microbiological diagnostic capabilities. The BAT diagnostic tools can identify naturally occurring and induced pathogens in clinical samples and other environmental media. The BAT provides a preventative capability and provides diagnostic data to support early warning of pathogen exposures, as well as assessment of extent and type of microbial contamination in various substances (food, air, water, or soil).

d. Infectious Disease Team (UTC FFHA2). The ID team provides expert support for confirmation, containment, and control of infectious conditions. It is composed of one infectious disease physician, one infection control nurse, and one public health technician. The ID team works with PVNTMED teams and TET to prevent, identify, and treat illness associated with biological warfare.

(1) The ID team will need the support of an EMEDS+10/25/AFTH and additional personnel and equipment sets to diagnose and treat infectious patients. Isolation of infected or suspected infected patients will require a separate isolation facility. Large scale contagious/biological outbreaks will require deployment of the Medical Contagious Casualty Management Equipment Package (UTC FFCCM); Medical Hospital Expansion Package-Personnel Increment 1 (UTC FFEW1); Medical Hospital Expansion Package-Equipment (UTC FFEW); and The Medical Critical Care Team (UTC FFCCU) and its equipment package (FFCC1) can be deployed to enhance critical care capability. It provides support personnel and equipment for an additional four critical care beds. Additional critical care capability requires the deployment of UTC FFCCV, Medical 4-Bed ICU Expansion Team, or additional FFCCU teams and equipment.

(2) The ID modules (FFHA2, FFCCM) should not be deployed with any MTF that does not have microbiologic capabilities, unless that capability is available in-theater and the specimens can be shipped there. Tactics, techniques, and procedures regarding the ID team, as well as contagious casualty management, are contained in AFTTP 3-42.22.

Copies can be downloaded from the Air Combat Command Surgeon General's Expeditionary Ground Medical UTC Management Branch (ACC/SGXM) Web site at <https://afkm.wpafb.af.mil/DocTax/Entry.aspx?Filter=MD-SG-00-15> under the UTC "FFHA2 Infectious Disease Team."

e. Preventive and Aerospace Medicine team. The PAM team's mission is to identify, prevent, and monitor DNBI. The PAM team consists of nine personnel broken into three personnel UTCs and supported by two equipment UTCs to provide expertise throughout the spectrum of PVNTMED activities. The increments can be deployed together or in stages. The first (FFPM1) and second (FFPM2) increments provide the initial capability. The third increment (FFPM3) provides expanded capabilities and sustainment for extended operations, when the population at risk is between 3,000 and 6,500, or in support of an EMEDS +10 or +25. The FFPM4 is an equipment-only package that provides portable ADVON equipment and is normally deployed with the FFPM1. The FFPM5 is an equipment-only package that provides infrastructure and additional equipment in support of a stand-alone PAM team.

(1) The PAM Team 1 (FFPM1), also known as the PAM team (ADVON), is composed of one public health officer, one bioenvironmental engineer, one aerospace medicine specialist, and one independent duty medical technician. It deploys with the lead wing ADVON team when supporting an AEF or the Air Expeditionary Wing. The team is designed to travel light and be extremely mobile so it can perform its PVNTMED mission in a timely manner to meet the needs of the entire AEF population at the beddown location. Therefore, the team will require expeditionary combat support, including access to transportation to accomplish its mission successfully.

(2) The PAM Team 2 (FFPM2) which supplements the ADVON team, is made up of one bioenvironmental engineering technician and one public health technician.

(3) The PAM Team 3 (FFPM3) is composed of two bioengineering technicians and one public health technician.

(4) Detailed TTPs for the PAM team are in AFTTP 3-42.23. Copies can be downloaded from the Air Combat Command Surgeon General's Expeditionary Ground Medical UTC Management Branch (ACC/SGXM) Web site at <https://afkm.wpafb.af.mil/DocTax/Entry.aspx?Filter=MD-SG-00-15> under the category "Preventive Medicine."

f. Wartime Medical Decontamination Team. The primary mission of the EMDT is to provide capability to remove or neutralize CBRN agents on wartime casualties immediately prior to being admitted to the MTF. Standardized EMDTs and equipment assemblages can be deployed, assigned, or pre-positioned to support and enable EMEDS MTFs to safely and effectively treat contaminated casualties without contaminating medical personnel, equipment, or facilities. Wartime medical decontamination teams have a secondary mission to provide technical guidance on food decontamination.

g. Theater Epidemiology Team. The TET provides theater-level support to the AF component command surgeon or JTF surgeon. It is collocated with the theater surgeon or appropriate headquarters element. The team provides threat assessments of environmental and occupational factors, evaluates ID risks and disease/DNBI rates from all sources, and recommends interventions to minimize degradation of combat strength. It coordinates with other medical and line force protection teams and with federal and international agencies. It is composed of five individuals: a PVNTMED physician, a public health officer, a public

health technician, a bioenvironmental engineer, and a bioenvironmental engineering technician.

h. Air Force Radiation Assessment Team. The AFRAT provides manpower and equipment for rapid, global response to radiation/nuclear accidents and incidents. It provides subject matter experts to support planning, surveillance, analysis, and assessment to mitigate radiation health and operational risks resulting from radiation/nuclear events. The AFRAT also provides specialized equipment to support field surveillance, monitoring, and analysis. It provides support to commanders and other decisionmakers during contingency planning, response, and postcontingency/recovery operations. The entire complement of AFRAT UTCs responds to major radiation or nuclear events, while the AFRAT component teams are designed to provide tailored support to planning, pre-positioning, operational, or recovery contingency requirements.

(1) The team is subdivided into ten UTCs consisting of four personnel and equipment rapid-response basic teams, three manpower augmentation teams, and three augmentation team equipment packages. The core rapid response basic UTCs consist of a radiation technical consultant team (FFRN1: Medical Radiological/Nuclear Crisis ADVON Team), a radiation field data collection and assessment team (FFRN2: Medical Radiological/Nuclear Surveillance Team), a radioactive material sample analysis laboratory team (FFRN4: Medical Radiological/Nuclear Laboratory Team), and a personnel radiation monitoring team (FFRN6: Medical Radiological/Nuclear Dosimetry Team). The core teams are each augmented by a manpower team and equipment package for extended duration and/or large scale contingency operations. FFRN2 is augmented by FFRN3 (Medical Radiological/Nuclear Surveillance Augmentation Team) and FFRNA (Medical Radiological/Nuclear Surveillance Augmentation Equipment Package). The FFRN4 is augmented by FFRN5 (Medical Radiological/Nuclear Laboratory Augmentation Team) and FFRNB (Medical Radiological/Nuclear Laboratory Augmentation Equipment Package). The FFRN6 is augmented by FFRN7: Radiological/Nuclear Dosimetry Augmentation Team, and the FFRNC: (Medical Radiological/Nuclear Dosimetry Augmentation Equipment).

(2) The division of AFRAT into the basic teams allows for a tailored response to a given incident dependent on type, scope, and available response resources. With these four functionally-distinct teams, the AFRAT can support specific functions or is capable and trained to respond as a combined team to support large scale contingency operations. The four basic team UTCs are designed for rapid response with 72-hour continuous operation with no resupply.

(3) Detailed TTPs for the AFRAT are contained in AFTTP 3-42.34. Copies can be downloaded from the Air Combat Command Surgeon General's Expeditionary Ground Medical UTC Management Branch (ACC/SGXM) Web site at <https://afkm.wpafb.af.mil/DocTax/Entry.aspx?Filter=MD-SG-00-15> under the UTC "FFRN1 Medical Radiological/Nuclear Crisis ADVON Team".

i. Air Force Technical Applications Center (AFTAC). The AFTAC provides postdetonation plume trajectory prediction, meteorological modeling, complete plume analysis/characterization, and leading-edge technology development for monitoring of CB activities.

## 6. Technical Reachback

Technical reachback is the capability to contact technical SMEs when an issue exceeds the on-scene SME's capability. Reachback should be conducted using established unit protocols. Many of the reachback resources listed in Table D-1 have other primary missions



and are not specifically resourced for reachback. Issues may include nonstandard agent decontamination of CBRN and TIM. This information could include persistency, medical effects, and decontamination or protection requirements.

**Table D-1. Technical Reachback Points of Contact**

<b><i>Organization</i></b>	<b><i>Telephone</i></b>
National Response Center, Chemical Terrorism/Chemical Biological Hot Line	1-800-424-8802
Technical Chemical and Biological Assistance Hot Line	1-877-269-4496
Defense Threat Reduction Agency (DTRA)	1-877-244-1187 or 1-703-325-2102
Armed Forces Radiobiology Research Institute (AFRRI)	1-301-295-0316/0530
US Army Center for Health Promotion and Preventive Medicine (USACHPPM)	1-800-222-9698
US Army Medical Research Institute of Infectious Diseases (USAMRIID)	1-888-872-7443
US Army Medical Research Institute of Chemical Defense (USAMRICD)	1-410-322-6822
Centers for Disease Control and Prevention (CDC)	1-770-488-7100

**This page intentionally left blank.**

## REFERENCES

### NATO Standardization Agreements (STANAGs)

All STANAGs can be found at (<http://nsa.nato.int/NSALogin/main.html>)

- STANAG 2002 (Ed 10), *Warning Signs for the Marking of Nuclear, Biological and Chemical Contaminations*, 28 March 2006.
- STANAG 2047 (Ed 7), *Emergency Alarms of Hazard or Attack (NBC and Air Attack Only)*, 24 July 1998.
- STANAG 2068 (Ed 5), *Emergency War Surgery*, 12 September 2005.
- STANAG 2083 (Ed 6), *Commander's Guide on Nuclear Radiation Exposure of Groups During War*, 22 May 2003.
- STANAG 2103 (Ed 9), *Reporting Nuclear Detonations, Biological and Chemical Attacks, and Predicting and Warning of Associated Hazards and Hazard Areas (Operator's Manual)—ATP-45(C)*, 1 December 2005.
- STANAG 2104 (Ed 9), *Friendly Nuclear Strike Warning (STRIKWARN)*, 20 May 2003.
- STANAG 2112 (Ed 5), *Nuclear, Biological and Chemical Reconnaissance*, 12 September 2005.
- STANAG 2132 (Ed 2), *Documentation Relative to Medical Evacuation, Treatment, and Causes of Death of Patients*, 7 August 1974.
- STANAG 2228 (Ed 2), *Allied Joint Medical Support Doctrine—AJP-4.10(A)*, 3 March 2006.
- STANAG 2348 (Ed 3), *Basic Military Hospital (Clinical) Records*, 10 March 1998.
- STANAG 2462 (Ed 1), *NATO Handbook on the Medical Aspects of NBC Defensive Operations (Biological)—AMedP-6(C), Volume II*, 11 May 2005.
- STANAG 2475 (Ed 1), *Planning Guide for the Estimation of NBC Battle Casualties (Nuclear)—AMedP-8(A), Volume I*, 25 April 2002.
- STANAG 2476 (Ed 2), *Medical Planning Guide of NBC Battle Casualties (Biological)—AMedP-8(B) Volume II*, 20 December 2007.
- STANAG 2477 (Ed 1), *Planning Guide for the Estimation of NBC Battle Casualties (Chemical)—AMedP-8(A), Volume III*, 25 April 2002.
- STANAG 2478 (Ed 1), *Medical Support Planning for Nuclear, Biological and Chemical Environments*, 10 February 2006.
- STANAG 2827 (Ed 5), *Materials Handling in the Field*, 18 May 2005.
- STANAG 2873 (Ed 4), *Concept of Operations of Medical Support in Chemical, Biological, Radiological, and Nuclear Environments—AMedP-7(D)*, 6 December 2007.
- STANAG 2879 (Ed 3), *Principles of Medical Policy in the Management of a Mass Casualty Situation*, 7 September 1998.
- STANAG 2885 (Ed 4), *Emergency Supply of Water in War*, 18 February 2004.
- STANAG 2931 (Ed 2), *Orders for the Camouflage of the Red Cross and Red Crescent on Land in Tactical Operations*, 19 January 1998.
- STANAG 2941 (Ed 2), *Guidelines for Air and Ground Personnel Using Fixed and Transportable Collective Protection Facilities on Land*, 19 June 1992.
- STANAG 2954 (Ed 2), *Training of Medical Personnel for NBC Defence Operations*, 12 May 2006.

## **ABCA Quadripartite Standardization Agreements (QSTAGs)**

All QSTAGs can be found at <http://abca-armies.org>.

QSTAG 187 (Ed 1), *Armies Policies and Countries Legislation with Respect to Hazards to Personnel and the Environment*, 29 May 1999.

QSTAG 189, *Quality Policies and Procedures*, 12 August 1991.

QSTAG 470 (Ed 1), *Documentation Relative to Medical Evacuation, Treatment and Cause of Death of Patients*, 23 February 1979.

QSTAG 501 (Ed 2), *Warning Signs for the Marking of Contaminated or Dangerous Land Areas, Complete Equipment, Supplies and Stores*, 11 May 1982.

QSTAG 608 (Ed 3), *Interoperable Chemical Agent Detector Kits*, 13 December 2000.

## **United States Code**

All United States Codes can be found at *United States Code*  
(<http://www.gpoaccess.gov/uscode/index.html>)

10 United States Code, Armed Forces.

32 United States Code, National Guard.

## **Department of Defense**

*Department of Defense publications can be found at*  
<http://www.dtic.mil/whs/directives/index.html> *and Department of Defense forms can*  
*be found at* <http://www.dtic.mil/whs/directives/infomgt/forms/formsprogram.htm>.

Defense Planning Guidance FY 2002-2007, 6 April 2000.

Defense Reform Initiative Directive #25: *DOD Plan for Integration of the National Guard and Reserve Component into Domestic Weapons of Mass Destruction Terrorism Response*, 26 January 1998.

DODD 1404.10, *Emergency-Essential (E-E) DOD U.S. Citizen Civilian Employee*, 10 April 1992.

DODD 2000.12, *DOD Antiterrorism (AT) Program*, 18 August 2003.

DODD 3000.05, *Military Support for Stability, Security, Transition, and Reconstruction (SSTR) Operations*, 28 November 2005.

DODD 3150.8, *DOD Response to Radiological Accidents*, 13 June 1996.

DODD 6400.04, *DOD Veterinary Services Program*, 22 August 2003.

DODD 6490.02E, *Comprehensive Health Surveillance*, 21 October 2004.

DODI 1336.5, *Automated Extract of Active Duty Military Personnel Records*, 2 May 2001.

DODI 2000.16, *DOD Antiterrorism (AT) Standards*, 2 October 2006.

DODI 2000.18, *Department of Defense Installation Chemical, Biological, Radiological, Nuclear and High-Yield Explosive Emergency Response Guidelines*, 4 December 2002.

DODI 3020.37, *Continuation of Essential DOD Contractor Services During Crises*, 6 November 1990.

DODI 4150.07, *DOD Pest Management Program*, 29 May 2008.

DODI 5200.8, *Security of DOD Installations and Resources*, 10 December 2005.

DODI 6055.1, *DOD Safety and Occupational Health (SOH) Program*, 19 August 1998.

DODI 6200.02, *Application of Food and Drug Administration (FDA) Rules to Department of Defense Force Health Protection Programs*, 27 February 2008.  
DODI 6490.03, *Deployment Health*, 11 August 2006.  
DD Form 1380, *U.S. Field Medical Card*.  
DD Form 2064, *Certificate of Death (Overseas)*.  
DD Form 2697, *Report of Medical Assessment*.  
DD Form 2766, *Adult Preventive and Chronic Care Flowsheet*.  
DD Form 2795, *Pre-Deployment Health Assessment*.  
DD Form 2796, *Post-Deployment Health Assessment (PDHA)*.  
DD Form 2900, *Post-Deployment Health Re-assessment (PDHRA)*.  
MIL-STD-3006A, *Sanitation Requirements for Food Establishments*, 7 June 2002. (This publication can be obtained from the Document Automation and Production Service, 700 Robbins Avenue, Bldg. 4, Philadelphia, PA 19111-5094.)  
*Quadrennial Defense Review Report*, 6 February 2006.

*Chairman of the Joint Chiefs of Staff (CJCS) and Memorandum for the Chairman (MCM) publications can be located at [http://www.dtic.mil/cjcs\\_directives/index.htm](http://www.dtic.mil/cjcs_directives/index.htm).*

CJCS Contingency Plan 0500-98, *Military Assistance to Domestic Consequence Management Operations in Response to a Chemical, Biological, Radiological, Nuclear or High-Yield Explosive Situation*, 11 February 2002.  
CJCSIC 3214.01C, *Military Support to Foreign Consequence Management Operations, for Chemical, Biological, Radiological, and Nuclear Incidents*, 11 January 2008.  
MCM 0026-02, *Chemical Warfare (CW) Agent Exposure Planning Guidance*, 26 April 2002.  
MCM 0028-07, *Procedures for Deployment Health Surveillance*, 2 November 2007.

## **Joint Publications**

JP 1-02, *Department of Defense Dictionary of Military and Associated Terms*, 12 April 2001.  
JP 2-01.3, *Joint Tactics, Techniques, and Procedures for Joint Intelligence Preparation of the Battlespace*, 24 May 2000.  
JP 3-0, *Joint Operations*, 17 September 2006.  
JP 3-11, *Operations in Chemical, Biological, Radiological, and Nuclear (CBRN) Environments*, 26 August 2008.  
JP 4-0, *Joint Logistics*, 18 July 2008.  
JP 4-02, *Health Service Support*, 31 October 2006.  
JP 4-06, *Mortuary Affairs in Joint Operations*, 5 June 2006.  
JP 4-08, *Joint Doctrine for Logistic Support of Multinational Operations*, 25 September 2002.  
JP 5-0, *Joint Operation Planning*, 26 December 2006.  
JP 6-0, *Joint Communications System*, 20 March 2006.  
*Joint Concepts of Operations for the Joint Biological Agent Identification and Diagnostic System (JBAIDS)*, Version 2.2, 17 February 2006.  
(<http://www.dcss.cs.amedd.army.mil/JBAIDS/JBAIDS1.htm>)

## Multiservice

- AR 40-562/BUMEDINST 6230.15A/AFJI 48-110/CG COMDTINST M6230.4F, *Immunizations and Chemoprophylaxis*, 29 September 2006.
- AR 40-656/NAVSUPINST 4355.10A/MCO 10110.48, *Veterinary Surveillance Inspection of Subsistence*, 28 August 2006.
- AR 40-657/NAVSUP 4355.4H/MCO P10110.31H, *Veterinary/Medical Food Safety, Quality Assurance, and Laboratory Service*, 21 January 2005.
- FM 1-02/MCRP 5-12A, *Operational Terms and Graphics*, 21 September 2004.
- FM 3-11/MCWP 3-37.1/NWP 3-11/AFTTP (I) 3-2.42, *Multiservice Tactics, Techniques, and Procedures for Nuclear, Biological, and Chemical Defense Operations*, 10 March 2003.
- FM 3-11.3/MCRP 3-37.2A/NTTP 3-11.25/AFTTP(I) 3-2.56, *Multiservice Tactics, Techniques, and Procedures for Chemical, Biological, Radiological, and Nuclear Contamination Avoidance*, 2 February 2006.
- FM 3-11.4/MCWP 3-37.2/NTTP 3-11.27/AFTTP (I) 3-2.46, *Multiservice, Tactics, Techniques, and Procedures for Nuclear, Biological, and Chemical (NBC) Protection*, 2 June 2003.
- FM 3-11.5/MCWP 3-37.3/NTTP 3-11.26/AFTTP(I) 3-2.60, *Multiservice Tactics, Techniques, and Procedures for Chemical, Biological, Radiological, and Nuclear Decontamination*, 4 April 2006.
- FM 3-11.9/MCRP 3-37.1B/NTRP 3-11.32/AFTTP(I) 3-2.55, *Potential Military Chemical/Biological Agents and Compounds*, 10 January 2005.
- FM 3-11.14/MCRP 3-37.1A/NTTP 3-11.28/AFTTP(I) 3-2.54, *Multiservice Tactics, Techniques, and Procedures for Nuclear, Biological, and Chemical Vulnerability Assessment*, 28 December 2004.
- FM 3-11.19/MCWP 3-37.4/3-11.29/AFTTP(I) 3-2.44, *Multiservice Tactics, Techniques, and Procedures for Nuclear, Biological, and Chemical Reconnaissance*, 30 July 2004.
- FM 3-11.21/MCRP 3-37.2C/NTTP 3-11.24/AFTTP (I) 3-2.37, *Multiservice Tactics, Techniques, and Procedures for Chemical, Biological, Radiological, and Nuclear Consequence Management Operations*, 1 April 2008.
- FM 3-11.34/MCWP 3-37.5/NTTP 3-11.23/AFTTP(I) 3-2.33, *Multiservice Tactics, Techniques, and Procedures for Installation CBRN Defense*, 6 November 2007.
- FM 3-11.86/MCWP 3.37.1C/NTTP 3-11.31/AFTTP(I) 3-2.52, *Multiservice Tactics, Techniques, and Procedures for Biological Surveillance*, 4 October 2004.
- FM 4-02.283/NTRP 4-02.21/AFMAN 44-161(I)/MCRP 4-11.1B, *Treatment of Nuclear and Radiological Casualties*, 20 December 2001.
- FM 4-02.285 (FM 8-285)/MCRP 4-11.1A/NTRP 4-02.22/AFTTP (I) 3-2.69, *Multiservice Tactics, Techniques, and Procedures for Treatment of Chemical Agent Casualties and Conventional Military Chemical Injuries*, 18 September 2007.
- FM 4-25.11/NTRP 4-02.1.1/AFMAN 44-163(I)/MCRP 3-02G, *First Aid*, 23 December 2002.
- FM 6-22.5, *Combat and Operational Stress Control Manual for Leaders and Soldiers*, 18 March 2009.
- FM 8-284/NTRP 4-02.23 (NAVMED P-5042)/AFMAN (I) 44-156/MCRP 4-11.1C, *Treatment of Biological Warfare Agent Casualties*, 17 July 2000.
- FM 21-10/MCRP 4-11.1D, *Field Hygiene and Sanitation*, 21 June 2000.
- FM 90-3/FMFM 7-27, *Desert Operations*, 24 August 1993.

- TB MED 507/AFPAM 48-152(I), *Heat Stress Control and Heat Casualty Management*, 7 March 2003.
- TB MED 577/NAVMED P-5010-9/AFOSH Standard 48-7, *Sanitary Control and Surveillance of Field Water Supplies*, 15 December 2005.  
([https://akocomm.us.army.mil/usapa/med/DR\\_pubs/dr\\_a/pdf/tbmed577.pdf](https://akocomm.us.army.mil/usapa/med/DR_pubs/dr_a/pdf/tbmed577.pdf))
- TM 3-4240-288-12&P/NAVFAC P-475, *Operator's and Unit Maintenance Manual Including Repair Parts and Special Tools List for Collective Protection Equipment Nuclear, Biological, and Chemical, Simplified, M20 (NSN 4240-01-166-2254)*, 20 August 1987.
- TM 3-6665-331-10/TO 11H2-20-1, *Operator's Manual for Chemical Agent Monitor (CAM)*, 12 June 1992.
- TM 9-4120-4111-14/TO 35E9-314-1, *Operator, Unit, Direct and Ground Support for Air conditioner 66,000 BTU/HR, 208/230 Volt Three-Phase 50/60 Hertz Model FDECU-2*, 17 October 2008.

## Army

*Department of the Army publications and forms can be found at <http://www.apd.army.mil>.*

- AR 40-5, *Preventive Medicine*, 25 May 2007.
- AR 40-13, *Medical Support—Nuclear/Chemical Accidents and Incidents*, 1 February 1985.
- AR 40-61, *Medical Logistics Policies*, 28 January 2005.
- AR 40-66, *Medical Record Administration and Healthcare Documentation*, 17 June 2008.
- AR 40-400, *Patient Administration*, 6 February 2008.
- DA Form 2028, *Recommended Changes to Publications and Blank Forms*
- DA Form 4137, *Evidence/Property Custody Document*.
- FM 3-06, *Urban Operations*, 26 October 2006.
- FM 3-06.11, *Combined Arms Operations in Urban Terrain*, 28 February 2002.
- FM 3-11.20, *Technical Escort Battalion Operations*, 29 August 2007.
- FM 3-11.22, *Weapons of Mass Destruction—Civil Support Team Operations*, 10 December 2007.
- FM 3-34, *Engineer Operations*, 2 April 2009.
- FM 4-02, *Force Health Protection in a Global Environment*, 13 February 2003.
- FM 4-02.1, *Combat Health Logistics*, 28 September 2001.
- FM 4-02.2, *Medical Evacuation*, 8 May 2007.
- FM 4-02.4, *Medical Platoon Leaders' Handbook—Tactics, Techniques, and Procedures*, 24 August 2001.
- FM 4-02.6, *The Medical Company—Tactics, Techniques, and Procedures*, 1 August 2002.
- FM 4-02.10, *Theater Hospitalization*, 3 January 2005.
- FM 4-02.12, *Health Service Support in Corps and Echelons Above Corps*, 2 February 2004.
- FM 4-02.17, *Preventive Medicine Services*, 28 August 2000.
- FM 4-02.18, *Veterinary Service—Tactics, Techniques, and Procedures*, 30 December 2004.
- FM 4-02.19, *Dental Service Support Operations*, 31 July 2009.
- FM 4-02.25, *Employment of Forward Surgical Teams Tactics, Techniques, and Procedures*, 28 March 2003.

FM 4-02.51, *Combat and Operational Stress Control*, 6 June 2006.  
 FM 4-20.64, *Mortuary Affairs Operations*, 9 January 2007.  
 FM 4-25.12, *Unit Field Sanitation Team*, 25 January 2002.  
 FM 3-34.400 (FM 5-104), *General Engineering*, 9 December 2008.  
 FM 5-19, *Composite Risk Management*, 21 August 2006.  
 FM 6-22.5 (FM 22-51), *Combat and Operational Stress Control Manual for Leaders and Soldiers*, 18 March 2009.  
 FM 7-15, *The Army Universal Task List*, 27 February 2009.  
 FM 8-50, *Prevention and Medical Management of Laser Injuries*, 8 August 1990.  
 FM 8-55, *Planning for Health Service Support*, 9 September 1994.  
 FM 8-250, *Preventive Medicine Specialist*, 27 January 1986.  
 FM 10-52, *Water Supply in Theaters of Operations*, 11 July 1990.  
 FM 31-71, *Northern Operations*, 21 June 1971.  
 FM 90-5, *Jungle Operations*, 16 August 1982.  
 FMI 4-02.46, *Medical Support to Detainee Operations*, 8 November 2007.  
*Medical Command Pamphlet 525-1, Medical Emergency Management Planning*, 1 October 2003.  
 TB MED 502, *Occupational and Environmental Health Respiratory Protection Program (DLAM 1000.2)*, 15 February 1982.  
 TB MED 577, *Sanitary Control and Surveillance of Field Water Supplies*, 15 December 2005.  
 TM 3-4240-300-10-2, *Operator's Manual for Chemical-Biological Mask: Combat Vehicle, M42 (NSN 4240-01-258-0064) Small, (4240-01-258-0065) Medium, (4240-01-258-0066) Large*, 30 August 1988.  
 TM 3-4240-312-12&P, *Operator's and Unit Maintenance Manual for Mask, Chemical-Biological: Aircraft, M43, Type I (NSN 4240-01-208-6966) Small, (4240-01-208-6967) Medium, (4240-01-208-6968) Large, (4240-01-208-6969) Extra Large; Type II (4240-01-265-2677) Small; (4240-01-265-2679) Medium; (4240-01-265-2678) Large; (4240-01-265-2680) Extra Large*, 30 June 1988.  
 TM 3-6665-307-10, *Operator's Manual for Chemical Agent Detector Kit: M256 (NSN 6665-01-016-8399) and M256A1 (6665-01-133-4964)*, 1 September 1985.  
 TM 3-6665-311-10, *Operator's Manual for Paper, Chemical Agent Detector: M9 (NSN 6665-01-226-5589)*, 31 August 1998.  
 TM 4-02.33 (FM 4-02.33), *Control of Communicable Diseases Manual*, 19th Edition, 1 June 2009.  
 TM 10-5410-283-14&P, *Operator's, Unit, Direct Support, and General Support Maintenance Manual (Including Repair Parts and Special Tools List) Chemically Protected Deployable Medical System (CPDEPMEDS) (NSN 5410-01-479-9730) (5410-01-479-9727) and CPDEPMEDS Training Set (6910-01-479-2464)*, 30 November 2001.  
 TM 10-5410-228-10, *Operator's Manual for Chemical Biological Protective Shelter (CBPS) System (NSN 5410-01-441-8054) (Green); (5410-01-482-4633) (Tan)*, 19 March 2004.  
 TM 11-6665-251-10, *Operator's Manual for Radiac Set AN/VDR-2 (NSN 6665-01-222-1425)*, 1 March 1988.  
 US Army Soldier and Biological Chemical Command (SBCCOM), *Guidelines for Cold Weather Mass Decontamination During a Terrorist Chemical Agent Incident*, January 2002, Revision 1, August 2003.



Note: USACHPPM Technical Guides are located at  
<http://usachppm.amedd.army.mil/tg.htm>.

- USACHPPM TG 188, *US Army Food and Water Vulnerability Assessment Guide*, July 2008.
- USACHPPM TG 195, *Mortuary Affairs: Infectious Materials and CBRN Handling*, May 2009.
- USACHPPM TG 230, *Chemical Exposure Guidelines for Deployed Military Personnel*. (Version 1.3—Updated May 2003 with January 2004 Addendum.)
- USACHPPM, TG 244, *The Medical NBC Battlebook*, August 2002.
- USACHPPM TG 273, *Diagnosis and Treatment of Diseases of Tactical Importance to U.S. Central Command*, October 2005.
- USACHPPM, *Deployment Health Guide: Toxic Industrial Chemicals (TIC) Release Response*. (<http://chppm-www.apgea.army.mil/documents/Disaster/TICResponse2.pdf>)
- USACHPPM, *Hazardous and Toxic Industrial Chemicals Tables*, October 2007. (<http://chppm-www.apgea.army.mil/chemicalagent/PDFFiles/TICResponseCharts.pdf>)
- USACHPPM, *Chlorine Improvised Explosive Devices and Preventive Medicine Actions*. ([http://usachppm.apgea.army.mil/documents/FACT/36-015-0407\\_Chlorine\\_IEDs.pdf](http://usachppm.apgea.army.mil/documents/FACT/36-015-0407_Chlorine_IEDs.pdf))
- USACHPPM, *Best Practice Guidelines for CBR Mass Personnel Decontamination*, Second Edition, 2004, Technical Support Working Group (TSWG), National Interagency Research and Development Program CBRN Subgroup. (Hard copies can be obtained by contacting: [cbrncsubgroup@TSWG.gov](mailto:cbrncsubgroup@TSWG.gov))
- USAMRICD, *Medical Management of Chemical Casualties Handbook*, Sixth Edition, December 2008.
- USAMRIID, *Air Evacuation under High-Level Biosafety Containment: The Aeromedical Isolation Team*, 1999. (USAMRIID, ATTN: MCMR-UIZ-T, 1425 Porter Street, Fort Detrick, MD, 21702-5011.)
- USAMRIID, *USAMRIID's Medical Management of Biological Casualties Handbook*, Sixth Edition, April 2005. (<http://www.usamriid.army.mil/education/instruct.htm>)

## Marine Corps

- MCO 3900.15, *Marine Corps Expeditionary Force Development System (EFDS)*, 26 November 2002. (<http://www.marines.mil/news/publications/Pages/default.aspx>)
- MCO 3500.27B, *Operational Risk Management (ORM)*, 5 May 2004. (<http://www.marines.mil/news/publications/Pages/default.aspx>)

## Navy

Navy Publications and forms can be found at <https://www.nko.navy.mil>.

- NAVMED P-5010-9, *Manual of Preventive Medicine, Chapter 9, Preventive Medicine for Ground Forces*, June 1991 (<http://www-nmcphc.med.navy.mil/downloads/prevmmed/P-5010-9.pdf>).
- NAVSUP P-409, *Military Standard Requisitioning and Issue Procedures (MILSTRIP) and Military Standard Transaction Reporting and Accounting Procedures (MILSTRAP) Desk Guide*, 9 May 2003.
- NTTP 3-20.31, *Surface Ship Survivability* (NSN 0411-LP-102-7654), October 2004.

NTTP 3-20.31.470, *Naval Ships Technical Manual, Chapter 470, Shipboard Biological Warfare/Chemical Warfare Defense and Countermeasures*, Rev.004, 1 November 2006.  
OPNAV 5580/22, *Evidence/Property Custody Receipt*.  
OPNAVINST 5090.1, *Environmental and Natural Resources Program Manual*. 1 November 1994.  
(<http://www.spawar.navy.mil/fleet/insurv/navosh/50901bc2/50901.zip>)  
Tactical Memorandum (TACMEMO) 3-11.1-02, *Guide to Biological Warfare Defense and Bioterrorism—Afloat and Ashore*, 23 October 2002.

## Air Force

AFDD 1-1, *Leadership and Force Development*, 18 February 2006.  
AFDD 2, *Operations and Organization*, 3 April 2007.  
AFDD 2-1.8, *Counter-Chemical, Biological, Radiological, and Nuclear Operations*, 26 January 2007.  
AFI 33-360, *Publications and Forms Management*, 18 May 2006.  
AFMAN 32-4004, *Emergency Response Operations*, 1 December 1995.  
AFMAN 32-4013, *Hazardous Material Emergency Planning and Response Guide*, 1 August 1997.  
AFTTP 3-42.3, *Health Service Support in Nuclear, Biological, and Chemical Environments*, 26 August 2002.  
AFTTP 3-42.5, *Aeromedical Evacuations (AE)*, 1 November 2003.  
AFTTP 3-42.22, *Contagious Casualty Management*, 7 May 2007.  
(<https://kx.afms.mil/doctrine>).  
AFTTP 3-42.23, *Preventive and Aerospace Medicine (PAM) Teams*, 22 February 2006.  
([https://kx.afms.mil/kxweb/dotmil/file/web/ctb\\_071336.pdf](https://kx.afms.mil/kxweb/dotmil/file/web/ctb_071336.pdf))  
AFTTP 3-42.32, *Home Station Medical Response to Chemical, Biological, Radiological, Nuclear, or High Yield Explosive (CBRNE) Events*, 20 April 2004.  
AFTTP 3-42.33, *Expeditionary Medical Decontamination Team*,  
(<https://kx.afms.mil/doctrine>).  
AFTTP 3-42.71, *Expeditionary Medical Support (EMEDS)*, 27 July 2006,  
(<https://kx.afms.mil/doctrine>).

## Other Sources

AFRRI, *Medical Management of Radiological Casualties Handbook*, Second Edition, April 2003. (<http://www.afri.usuhs.mil/outreach/pdf/2edmmrhandbook.pdf>)  
Borden Institute, *The Textbooks of Military Medicine, Medical Aspects of Chemical and Biological Warfare*, 1997.  
([http://www.bordeninstitute.army.mil/published\\_volumes/chemBio/chembio.html](http://www.bordeninstitute.army.mil/published_volumes/chemBio/chembio.html))  
Department of Health and Human Services (DHHS), CDC, NIOSH Publication No. 2005-149, *NIOSH Pocket Guide to Chemical Hazards*, September 2005. (Third Printing—September 2007, with minor technical changes.) (<http://www.cdc.gov/niosh/npg/>)  
Department of Health and Human Services CDC-731, *International Certificate of Vaccination* (Rev 2007). (Stock Number: 017-001-00567-3, ISBN: 9780160795879).  
Department of Homeland Security, National Incident Management System, 1 March 2004. (<http://www.dhs.gov/xlibrary/assets/NIMS-90-web.pdf>)  
Department of Homeland Security, *National Response Framework*, 22 January 2008.  
(<http://www.dhs.gov/journal/leadership/2008/01/national-response-framework.html>)

Department of Transportation, *Emergency Response Guidebook* (A Guidebook for First Responders During the Initial Phase of a Dangerous Goods/Hazardous Materials Transportation Incident), 2008. This guidebook can be obtained at <http://hazmat.dot.gov/pubs/erg/guidebook.htm>.

*Emergency War Surgery*, Third United States Revision, 2004. ([http://www.bordeninstitute.army.mil/other\\_pub/ews.html](http://www.bordeninstitute.army.mil/other_pub/ews.html))

Giesbrecht, G.G. *Prehospital treatment of hypothermia*, Wilderness and Environmental Medicine, Volume 12, pp 24-31 (2001).

Homeland Security Presidential Directive-5 (HSPD-5), *Management of Domestic Incidents*, 28 February 2003. ([http://www.dhs.gov/xabout/laws/gc\\_1214592333605.shtm](http://www.dhs.gov/xabout/laws/gc_1214592333605.shtm))

OSHA Regulation (Standards—29 CFR), *Hazardous Waste Operations and Emergency Response—1910.120*. ([www.osha.gov](http://www.osha.gov))

Pilch, Fran, *The Worried Well: Strategies for Installation Commanders*. Colorado Springs: U.S. Air Force Academy, Institute for National Security Studies (INSS), 2004. (<http://www.usafa.af.mil/df/inss/occasion.cfm>)

Presidential Decision Directive 39, *U.S. Policy on Counterterrorism (U)*, 21 June 1995. (<http://www.fas.org/irp/offdocs/pdd39.htm>)

Public Law (PL) 107-296, *Homeland Security Act of 2002*, 25 November 2002. ([http://www.dhs.gov/xlibrary/assets/hr\\_5005\\_enr.pdf](http://www.dhs.gov/xlibrary/assets/hr_5005_enr.pdf))

*Robert T. Stafford Disaster Relief and Emergency Assistance Act (Stafford Act) (Public Law 100-707)*; The Stafford Act is a 1988 amended version of the Disaster Relief Act of 1974 (Public Law 93-288), June 2007. (<http://www.fema.gov/about/stafact.shtm>)

*Unified Command Plan for Fiscal Year 2000* (Revised 1 October 2002).

## Web sites

Air Force Publications (<https://kx.afms.mil/doctrine>)

Air Force Institute for Operational Health. (<http://www.brooks.af.mil/units/airforceinstituteforoperationalhealth/index.asp>)

Armed Forces Health Surveillance Center (<http://afhsc.army.mil>)

Army Publications (<http://www.apd.army.mil>)

ACC SG-Manpower & Equipment Force Packaging (MEFPAK) (<https://afkm.wpafb.af.mil/DocTax/Entry.aspx?Filter=MD-SG-00-15>)

Deployment Health Clinical Center (DHCC) (<http://www.pdhealth.mil>)

DOD Directives (<http://www.dtic.mil/whs/directives/corres/dir.html>)

DOD Instructions (<http://www.dtic.mil/whs/directives/corres/ins1.html>)

Forms (<http://www.dtic.mil/whs/directives/infomgt/forms/formsprogram.htm>)

Joint Publications (<http://www.dtic.mil/doctrine/jpreferencepubs.htm>)

Marine Corps Publications (<https://www.doctrine.usmc.mil>)

Military Standards (<http://www.everyspec.com/MIL-STD/>)

Navy Publications (<https://www.nko.navy.mil>)

NATO Standardization Agreements (STANAGS) (<http://nsa.nato.int/NSALogin/main.html>)

U.S. Army Center for Health Promotion and Preventative Medicine (<http://chppm-www.apgea.army.mil/>)

United States Code (<http://www.gpoaccess.gov/uscode/index.html>)

**This page intentionally left blank.**

# GLOSSARY

## PART I—ABBREVIATIONS AND ACRONYMS

### A

<b>A2S</b>	Army Medical Department Shelter System
<b>AAR</b>	after action report
<b>ABCA</b>	American, British, Canadian, and Australian Armies Program
<b>ABO</b>	agents of biological origin
<b>ABS</b>	airbeam assembly
<b>AC</b>	hydrogen cyanide (also called hydrocyanic acid)
<b>ACADA</b>	automatic chemical agent detector alarm
<b>ACAT</b>	acquisition category
<b>ACU</b>	Army combat uniform
<b>ADVON</b>	advance echelon
<b>AE</b>	aeromedical evacuation
<b>AECM</b>	aeromedical evacuation crew member
<b>AEF</b>	air and space expeditionary force
<b>AELT</b>	aeromedical evacuation liaison team
<b>AESMT</b>	aeromedical evacuation stage management team
<b>AFB</b>	Air Force base
<b>AFDD</b>	Air Force doctrine document
<b>AFFOR</b>	Air Force forces
<b>AFHSC</b>	Armed Forces Health Surveillance Center
<b>AFI</b>	Air Force instruction
<b>AFJI</b>	Air Force joint instruction
<b>AFMAN (I)</b>	Air Force manual (interservice)
<b>AFME</b>	Armed Forces Medical Examiner
<b>AFMS</b>	Air Force Medical Service
<b>AFPAM</b>	Air Force pamphlet
<b>AFRAT</b>	Air Force Radiation Assessment Team
<b>AFRRI</b>	Armed Forces Radiobiology Research Institute
<b>AFT</b>	Air Force task
<b>AFTAC</b>	Air Force Technical Applications Center
<b>AFTH</b>	Air Force Theater Hospital
<b>AFTTP (I)</b>	Air Force tactics, techniques, and procedures (interservice)
<b>AIT</b>	aeromedical isolation team
<b>AKO</b>	Army Knowledge Online
<b>amb</b>	ambulance
<b>AMC</b>	Army Materiel Command
<b>AMEDD</b>	Army Medical Department
<b>AMedP</b>	Allied medical publication
<b>AML</b>	area medical laboratory
<b>AO</b>	area of operations
<b>AOR</b>	area of responsibility
<b>APOD</b>	aerial port of debarkation
<b>APOE</b>	aerial port of embarkation
<b>AR</b>	Army regulation

<b>ART</b>	Army tactical task
<b>ASCC</b>	Army service component command
<b>ASETf</b>	air and space expeditionary task force
<b>ATI</b>	aircraft transport isolator
<b>ATM</b>	advanced trauma management
<b>ATNAA</b>	antidote treatment–nerve agent, autoinjector
<b>ATP</b>	Allied tactical publication
<b>ATSO</b>	ability to survive and operate
<b>attn</b>	attention
<b>AUTL</b>	Army universal task list

## **B**

<b>BAL</b>	British anti-Lewisite (dimercaprol)
<b>BAS</b>	battalion aid station
<b>BAT</b>	biological augmentation team
<b>BCT</b>	brigade combat team
<b>BDO</b>	battle dress overgarment
<b>BDRD</b>	Biological Defense Research Directorate
<b>BDRP</b>	Biological Defense Research Program
<b>BDU</b>	battle dress uniform
<b>BEE</b>	bioenvironmental engineering
<b>BH</b>	behavioral health
<b>BICEPS</b>	brevity, immediacy, contact, expectancy, proximity, and simplicity
<b>BSL</b>	biosafety level
<b>BSMC</b>	brigade support medical company
<b>BTA</b>	biological threat agent
<b>BUMEDINST</b>	Bureau of Medicine and Surgery instruction
<b>BW</b>	biological warfare
<b>BZ</b>	3-quinuclidinyl benzilate

## **C**

<b>C</b>	centigrade
<b>C2</b>	command and control
<b>C4I</b>	command, control, communications, computers, and intelligence
<b>C4I2</b>	command, control, communications, computers, intelligence, and information
<b>C4ISR</b>	command, control, communications, computers, intelligence, surveillance, and reconnaissance
<b>C4S</b>	command, control, communications, and computer systems
<b>CA</b>	bromobenzyl cyanide
<b>CAM</b>	chemical agent monitor
<b>CANA</b>	convulsant antidote for nerve agent (diazepam)
<b>CASEVAC</b>	casualty evacuation
<b>CASF</b>	contingency aeromedical staging facility
<b>CB</b>	chemical-biological
<b>CBIRF</b>	chemical-biological incident response force
<b>CBPS</b>	chemical biological protective shelter
<b>CBR</b>	chemical, biological, and radiological
<b>CBRD</b>	chemical, biological, and radiological defense

<b>CBRN</b>	chemical, biological, radiological, and nuclear
<b>CBRND</b>	chemical, biological, radiological, and nuclear defense
<b>CBRNE</b>	chemical, biological, radiological, nuclear, and high-yield explosives
<b>CBRNWRS</b>	chemical, biological, radiological, and nuclear warning and reporting system
<b>CCATT</b>	critical care aeromedical transport team
<b>CCDR</b>	combatant commander
<b>CCMRF</b>	chemical, biological, radiological, and nuclear consequence management response force
<b>CCP</b>	casualty collection point
<b>CDC</b>	Centers for Disease Control and Prevention
<b>CE</b>	civil engineering
<b>CERFP</b>	chemical, biological, radiological, nuclear, and high-yield explosives enhanced response force package
<b>cfm</b>	cubic feet per minute
<b>CFR</b>	Code of Federal Regulations
<b>CG</b>	phosgene; Coast Guard
<b>CHRP</b>	contaminated human remains pouch
<b>CIP</b>	command information program
<b>CJCS</b>	Chairman of the Joint Chiefs of Staff
<b>CJCSI</b>	Chairman of the Joint Chiefs of Staff instruction
<b>CK</b>	cyanogen chloride
<b>Cl</b>	chlorine
<b>CLS</b>	combat lifesaver
<b>CM</b>	consequence management
<b>CMO</b>	civil-military operations
<b>CMS</b>	central materiel and supply
<b>CN</b>	chloroacetophenone
<b>CNS</b>	central nervous system
<b>COA</b>	course of action
<b>COMDTINST</b>	Commandant, United States Coast Guard instruction
<b>CONOPS</b>	concept of operations
<b>CONUS</b>	continental United States
<b>COP</b>	common operational picture
<b>COS</b>	combat and operational stress
<b>COSC</b>	combat and operational stress control
<b>COSR</b>	combat and operational stress reaction
<b>CP</b>	command post
<b>CPDEPMEDS</b>	chemically protected deployable medical system
<b>CPE</b>	collective protection equipment
<b>CPEMEDS</b>	collectively protected expeditionary medical support
<b>CPHMEP</b>	collective protection hospital medical expansion package
<b>CPHSEP</b>	collective protection hospital surgical expansion package
<b>CPS</b>	collective protection shelter
<b>CPSPEARR</b>	collectively protected small portable expeditionary aeromedical rapid response
<b>CPSSS</b>	collectively protected small shelter system
<b>CS</b>	o-chlorobenzylidene malononitrile
<b>CSEPP</b>	Chemical Stockpile Emergency Preparedness Program
<b>CSH</b>	combat support hospital
<b>CV</b>	aircraft carrier

**CVN** aircraft carrier, nuclear  
**CW** chemical warfare  
**CX** phosgene oxime

## **D**

**DA** Department of the Army  
**DAD** detailed aircraft decontamination  
**DC** Dental Corps  
**DD** Department of Defense (official forms only)  
**DE** directed-energy  
**decon** decontamination  
**DED** detailed equipment decontamination  
**DEPMEDS** deployable medical systems  
**DFAC** dining facility  
**DHS** Department of Homeland Security  
**DIA** Defense Intelligence Agency  
**DMC** deployed medical commander  
**DMSB** Defense Medical Standardization Board  
**DMSS** Defense Medical Surveillance System  
**DNA** deoxyribonucleic acid  
**DNBI** disease and nonbattle injury  
**DOD** Department of Defense  
**DODD** Department of Defense directive  
**DODI** Department of Defense instruction  
**DOEHS** Defense Occupational and Environmental Health Surveillance  
**DOS** Department of State  
**DOT** Department of Transportation  
**DOW** died of wounds  
**DP** diphosgene  
**DS2** decontamination solution 2  
**DSCA** defense support of civil authorities  
**DSN** Defense Switched Network  
**DTD** detailed troop decontamination  
**DTF** dental treatment facility  
**DTRA** Defense Threat Reduction Agency

## **E**

**EAB** echelons above brigade  
**EAC** echelons above corps  
**ECP** entry control point  
**ECU** environmental control unit  
**ECV** expanded capacity vehicle  
**EDK** equipment decontamination kit  
**EMAT** emergency management team  
**EMDT** expeditionary medical decontamination team  
**EMEDS** expeditionary medical support  
**EMF** expeditionary medical facility  
**EMP** electromagnetic pulse  
**EMT** emergency medical treatment



<b>ENT</b>	ear, nose, and throat
<b>EOD</b>	explosive ordnance disposal
<b>EPA</b>	Environmental Protection Agency
<b>EPW</b>	enemy prisoner of war
<b>ERDEC</b>	Edgewood Research, Development and Engineering Center
<b>evac</b>	evacuation

## F

<b>F</b>	Fahrenheit
<b>FADL</b>	Food Analysis and Diagnostic Laboratory
<b>fax</b>	facsimile
<b>FBI</b>	Federal Bureau of Investigation
<b>FDA</b>	Food and Drug Administration
<b>FDECU</b>	field deployable environmental control unit
<b>FDPMU</b>	forward deployed preventive medicine unit
<b>FEMA</b>	Federal Emergency Management Agency
<b>FFA</b>	fan filter assembly
<b>FFBAT</b>	biological augmentation team
<b>FHP</b>	force health protection
<b>FHPGE</b>	force health protection in a global environment
<b>FHPPP</b>	force health protection prescription products
<b>FM</b>	field manual
<b>FMI</b>	field manual-interim
<b>FMC</b>	United States field medical card
<b>FMFM</b>	Fleet Marine Force manual
<b>FOA</b>	forward operations area
<b>FORSCOM</b>	United States Army Forces Command
<b>FS</b>	sulfur-trioxide chlorosulfonic acid solution
<b>FST</b>	forward surgical team
<b>ft</b>	feet; foot
<b>FY</b>	fiscal year

## G

<b>G-agent</b>	a nerve agent
<b>G-2</b>	Army or Marine Corps component intelligence staff officer (Army division or higher staff, Marine Corps brigade or higher staff)
<b>G-3</b>	Army or Marine Corps component operations staff officer (Army division or higher staff, Marine Corps brigade or higher staff)
<b>G-4</b>	Army or Marine Corps component logistics staff officer (Army division or higher staff, Marine Corps brigade or higher staff); Assistant Chief of Staff for Logistics
<b>G6PD</b>	glucose-6-phosphate dehydrogenase
<b>GA</b>	tabun
<b>GB</b>	sarin
<b>GC</b>	gas chromatography
<b>GD</b>	soman
<b>gen</b>	general
<b>GF</b>	cyclosarin

**GOA** government-owned animal  
**GP** general purpose

## H

**H** vesicant; mustard  
**H&S** heat and serve  
**HAZCHEM** hazardous chemicals  
**HAZMAT** hazardous materials  
**HC** hexachloroethane  
**HD** sulfur mustard  
**HEPA** high efficiency particulate air  
**HHA** handheld assay  
**HIV** human immunodeficiency virus  
**HL** mustard-Lewisite mixture  
**HLDLRT** homeland defense laboratory response team  
**HMMWV** high mobility multipurpose wheeled vehicle  
**HN** nitrogen mustard  
**HPAC** hazard prediction and assessment capability  
**HR/hr** human remains; hour  
**HSL** health service logistics  
**HSLs** health service logistic support  
**HSPD** homeland security Presidential directive  
**HSS** health service support  
**HTH** high test hypochlorite

## I

**IC** incident commander  
**ICAM** improved chemical agent monitor  
**ICU** intensive care unit  
**ICW** intermediate care ward  
**ID** infectious disease  
**ID-ME** immediate treatment, delayed treatment, minimal treatment, expectant treatment (system of triage)  
**IED** improvised explosive device  
**IEDK** individual equipment decontamination kit  
**IMA** installation medical authority  
**IOC** initial operational capability  
**IPE** individual protective equipment  
**IRF** initial response force  
**ISO** International Organization for Standardization  
**IV** intravenous

## J

**J-2** intelligence directorate of a joint staff  
**J-3** operations directorate of a joint staff  
**J-4** logistics directorate of a joint staff  
**JBAIDS** Joint Biological Agent Identification and Diagnostic System  
**JBPDS** Joint Biological Point Detection System  
**JBPO** joint blood program office

<b>JECP</b>	joint expeditionary collective protection
<b>JEM</b>	joint effects model
<b>JFC</b>	joint force commander
<b>JFHQ</b>	joint force headquarters
<b>JFS</b>	joint force surgeon
<b>JIT</b>	just-in-time
<b>JOA</b>	joint operational area
<b>JOEF</b>	joint operational effects federation
<b>JP</b>	joint publication
<b>JSLIST</b>	joint service lightweight integrated suit technology
<b>JSOD</b>	Joint Staff Operations Directorate
<b>JTF</b>	joint task force
<b>JTF-CS</b>	Joint Task Force-Civil Support
<b>JWARN</b>	Joint Warning and Reporting Network

## K

<b>kg</b>	kilogram
<b>km</b>	kilometer
<b>kW</b>	kilowatt

## L

<b>L</b>	Lewisite
<b>lab</b>	laboratory
<b>LCAC</b>	landing craft, air cushion
<b>LCL</b>	liquid control line
<b>LHA</b>	amphibious assault ship (general purpose)
<b>LHD</b>	amphibious assault ship (dock)
<b>LMS</b>	lightweight multipurpose shelter
<b>LRN</b>	Laboratory Response Network
<b>LSD</b>	D-lysergic acid diethylamide

## M

<b>MADCP</b>	mortuary affairs decontamination collection point
<b>maint</b>	maintenance
<b>MASF</b>	mobile aeromedical staging facility
<b>MAT</b>	medical analysis tool
<b>MC</b>	Medical Corps
<b>MCBRN</b>	medical chemical, biological, radiological, and nuclear
<b>MCDM</b>	Medical Chemical Defense Materiel
<b>MCM</b>	memorandum for the chairman
<b>MCO</b>	Marine Corps order
<b>MCRP</b>	Marine Corps reference publication
<b>MCT</b>	Marine Corps task
<b>MCWP</b>	Marine Corps warfighting publication
<b>med</b>	medical
<b>MEF</b>	Marine expeditionary force
<b>MES</b>	medical equipment set
<b>METL</b>	mission-essential task list

<b>METT-TC</b>	mission, enemy, terrain and weather, troops and support available-time available, civil considerations
<b>MF2K</b>	Medical Force 2000
<b>mg</b>	milligrams
<b>MGPTS</b>	Modular General Purpose Tent System
<b>MH</b>	mental health
<b>MHS</b>	military health system
<b>MIL-STD</b>	military standard
<b>MILVAN</b>	military van
<b>min</b>	minutes
<b>ml</b>	milliliter
<b>MOPP</b>	mission-oriented protective posture
<b>mph</b>	miles per hour
<b>MRAT</b>	medical radiobiology advisory team
<b>MRE</b>	meal, ready-to-eat
<b>MRI</b>	Medical Reengineering Initiative
<b>MS</b>	mass spectrometry
<b>MSR</b>	main supply route
<b>MTF</b>	medical treatment facility
<b>MTTP</b>	multiservice tactics, techniques, and procedures
<b>MWD</b>	military working dog

## N

<b>NATO</b>	North Atlantic Treaty Organization
<b>NAVMED</b>	Navy medical
<b>NAVSUP</b>	Naval supplement publication
<b>NBC</b>	nuclear, biological, and chemical (only in legacy terms and documents)
<b>NCMI</b>	National Center for Medical Intelligence
<b>NCO</b>	noncommissioned officer
<b>NCOIC</b>	noncommissioned officer in charge
<b>NDMS</b>	National Disaster Medical System
<b>NDP</b>	naval doctrine publication
<b>NEPMU</b>	Navy environmental and preventive medicine unit
<b>NGB</b>	National Guard Bureau
<b>NIOSH</b>	National Institute for Occupational Safety and Health
<b>NL</b>	no limit
<b>NMCPHC</b>	Navy and Marine Corps Public Health Center
<b>NMRC</b>	Naval Medical Research Center
<b>NORAD</b>	North American Aerospace Defense Command
<b>NP</b>	neuropsychiatric
<b>NPG</b>	National Institute for Occupational Safety and Health Pocket Guide to Chemical Hazards
<b>NRF</b>	National Response Framework
<b>NSN</b>	National Stock Number
<b>NTA</b>	Navy tactical task
<b>NTRP</b>	Navy tactical reference publication

**NTTP** Navy tactics, techniques, and procedures  
**NWP** Navy warfare publication

## O

**OB/GYN** obstetric/gynecology  
**OCONUS** outside the continental United States  
**OEG** operational exposure guide  
**OEH** occupational and environmental health  
**OIC** officer in charge  
**op** operative  
**OPLAN** operation plan  
**OPNAV** Office of the Chief of Naval Operations  
**OPSEC** operations security  
**OPTEMPO** operating tempo  
**OR** operating room  
**OSC** on-scene coordinator  
**OSHA** Occupational Safety and Health Administration  
**OT** occupational therapy

## P

**P&D** potency and dated  
**PA** physician assistant  
**PAM** prevention and aerospace medicine  
**PAO** public affairs officer  
**PAPR** powered air-purifying respirator  
**PCR** polymerase chain reaction  
**PDD** Presidential decision directive  
**PDS** patient decontamination site  
**PE** protective entrance  
**PHEO** public health emergency officer  
**PHS** Public Health Service  
**PIU** patient isolation unit  
**PMI** patient movement item  
**PMM** preventive medicine measure  
**pnt** patient  
**PPE** personal protective equipment  
**PPW** patient protective wrap  
**PS** chloropicrin  
**PTE** potentially traumatizing event  
**PVNTMED** preventive medicine

## Q

**QSTAG** quadripartite standardization agreement (ABCA)  
**qt** quart

## R

<b>R&amp;R</b>	rest and recuperation
<b>RADIAC</b>	radiation, detection, indication, and computation
<b>RAMT</b>	radiological advisory medical team
<b>RC</b>	Reserve Component
<b>RDD</b>	radiological dispersal devices
<b>Rh</b>	Rhesus factor
<b>RMC</b>	regional medical command
<b>ROM</b>	restriction of movement
<b>RSDL</b>	reactive skin decontamination lotion
<b>RSO&amp;I</b>	reception, staging, onward movement, and integration
<b>RTD</b>	return to duty

## S

<b>S-2</b>	intelligence staff officer
<b>S-3</b>	operations staff officer
<b>S-4</b>	logistics staff officer
<b>SARS</b>	severe acute respiratory syndrome
<b>SCBA</b>	self-contained breathing apparatus
<b>SCPE</b>	simplified collective protection equipment
<b>SDDC</b>	Surface Deployment and Distribution Command
<b>SDK</b>	skin decontaminating kit
<b>SecDef</b>	Secretary of Defense
<b>SERPACWA</b>	skin exposure reduction paste against chemical warfare agents
<b>SITREP</b>	situation report
<b>SMART</b>	special medical augmentation response team
<b>SMART-AI</b>	special medical augmentation response team-aeromedical isolation
<b>SMART-B</b>	special medical augmentation response team-burn
<b>SMART-CBRN</b>	special medical augmentation response team-chemical, biological, radiological, and nuclear
<b>SMART-EMR</b>	special medical augmentation response team-emergency medical response
<b>SMART-HS</b>	special medical augmentation response team-health systems assessment and assistance
<b>SMART-IND</b>	special medical augmentation response team-investigational new drug
<b>SMART-LOG</b>	special medical augmentation response team-logistics
<b>SMART-MC3T</b>	special medical augmentation response team-medical command, control, communications, and telemedicine
<b>SMART-PC</b>	special medical augmentation response team-pastoral care
<b>SMART-PM</b>	special medical augmentation response team-preventive medicine/disease surveillance
<b>SMART-SER</b>	special medical augmentation response team-smallpox emergency response
<b>SMART-SM</b>	special medical augmentation response team-stress management
<b>SMART-SST</b>	special medical augmentation response team-smallpox specialized treatment
<b>SMART-V</b>	special medical augmentation response team-veterinary
<b>SME</b>	subject matter expert

<b>SNAPP</b>	soman nerve agent pretreatment pyridostigmine
<b>SOP</b>	standing operating procedure
<b>SPOD</b>	sea port of debarkation
<b>sq ft</b>	square feet
<b>STANAG</b>	Standardization Agreement (NATO)
<b>stat</b>	immediately
<b>STB</b>	super tropical bleach
<b>surg</b>	surgical
<b>svc</b>	service(s)

## T

<b>T-AH</b>	hospital ship
<b>TALP</b>	tunnel airlock litter patient
<b>TAP</b>	toxicological agent protective
<b>TB</b>	tuberculosis
<b>TB MED</b>	technical bulletin, medical
<b>TDA</b>	Table of Distribution and Allowance
<b>TE</b>	technical escort
<b>TEM</b>	traumatic event management
<b>TEMPER</b>	tent, extendable, modular, personnel
<b>TET</b>	theater epidemiology team
<b>TEU</b>	technical escort unit
<b>TG</b>	technical guide
<b>TIB</b>	toxic industrial biological
<b>TIC</b>	toxic industrial chemical
<b>TIH</b>	toxic inhalation hazard
<b>TIM</b>	toxic industrial material
<b>TIR</b>	toxic industrial radiological
<b>TM</b>	technical manual
<b>TO</b>	theater of operations; technical order
<b>TOE</b>	table of organization and equipment
<b>TPFDD</b>	time-phased force and deployment data
<b>TSOP</b>	tactical standing operating procedure
<b>TST</b>	tuberculin skin test
<b>TTP</b>	tactics, techniques, and procedures
<b>2-PAM CI</b>	2-pralidoxime chloride

## U

<b>UCS</b>	unified command suite
<b>UGR</b>	unitized group rations
<b>UJTL</b>	Universal Joint Task List
<b>UNA</b>	unit needs assessment
<b>UNS</b>	universal need statement
<b>US</b>	United States
<b>USACHPPM</b>	United States Army Center for Health Promotion and Preventive Medicine
<b>USACMLS</b>	United States Army Chemical School
<b>USAF</b>	United States Air Force
<b>USAMEDCOM</b>	United States Army Medical Command

<b>USAMEDDC&amp;S</b>	United States Army Medical Department Center and School
<b>USAMRICD</b>	United States Army Medical Research Institute of Chemical Defense
<b>USAMRIID</b>	United States Army Medical Research Institute of Infectious Diseases
<b>USAMRMC</b>	United States Army Medical Research and Materiel Command
<b>USANCA</b>	United States Army Nuclear and Chemical Agency
<b>USARNORTH</b>	United States Army North
<b>USAVETCOM</b>	United States Army Veterinary Command
<b>USCG</b>	United States Coast Guard
<b>USJFCOM</b>	United States Joint Forces Command
<b>USMC</b>	United States Marine Corps
<b>USN</b>	United States Navy
<b>USNORTHCOM</b>	United States Northern Command
<b>USTRANSCOM</b>	United States Transportation Command
<b>UTC</b>	unit type code

## V

<b>VCL</b>	vapor control line
<b>Vet</b>	veterinary
<b>VX</b>	O-ethyl S-(2-diisopropylaminoethyl) methylphosphonothiolate

## W

<b>WARNORD</b>	warning order
<b>WBG</b>	wet bulb globe temperature
<b>WHO</b>	World Health Organization
<b>WMD</b>	weapons of mass destruction
<b>WMD-CST</b>	weapons of mass destruction-civil support team
<b>WP</b>	white phosphorus
<b>WQAS-PM</b>	Water Quality Analysis Set- Preventive Medicine

## PART II—TERMS AND DEFINITIONS

**aeromedical evacuation**—The movement of patients under medical supervision to and between medical treatment facilities by air transportation. Also called AE. (JP 1-02)

**biological threat agent field confirmation identification**—Identification of a suspect biological warfare agent by means of devices/materials/technologies that are based on detecting biological markers using two or more independent biomarker results. (FM 4-02.7)

**biological threat agent definitive identification**—The specific identification of a suspect biological warfare agent as to genus and species, serological type, or toxin. This level of identification is by means of devices/materials/technologies that are based on two or more independent biomarker results and using different methodologies. This level of identification is performed in a nationally recognized reference laboratory with a



broader variety of methodologies available and highly skilled testing personnel, thus providing the highest levels of accuracy. (FM 4-02.7)

**biological threat agent field presumptive identification**—Identification of a suspect biological warfare agent by means of devices/materials/technologies that are based on detecting biological markers (biomarkers) using a single methodology or initial systems, or laboratory analysis employing one screening methodology. (FM 4-02.7)

**biological weapon**—An item of materiel which projects, disperses, or disseminates a biological agent including arthropod vectors. (JP 3-11)

**chemical agent**—A chemical substance which is intended for use in military operations to kill, seriously injure, or incapacitate mainly through its physiological effects. The term excludes riot control agents when used for law enforcement purpose, herbicides, smoke, and flames. (JP 3-11)

**chemical, biological, radiological, and nuclear defense**—Measures taken to minimize or negate the vulnerabilities and/or effects of a chemical, biological, radiological, or nuclear incident. Also called CBRN defense. (JP 3-11)

**chemical warfare**—All aspects of military operations involving the employment of lethal and incapacitating munitions/agents and the warning and protective measures associated with such offensive operations. Since riot control agents and herbicides are not considered to be chemical warfare agents, those two items will be referred to separately or under the broader term “chemical,” which will be used to include all types of chemical munitions/agents collectively. Also called CW. (JP 3-11)

**contamination**—1. The deposit, absorption, or adsorption of radioactive material, or of biological or chemical agents on or by structures, areas, personnel, or objects. 2. (Department of Defense only) Food and/or water made unfit for consumption by humans or animals because of the presence of environmental chemicals, radioactive elements, bacteria or organisms, the byproduct of the growth of bacteria or organisms, the decomposing material (to include the food substance itself), or waste in the food or water. (JP 3-11)

**contamination control**—A combination of preparatory and responsive measures designed to limit the vulnerability of forces to chemical, biological, radiological, nuclear, and toxic industrial hazards and to avoid, contain, control exposure to, and, where possible, neutralize them. (JP 3-11)

**decontamination**—The process of making any person, object, or area safe by absorbing, destroying, neutralizing, making harmless, or removing chemical or

biological agents, or by removing radioactive material clinging to or around it. (JP 3-11)

**immediate decontamination**—Decontamination carried out by individuals immediately upon becoming contaminated to save lives, minimize casualties, and limit the spread of contamination. This may include decontamination of some personal clothing and/or equipment. (JP 3-11)

**individual protective equipment**—In chemical, biological, radiological, or nuclear operations, the personal clothing and equipment required to protect an individual from chemical, biological, and radiological hazards and some nuclear hazards. Also called IPE. (JP 3-11)

**medical evacuation**—Medical evacuation is performed by dedicated, standardized medical evacuation platforms, with medical professionals who provide the timely, efficient movement and en route care of the wounded, injured, or ill persons from the battlefield and/or other locations to medical treatment facilities. Also called MEDEVAC. (FM 4-02.2)

**mission-oriented protective posture**—A flexible system of protection against chemical, biological, radiological, and nuclear decontamination. This posture requires personnel to wear only that protective clothing and equipment (mission-oriented protective posture gear) appropriate to the threat level, work rate imposed by the mission, temperature, and humidity. Also called MOPP. (JP 3-11)

**nuclear warfare**—Warfare involving the employment of nuclear weapons. (JP 1-02)

**operational decontamination**—Decontamination carried out by an individual and/or a unit, restricted to specific parts of operationally essential equipment, materiel and/or working areas, in order to minimize contact and transfer hazards and to sustain operations. This may include decontamination of the individual beyond the scope of immediate decontamination, as well as decontamination of mission-essential spares and limited terrain decontamination. (JP 3-11)

**OSHA Level A**—The greatest level of skin, respiratory, and eye protection is required; encapsulating chemical resistant protective clothing with self-contained breathing apparatus. (OSHA Regulation (Standards-29 CFR))

**OSHA Level B**—The highest level of respiratory protection is necessary but a lesser level of skin protection is needed; nonencapsulating chemical resistant clothing, boots, and gloves with self-contained breathing apparatus type devices. (OSHA Regulation (Standards-29 CFR))

**OSHA Level C**—The concentration(s) and type(s) of airborne substance(s) is known and the criteria for using air purifying respirators are met; nonencapsulating chemical resistant clothing, boots, and gloves with specialized respiratory protection. Respirator either removes particulate matter or gases and vapors from the atmosphere. (OSHA Regulation (Standards-29 CFR)

**patient decontamination**—The removal and/or the neutralization of hazardous levels of chemical, biological, radiological and nuclear contamination from patients at a medical treatment facility. Patient decontamination is performed under the supervision of medical personnel to prevent further injury to the patient and to maintain the patient's health status during the decontamination process. Patient decontamination serves multiple purposes; it protects the patient from further injury, it prevents exposing medical personnel to the contamination, and it prevents contamination of the medical treatment facility. (FM 4-02.7)

**radiological dispersal device**—An improvised assembly or process, other than a nuclear explosive device, designed to disseminate radioactive material in order to cause destruction, damage, or injury. Also called RDD. (JP 3-11)

**thorough decontamination**—Decontamination carried out by a unit, with or without external support, to reduce contamination on personnel, equipment, materiel, and/or working areas equal to natural background or to the lowest possible levels, to permit the partial or total removal of individual protective equipment and to maintain operations with minimum degradation. This may include terrain decontamination beyond the scope of operational decontamination. (JP 3-11)

**toxic industrial biological**—Any biological material manufactured, used, transported, or stored by industrial, medical, or commercial processes which could pose an infectious or toxic threat. Also called TIB. (JP 3-11)

**toxic industrial chemical**—A chemical developed or manufactured for use in industrial operations or research by industry, government, or academia. For example: pesticides, petrochemicals, fertilizers, corrosives, poisons, and so forth. These chemicals are not primarily manufactured for the specific purpose of producing human casualties or rendering equipment, facilities, or areas dangerous for human use. Hydrogen cyanide, cyanogen chloride, phosgene, and chloropicrin and industrial chemicals that also can be military chemical agents. Also called TIC. (JP 3-11)

**toxic industrial material**—A generic term for toxic or radioactive substances in solid, liquid, aerosolized, or gaseous form that may be used, or stored for use, for industrial, commercial, medical, military, or domestic purposes. Toxic industrial material may be chemical, biological, or radioactive and

described as toxic industrial chemical, toxic industrial biological, or toxic industrial radiological. Also called TIM. (JP 3-11)

**toxic industrial radiological**—Any radiological material manufactured, used, transported, or stored by industrial, medical, or commercial processes. For example: spent fuel rods, medical sources, and so forth. Also called TIR. (JP 3-11)

# INDEX

References are to page numbers except where specified otherwise.

## A

aerosols, I-6–7, III-14, III-19, V-2, D-3, D-10  
Air Force Radiation Assessment Team (AFRAT), X-9, D-8, D-10  
aircraft transport isolator (ATI), IV-4–5  
AN/VDR-2, I-8, II-15, V-13, V-21, V-80, VI-21, D-4  
area medical laboratory (AML), VI-6, VII-1, VII-3, VII-6, C-3–4, D-3–4, Glossary-13  
arrival point, V-37, V-39, V-76–77

## B

bacteria, VI-16, Glossary-13–14  
biological augmentation team (FBAT), VII-10  
biosafety level, IV-4  
BZ. *See* 3-quinuclidinyl benzilate.

## C

CASEVAC. *See* casualty evacuation.  
casualty evacuation (CASEVAC), III-9, IV-2  
CG. *See* phosgene.  
chemical-biological incident response force (CBIRF), VII-10, X-7–8, C-10, D-4–6  
chemical biological protective shelter (CBPS), III-11–13, VI-3, XI-2, XI-7–10, XI-18  
chemical, biological, radiological, and nuclear consequence management response force (CCMRF), X-3  
chemical, biological, radiological, and nuclear warning and reporting system (CBRNWRS), II-14  
chemical, biological, radiological, nuclear, and high-yield explosives enhanced response force package (CERFP), X-5  
chloroacetophenone (CN), VI-18  
chloropicrin (PS), I-2, I-6, VI-18  
CK. *See* cyanogen chloride.  
CN. *See* chloroacetophenone.  
cold zone, III-21, V-7, V-14, V-21–22  
collective protection shelter (CPS), II-5, II-7, II-12–13, III-11, III-14–16, III-19, III-22–24, XI-1–4, XI-6, XI-12–13, XI-17–22  
collectively protected expeditionary medical support (CPMEDS), XI-3, XI-5–6, X-9

collectively protected small portable expeditionary aeromedical rapid response (CPSPEAR), XI-5, D-7  
combat and operational stress  
    control (COSC), i, III-11, Chapter VIII, B-2, C-2–4  
    reaction (COSR), V-1, V-45, Chapter VIII  
combat lifesaver (CLS), I-7–8, II-9, III-10, VI-13  
CS. *See* O-chlorobenzylidene malononitrile.  
CX. *See* phosgene oxime.  
cyanogen chloride (CK), I-2, I-6, VI-18–19  
cyclosarin (GF), I-2

## D

D-lysergic acid diethylamide (LSD), I-2  
definitive identification, VII-2–3, VII-6, VII-10–12  
diazepam, I-5, VI-13  
diphosgene (DP), I-2, I-6  
dirty dump, V-15, V-38–39, V-48, V-51, V-53, V-57–59, V-77  
DP. *See* diphosgene.

## E

entry control point (ECP), I-8, III-21, V-9, V-13–14, V-17–18, V-37, V-44, V-76–77  
evacuation corridor, V-7  
expeditionary medical support (EMEDS), II-14, III-2, VII-2, XI-5–6, D-8–9

## F

field  
    confirmatory identification, VII-1, VII-3, VII-6, VII-8, VII-12  
    presumptive identification, VI-21, VII-6, VII-8, X-5, Glossary-13  
force health protection (FHP), i, iii, I-1, I-3, I-15–16, II-1, II-3, II-5–7, II-10, II-13, II-16, III-8, IV-3, IX-1  
forward deployed preventive medicine unit (FDPMU), VII-2, VII-6, X-7, D-7  
FS. *See* sulfur-trioxide chlorosulfonic acid solution.

## G

GA. *See* tabun.  
GB. *See* sarin.  
GD. *See* soman.  
GF. *See* cyclosarin.

## H

HC. *See* hexachloroethane.  
HD. *See* sulfur mustard.  
health threat, I-1, I-3, I-4, I-16, I-18–20, II-1–2, II-6, II-8–10, III-8, VII-1, VII-12, X-7, D-2, D-4, D-7  
hexachloroethane (HC), VI-18  
HL. *See* mustard-Lewisite mixture.  
HN. *See* nitrogen mustard.  
hot line, I-11, III-4, III-11, III-13, III-16, III-21–22, V-9, V-14, V-16, V-18, V-20–22, V-25, V-37–40, V-42, V-44–45, V-47, V-51–53, V-55–59, V-76, V-81–82, XI-8–9  
hot zone, III-21, V-6–7

## I

improvised chemical agent monitor (ICAM), II-15, III-1, III-21, III-26, V-4, V-9, V-13–14, V-21, V-42–44, V-51, V-55–56, V-58, V-61–62, V-69–76, V-80, XI-18, XI-20  
individual protective equipment (IPE), I-10, II-3, II-10, II-12, III-7–8, XI-3–4, XI-6–7, XI-17, C-5, Glossary-14–15  
isolation, I-7, I-10, II-6, III-19, III-28, IV-4–7, VIII-3, D-8  
aeromedical, IV-4, D-1  
zone, V-6

## J

Joint  
Biological Agent Identification and Diagnostic System (JBAIDS), II-5, VII-1, VII-4, VII-6–10, X-8  
Effects Model (JEM), I-21, A-1–2  
expeditionary collective protection (JECF), xvii, XI-6–7  
operational effects federation (JOEF), A-2–3  
Warning and Reporting Network (JWARN), I-21–22, II-12, A-1, A-3, C-11

## L

laboratory response network (LRN), VII-7–8, VII-12  
levels of decontamination, V-2, VI-7  
liquid control line, V-22, Glossary-7  
LSD. *See* D-lysergic acid diethylamide.

## M

medical  
analysis tool (MAT), A-1  
equipment set (MES), II-5, V-35, V-40, IX-3, B-2  
mortuary affairs, III-2–3, V-3, V-20, B-5, C-8, D-4  
mustard-Lewisite mixture (HL), I-2

## N

Navy environmental and preventive medicine unit (NEPMU), VII-9, VII-12  
National Institute for Occupational Safety and Health (NIOSH), I-12, V-8  
nitrogen mustard (HN), VI-17  
nonpersistent agent, III-13, III-17, XI-1

## O

O-chlorobenzylidene malononitrile (CS), VI-18  
O-ethyl S-(2-diisopropylaminoethyl) methylphosphonothiolate (VX), I-2, V-4–5  
Occupational Safety and Health Administration (OSHA), IV-4, V-6, V-8  
Level A, V-7, X-5, Glossary-14  
Level B, V-7, X-5, Glossary-15  
Level C, V-7, V-18–22, V-53, Glossary-15  
operation plan (OPLAN), I-16, I-18, II-10, IX-1–2, B-2, B-4

## P

patient  
isolation unit (PIU), IV-4, IV-6–7  
protective wrap (PPW), II-10, II-12, III-14, III-17–18, III-22–25, IV-3, XI-11, XI-20–21  
persistent agent, III-13, XI-1  
personal protective equipment (PPE), III-7, V-3–4, D-3, X-5, D-4–6  
phosgene (CG), I-2, I-6, VI-18  
phosgene oxime (CX), I-2

phosphoric acid, VI-18  
physostigmine salicylate, VI-15  
polymerase chain reaction (PCR), II-5, VII-1, VII-7,  
VII-11, X-8, Glossary-12  
pralidoxime chloride (2-PAM Cl), VI-12–14  
prevention and aerospace medicine (PAM) Team, VII-2,  
X-9, D-9  
PS. *See* chloropicrin.  
pyridostigmine bromide, II-10

## Q

quarantine, I-7, II-8, II-13, III-19, III-28

## R

radiological dispersal devices (RDD), iii, I-4, III-13,  
Glossary-15  
reactive skin decontamination lotion (RSDL), II-8, V-10,  
V-13, VI-10–12, VI-16–17  
restriction of movement (ROM), III-28

## S

sarin (GB), I-2, II-5, III-29, V-4  
self-contained breathing apparatus (SCBA), I-11–12,  
V-6, Glossary-14  
shuffle pit, III-5, V-21, V-39–40, V-44, V-51–52, V-55,  
V-57–59, V-77, XI-8–9  
sodium  
    bicarbonate, VI-8  
    carbonate, VI-12  
    thiosulfate, VI-19  
soman (GD), I-2, VI-14  
stability operations, I-14–15  
sulfur  
    mustard (HD), I-2, V-5, V-14–17  
    trioxide chlorosulfonic acid solution (FS), VI-18

## T

tabun (GA), I-2  
TEMPER, III-14, III-20, XI-1, XI-3–5, XI-13, XI-17  
theater epidemiology team (TET), VII-2, X-9, D-8–9  
3-quinuclidinyl benzilate (BZ), I-2, VI-14–15

toxic industrial  
    biological (TIB), iii, C-10, Glossary-15  
    chemical (TIC), iii, I-4–5, I-9, I-12–13, I-18–19,  
    II-15, V-4, V-6, V-11, V-13, X-8, C-10, D-4,  
    Glossary-15  
    material (TIM), i, iii, I-1–2, I-4, I-9, I-10–12, I-18,  
    I-21, II-2, II-15–16, III-12, IV-4, V-1, V-6, VII-11,  
    X-5, X-8, XI-6, B-1–2, C-10, D-2–3, D-9–10,  
    Glossary-15  
    radiological (TIR), iii, C-10, Glossary-15–16  
toxin, I-3, I-7, V-4, V-10, V-13, VI-21, VIII-6, X-8,  
    Glossary-13  
triage, II-5, II-10, II-13, III-1, III-4–6, III-9, III-11,  
    III-13–14, III-16, III-21–22, III-24, V-9, V-14–19,  
    V-22–23, V-36–40, V-44–46, V-52–55, V-57, V-66,  
    V-72, V-75–77, V-79, V-81, VIII-1, VIII-6–7, X-5–7,  
    XI-8–9, XI-11, C-5, C-7–8, D-3, D-5  
2-PAM Cl. *See* pralidoxime chloride.

## U

United States Transportation Command  
(USTRANSCOM), II-6, IV-1, IV-4, IV-6, IX-3–4,  
C-4

## V

vapor control line (VCL), V-14, V-22, V-31, V-44,  
V-53, V-55, V-57–59, Glossary-12  
virus, I-19, II-9, IV-8, V-4, VII-5, VII-10, D-7  
VX. *See* O-ethyl S-(2-diisopropylaminoethyl)  
methylphosphonothiolate.

## W

warm zone, III-21, V-6–7, V-14, V-18, V-21–22, D-5  
weapons of mass destruction (WMD), I-13–14, II-10,  
II-12, X-3–4, X-6–7, A-1–2, C-10, D-3, D-7  
    civil support team (WMD-CST), X-3–5, X-8  
worried well, III-28–29, V-1

**This page intentionally left blank.**



**FM 4-02.7  
MCRP 4-11.1F  
NTTP 4-02.7  
AFTTP 3-42.3  
15 July 2009**

**By Order of the Secretary of the Army:**

**GEORGE W. CASEY, JR**  
*General, United States Army*  
*Chief of Staff*

**Official:**



**JOYCE E. MORROW**  
*Administrative Assistant to the*  
*Secretary of the Army*  
0917502

**DISTRIBUTION:**

*Active Army, Army National Guard, and US Army Reserve:* To be distributed in accordance with the initial distribution number (IDN) 114899, requirements for FM 4-02.7.

**By Order of the Secretary of the Air Force**

**THOMAS J. LOFTUS**  
Major General, USAF, MC, CFS  
Assistant Surgeon General  
Health Care Operations  
Office of the Surgeon General

**Marine Corps Distribution: PCN: 144 000168 00**

